

AC-DC Converters

**POWER
SOLVE**

www.powersolve.co.uk

1500 Watts GFR1K5 Series



- 1U Blind-Mate, Hotswap, Redundant
- All Models Share Same Compact Size
- 56 V Power Over Ethernet Compatible Model
- High Power Density 18 W/in³
- Up to 6 kW in 1U (Rack Available)
- AC OK, DC OK, Inhibit, Enable, 5 V Standby
- Current Share & I²C Interface
- -20 °C to +70 °C Operation

Specification

Input

Input Voltage	• 85-264 VAC, see derating curve
Input Frequency	• 47-63 Hz
Input Current	• 13 A/6.5 A typical at 115/230 VAC
Inrush Current	• 35 A maximum at 264 VAC
Power Factor	• >0.9, compliant with EN61000-3-2 class A
Earth Leakage Current	• 1.5 mA max 264 VAC 60Hz
Input Protection	• Fuse internal 20 AT live and neutral

Output

Output Voltage	• See model table
Output Voltage Trim	• Via potentiometer, see model table
Initial Set Accuracy	• ±1% of nominal with 50% load
Minimum Load	• No minimum load required
Line Regulation	• ±0.5% maximum
Load Regulation	• V1: ±0.5%, V2: ±5%
Start Up Delay	• 1 s typical
Over/Undershoot	• 0.5% typical
Transient Response	• 4% deviation, recovery to within 2% in 500 µs for 50-75-50% load change
Ripple & Noise	• 24-56 V models: 1% max pk-pk 12 V models: 2% max pk-pk V Standby: 3% max pk-pk, 20 MHz BW.
Overvoltage Protection	• 115-140% of V1 nominal, recycle input AC to reset
Overtemperature Protection	• Protects the unit against overtemperature. Auto restart
Overcurrent Protection	• 110 - 140% V1, V Standby power limited
Short Circuit Protection	• Continuous, trip and restart (hiccup mode)
Temperature Coefficient	• 0.02%/°C (after 20 minute warm up)
Remote Sense	• Compensates for 0.5V total drop
Current Share	• Share upto 8 units maximum, units share current within 10% of each other at full load.

Notes

1. Contact sales for class B conducted performance.

General

Efficiency	• 90% typical
Isolation	• 3000 (48-56 V: 4000) VAC Input to Output, 1500 VAC Input to Ground, 500 VDC (48-56 V: 1500 VAC) Output to Ground
Switching Frequency	• 70 kHz (PFC), 130 kHz (main converter)
Power Density	• 18 W/in ³
Signals	• AC OK, DC OK, Inhibit, Enable, I ² C (see Signals page 3 & 4)
MTBF	• 470 Khrs to TELECORDIA SR-332, 25 °C

Environmental

Operating Temperature	• -20 °C to +70 °C, derate linearly from +50 °C at 2.5 %/°C to 50% load at +70 °C
Cooling	• Internal variable speed fans load dependant
Operating Humidity	• 95% RH, non-condensing
Storage Temperature	• -40 °C to +85 °C
Operating Altitude	• 3000 m
Shock	• ±3 shocks in each axis (total 18 shocks) 30 g 11 ms (half sine). Compliant with EN60068-2-27.
Vibration	• 2 g 10-500 Hz 10 sweeps. Compliant with EN60068-2-6.

EMC & Safety

Emissions	• EN55022 class A conducted & radiated ⁽¹⁾
Immunity	• Compliant with EN61204-3:2000 high severity levels
Harmonic Currents	• EN61000-3-2 class A
Voltage Flicker	• EN61000-3-3
ESD Immunity	• EN61000-4-2, level 3, Perf Criteria A
Radiated Immunity	• EN61000-4-3, level 3 Perf Criteria A
EFT/Burst	• EN61000-4-4, installation class 3, Perf Criteria A
Surge	• EN61000-4-5, level 3 Perf Criteria A
Conducted Immunity	• EN61000-4-6, level 3, Perf Criteria A
Dips & Interruptions	• EN61000-4-11, 30% 10 ms, 60% 100 ms, 100% 5000 ms, Perf Criteria A, B, B. Semi F47 Compliant.
Safety Approvals	• IEC60950-1:2005 CB Report, CSA-C22.2 No. 60950-1-05, UL60950-1, TUV EN60950-1.

AC-DC Converters

POWER SOLVE

www.powersolve.co.uk

Models and Ratings

GFR1K5

Output Power	Output Voltage V1	Voltage Adj V1	Max Output Current V1		Standby Supply V2	Model Number
			90-264 VAC	> 180 VAC		
1200 W	12.0 VDC	11-14 V	100 A	100 A	5 V/1 A	GFR1K5PS12
1500 W	24.0 VDC	22-28 V	50 A	63 A	5 V/1 A	GFR1K5PS24
1500 W	48.0 VDC	45-52 V	25 A	31 A	5 V/1 A	GFR1K5PS48
1500 W	56.0 VDC	54-59 V	22 A	27 A	5 V/1 A	GFR1K5PS56

Mechanical Details

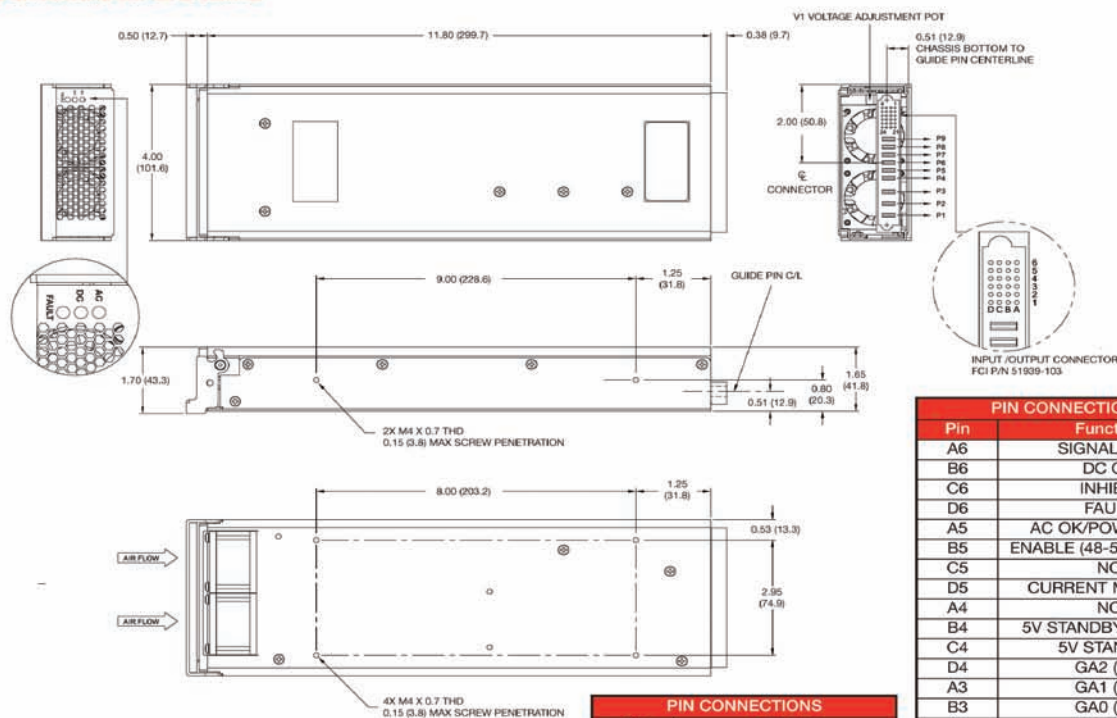

Pin	Function
A6	SIGNAL GND
B6	DC OK
C6	INHIBIT
D6	FAULT
A5	AC OK/POWER FAIL
B5	ENABLE (48-56 V models)
C5	NC
D5	CURRENT MONITOR
A4	NC
B4	5V STANDBY RETURN
C4	5V STANDBY
D4	GA2 (I ² C)
A3	GA1 (I ² C)
B3	GA0 (I ² C)
C3	I ² C GND
D3	PMB SDA (DATALINE)
A2	PMB SCL (CLOCK)
B2	PWR ID
C2	V PROGRAM
D2	ENABLE (12-24 V models)
A1	CURRENT SHARE
B1	NC
C1	- SENSE
D1	+ SENSE

Pin	Function
P1	AC NEUTRAL
P2	AC LINE
P3	CHASSIS GND
P4	-VOUT
P5	-VOUT
P6	-VOUT
P7	+VOUT
P8	+VOUT
P9	+VOUT

Notes

- All dimensions are in inches (mm).
- Weight 5.2 lb (2.35 kg).
- Output connector: BERG/FCI P/N 51939-103LF
Mating connector: BERG/FCI P/N 51866-025LF right-angle PCB receptacle or BERG/FCI P/N 51940-117LF verticle PCB receptacle.

Derating Curves

Input Derating Curve

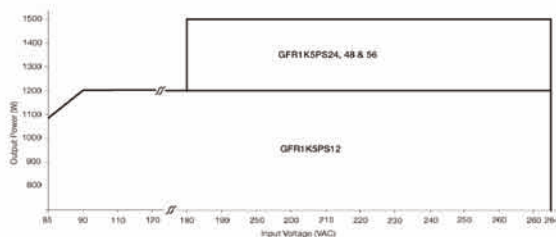

Thermal Derating Curve

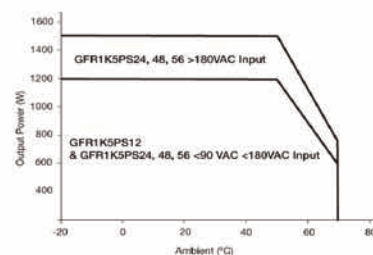

AC-DC Converters

POWER SOLVE

www.powersolve.co.uk

Signals

GFR1K5

AC OK/Power Fail

AC OK is an isolated signal providing a minimum of 5 ms warning of loss of output regulation. The signal is fully isolated and the collector and emitter must be connected externally.

Maximum sink current 2 mA, maximum voltage 20 V.

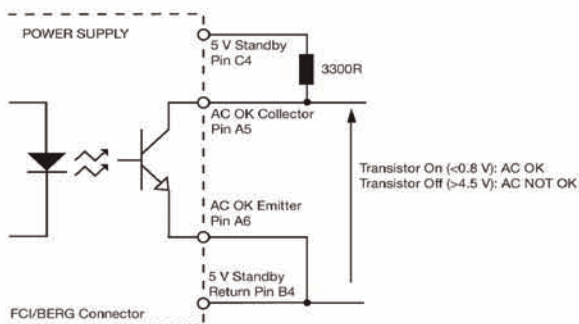

DC OK

DC OK is an isolated signal providing warning that the output voltage has fallen below 90% of nominal. The signal is fully isolated and the collector and emitter must be connected externally.

Maximum sink current 2 mA, maximum voltage 20 V.

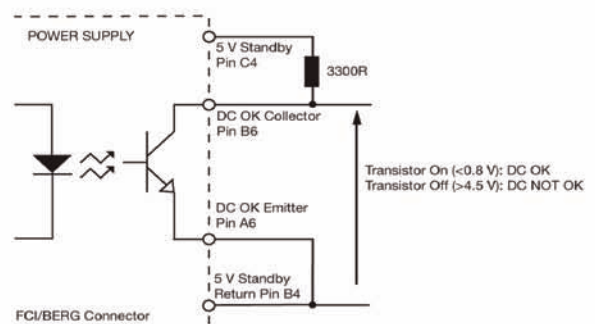

Inhibit

Inhibit is an isolated control signal which can turn the power supply off by supplying 2 to 5mA into the pin.

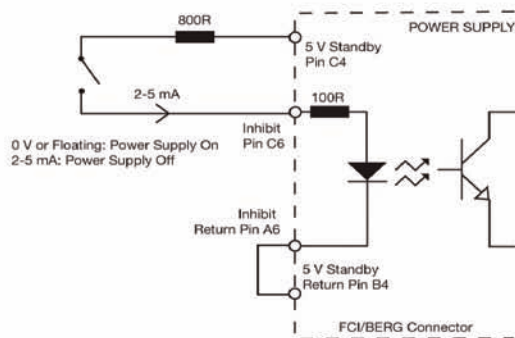

Fault

Fault is an isolated signal providing warning of output voltage below 90% of nominal, fan fault or overtemperature. The signal is fully isolated and the collector and emitter must be connected externally.

Maximum sink current 2 mA, maximum voltage 20 V.

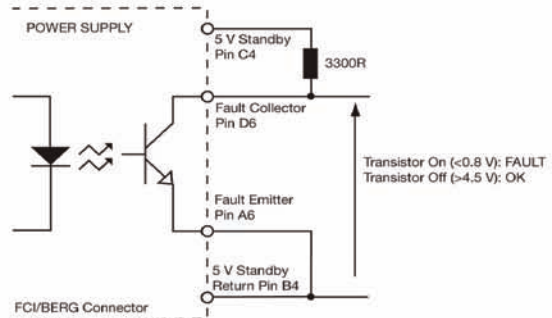

V Program

V Program allows remote voltage adjustment within the range $\pm 10\%$

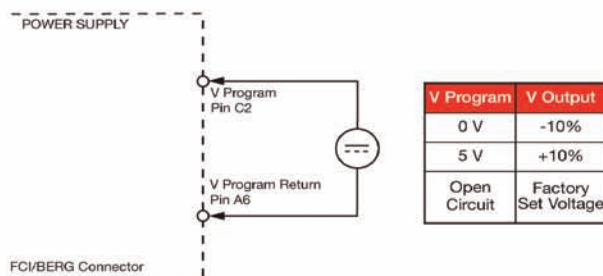

Current Monitor

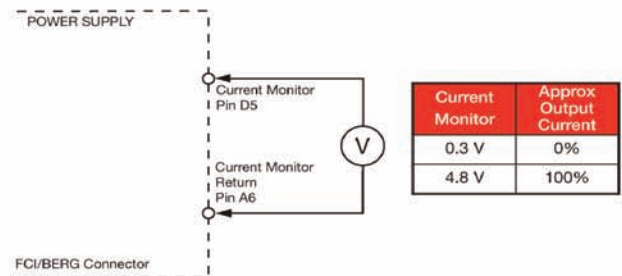

AC-DC Converters

**POWER
SOLVE**

www.powersolve.co.uk

Signals cont.

GFR1K5

Current Share

Connecting pins A1 and C1 of like voltage units (16 maximum) will force the current to share between the outputs. Units share current within 10% of each other at full load. Derate output to 90% of total combined load.

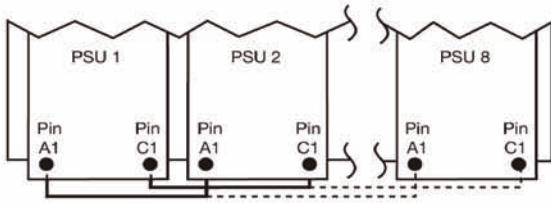

Enable

The enable pin D2 (12-24 V models) or B5 (48-56 V models) is shorter than the other pins and mates last, so that the unit does not power up until the connector is mated correctly connecting pin D2 to -Sense pin C1 thus avoiding connector arcing and premature ageing.

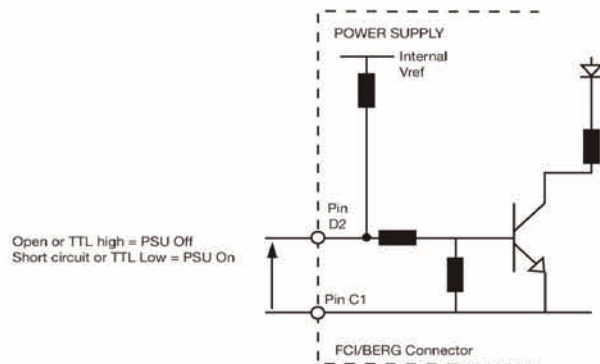

Power ID

The power ID pin B2 can be used to detect the presence of the unit when fitted in a rack.

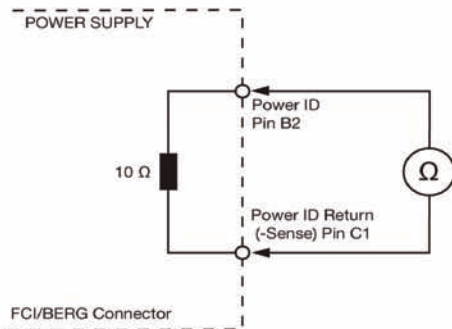

I²C Interface

The I²C PMBus compatible interface can be used for monitoring the output voltage, current, internal temperature and run time. It can also be utilized to turn the unit on and off, detect faults along with identification of the unit model number and serial number.

A separate application note is available detailing the use of this interface, please contact sales for information.



GFR1K5 Rack

A standard 1U 19" Rack is also available which has space for 4 GFR's (6kW) along with I/O connections for power, signals & control. The standard rack is easily customised to suit customer specific requirements.

Consult longform datasheet for full information.