

# UMS100

**600/1200/2400W, DC Power Relay, 30 – 120Vdc, 10 – 320A**

**Intelligent DC Power Switch Relay for Automation & Drives – replaces excessive conventional relay solutions**

**Applications:**

DC Motor drives, breaks, valves, slide feeds, magnet coils, battery bank switching

**Control functions:**

The Camtec Power-Crash-Control circuit protects from short circuits while switching over. The sense polarity is reversed congruent to the outputs.

**Control In-/Outputs:**

Galvanic isolated with photo couplers



## Specification:

- Unlimited operational switches
- Up to 2400W power switching capacity
- Parallel operation N+1 power increase
- Switching current up to 320A
- Switching voltage up to 120Vdc
- Spring-type terminals 25mm<sup>2</sup> / AWG4
- Natural convection DIN-Rail housing
- Interference free EMC behaviour
- Control In-/outputs galvanic isolated
- Left-/right operation mode
- Left-/right control monitor
- Motor STOP! signal optional
- Sense control
- Terminals AWG16-AWG4 (0,5-16mm<sup>2</sup>)
- EMI/EMS EN61000-6-2,3, EN55032 class B
- EN61010-1, EN61010-2-201, EN62368-1



**Technical Data Table**

Power Supply	24Vdc $\pm$ 20% (22-30Vdc/100mA) external industrial level power supply recommended					
Input Rating	typ. 100mA					
Basic Model	UMS00025.10T	UMS00025.15T	UMS00025.20T	UMS00050.20T	UMS00050.30T	UMS00050.40T
Rated Voltage	60V	40V	30V	60V	40V	30V
Rated Current	10A	15A	20A	20A	30A	40A
Boost $\leq$ 10ms	40A	60A	80A	80A	120A	160A
RDSon Tc=25°C	32.9m $\Omega$	12.3m $\Omega$	9.9m $\Omega$	17.1m $\Omega$	6.8m $\Omega$	5.6m $\Omega$
Basic Model	UMS00100.20T	UMS00100.40T	UMS00100.60T	UMS00100.80T		
Rated Voltage	120Vdc	60Vdc	40Vdc	30Vdc		
Rated Current	20A	40A	60A	80A		
Boost $\leq$ 10ms	80A	100A	240A	320A		
RDSon Tc=25°C	26.8m $\Omega$	9.2m $\Omega$	4.1m $\Omega$	3.5m $\Omega$		
Voltage error sequence	Input-/output: +20% for <60 sec.					
Cooling	Natural convection					
Ambient Operation Temperature	-20°C...+60°C with no derating					
Ambient Storage Temperature	-40°C...+85°C					
Environment	Humidity 95% non-condensing @ 25°C, climate class. 3k3, pollution degree 2					
Operation Altitude	3000m (9842 ft) above sea level					
ROHS	2011/65/EU, (EU)2015/863					
REACH	EG No. 1907/2006					
EMI	EN55032 class B, EN61000-6-3					
EMS	EN61000-6-2					
Safety	EN61010-1, EN61010-2-201, EN62368-1, EN60950-1, EN60204-1					
Protection Class I	PE connection required					
MTBF EN61709	500000h at 40°C and nominal load conditions					
MTTF IEC61709, SN29500	225116h (40°C/230Vac/75%)					
Housing	IP20 IEC60529					
Dimensions (HxWxD)	124x65x96mm					
Net Weight	0,99kg / 2,18 lbs					
Connector DC-In/outputs	Spring-type terminal solid max. 1,5...25mm <sup>2</sup> 16...4AWG according with IEC/EN60664-1, IEC/EN61984. Use copper conductors only. Wire stripping length 16mm. Tightening torque per terminal block is 2.4 – 4.0 Nm / 21.2 – 35.4 lbf-in					
Connector Control Signals	D-SUB DB15S IEC807-2					
Connector 24V DC-supply	Spring-type terminal solid max. 0,25...2,5mm <sup>2</sup> 24...14AWG according with IEC/EN60664-1, IEC/EN61984, Use copper conductors only. Wire stripping length 7mm. Tightening torque per terminal block is 0.4 - 0.5 Nm / 2.9 – 3.6 lbf-in					

**Key Features**

**Advantages of the UMS:**

- no mechanical wear
- no electromagnetic influences
- no high-frequency distortions
- no acoustic distortions
- inured to high stress peaks
- no contact chatters
- extreme fast signal activation
- built in controller provides active monitoring of all operation status

**Special features list:**

- big screw terminals for up to 4AWG cabling
- featuring up to 120Vdc and 80A with a 320A surge current
- MOSFET outputs offer an extreme low RDS<sub>ON</sub>

**Parallel Operation**

If you need more power – the UMS is designed to be connected in parallel

**Temperature Derating**

The maximum ambient temperature during operation is + 70°C.

The measuring point is 50mm outside the device.

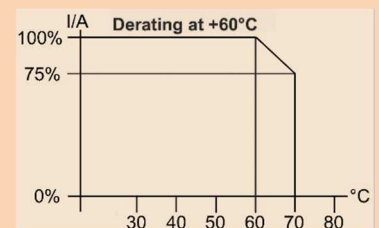

## Manual and Technical Function

Description of Signals					
Model		T	T05V	TSF	TSF05V
<b>Right Control Input</b>	When a positive signal applies to the RIGHT control input. The (+) DC-Input will be connected to DC-Output1 and the (-) DC-Input will be connected to the DC-Output2. The control-LED RIGHT lights. Pin 9+11 are closed. The signal is galvanic isolated from the DC-Inputs and from the DC-outputs.	Yes	Yes	Yes	Yes
<b>Left Control Input</b>	When a positive signal applies to the LEFT control input. The (-) DC-Input will be connected to DC-Output1 and the (+) DC-Input will be connected to the DC-Output2. The control-LED LEFT lights. Pin 10+11 are closed. The signal is galvanic isolated from the DC-Inputs and from the DC-outputs.	Yes	Yes	Yes	Yes
<b>Left &amp; Right Input</b>	When a positive signal applies to both the inputs LEFT & RIGHT at the same time or if alternatively, no signal is emitted, the DC-Outputs are open and the Master-Stop-LED lights. The signal is galvanic isolated from the DC-Inputs and from the DC-outputs.	Yes	Yes	No	No
<b>TSF Option: Left &amp; Right Input</b>	When a positive signal applies to both the inputs LEFT & RIGHT at the same time or if alternatively, no signal is emitted, the DC-Outputs are short circuit and the Master-Stop-LED lights. At the same time, the DC-outputs are also short circuit with the Minus-INPUT. The signal is galvanic isolated from the DC-Inputs and from the DC-outputs.	No	No	Yes	Yes
<b>Master Stop Input</b>	A positive signal must be emitted to the STOP input to run all functions of the UMS. The STOP input can also be used as an emergency stop. The DC-Outputs will be switched off either there is no signal emitted or it is 0V. Thus, the Master-Stop-LED lights. The sense connections stay open until the Master Stop is released. The signal is galvanic isolated from the DC-Inputs and from the DC-outputs.	Yes	Yes	Yes	Yes
<b>Sense Signal</b>	When using the sense connections for a voltage drop compensation from the load lines the wires must be twisted pair to avoid emissions and interferences. The sense cables should be connected closed to the inputs of the load. It is recommended to use a 100uF bipolar capacitor in combination with a 100nF ceramic capacitor to avoid interferences to the control signal.	Yes	Yes	Yes	Yes
<b>Monitor Signals</b>	Max. 40Vdc / 200mA resistant. All signals are galvanic isolated from the DC-Inputs and from the DC-outputs.	Yes	Yes	Yes	Yes
<b>Power LED</b>	The Power LED glows when the 24Vdc supply applies to the DC-Power inputs at the bottom of the device	Yes	Yes	Yes	Yes

**Connections Table**

Connection	Signal	Remarks
DC-Main Input (+)	DC(+) Input	See technical table on page 2
DC-Main Input (-)	DC(+) Input	
DC-Main Output 1	DC-Output 1	
DC-Main Output 2	DC-Output 2	
Power Supply SK2	24Vdc (+)	The green LED glows when the power is on. We suggest using the Camtec power supply LCR010.24 24Vdc 420mA for the UMS-models.
Power Supply SK2	24Vdc (-)	
Sub-D Pin 1	Right input	Galvanic isolated ≤60Vdc from the DC-Inputs and the DC-Outputs
Sub-D Pin 2	Left input	
Sub-D Pin 3	Stop input	
Sub-D Pin 4	GND PIN 1,2,3	
Sub-D Pin 5	Sense input (+)	
Sub-D Pin 6	Sense input (-)	
Sub-D Pin 7	Sense output (+)	
Sub-D Pin 8	Sense output (-)	
Sub-D Pin 9	Monitor right	Galvanic isolated ≤60Vdc from the DC-Inputs and the DC-Outputs Open collector
Sub-D Pin 10	Monitor left	
Sub-D Pin 11	GND PIN 9,10	
Sub-D Pin 12	not connected	
Sub-D Pin 13	not connected	
Sub-D Pin 14	not connected	
Sub-D Pin 15	not connected	

**Signal Value Table Models T & TSF**

Signal	Nominal	Min./Maximum	Response ON/ OFF	Galvanic isolated
Right	+24Vdc 5mA	+20-30Vdc 6mA	30ms / 4ms	+/- DC Input, PIN 1&2
Left	+24Vdc 5mA	+20-30Vdc 6mA	30ms / 4ms	+/- DC Input, PIN 1&2
Stop	+24Vdc 5mA	+20-30Vdc 6mA	30ms / 4ms	+/- DC Input, PIN 1&2
Monitor Right	+24Vdc 10mA	+40Vdc 200mA	30ms / 4ms	+/- DC Input, PIN 1&2
Monitor Left	+24Vdc 10mA	+40Vdc 200mA	30ms / 4ms	+/- DC Input, PIN 1&2

**Signal Value Table Models T05V & TSF05V**

Signal	Nominal	Min./Maximum	Response ON/ OFF	Galvanic isolated
Right	+5Vdc 1mA	+4,5-5,5Vdc 1mA	30ms / 4ms	+/- DC Input, PIN 1&2
Left	+5Vdc 1mA	+4,5-5,5Vdc 1mA	30ms / 4ms	+/- DC Input, PIN 1&2
Stop	+5Vdc 1mA	+4,5-5,5Vdc 1mA	30ms / 4ms	+/- DC Input, PIN 1&2
Monitor Right	+24Vdc 10mA	+40Vdc 200mA	30ms / 4ms	+/- DC Input, PIN 1&2
Monitor Left	+24Vdc 10mA	+40Vdc 200mA	30ms / 4ms	+/- DC Input, PIN 1&2

**Signal Operation Table Models T & T05V**

CTRL L	CTRL R	CTRL Stop	Mon L	Mon R	Sense Pin Connection	DC-Output (OUT) & Input (IN) Connection	LED L	LED R	LED STOP
0	0	1	OFF	OFF	ALL OPEN	ALL OPEN	OFF	OFF	ON
0	1	1	OFF	ON	5-7 / 6-8	MINUS-IN with OUT2 , PLUS-IN with OUT1	OFF	ON	OFF
1	0	1	ON	OFF	5-8 / 6-7	MINUS-IN with OUT1 , PLUS-IN with OUT2	ON	OFF	OFF
1	1	1	OFF	OFF	ALL OPEN	ALL OPEN	OFF	OFF	ON
x	x	0	OFF	OFF	ALL OPEN	ALL OPEN	OFF	OFF	ON

**Signal Operation Table Models TSF & TSF05V**

CTRL L	CTRL R	CTRL Stop	Mon L	Mon R	Sense Pin Connection	DC-Output (OUT) & Input (IN) Connection	LED L	LED R	LED STOP
0	0	1	OFF	OFF	ALL OPEN	MINUS-IN with OUT1 & OUT2 short circuited	OFF	OFF	ON
0	1	1	OFF	ON	5-7 / 6-8	MINUS-IN with OUT2 , PLUS-IN with OUT1	OFF	ON	OFF
1	0	1	ON	OFF	5-8 / 6-7	MINUS-IN with OUT1 , PLUS-IN with OUT2	ON	OFF	OFF
1	1	1	OFF	OFF	ALL OPEN	MINUS-IN with OUT1 & OUT2 short circuited	OFF	OFF	ON
x	x	0	OFF	OFF	ALL OPEN	ALL OPEN	OFF	OFF	ON

**Application Notes**

**Overview**

Many tasks formerly performed by electromagnetic relays can now be in solution Camtec new UMS electronic semiconductor relay. In comparison to a mechanic relay the UMS features no locomotive parts. The UMS Power Switch is a full semiconductor relay with built in controller. It is a 100% maintenance-free design. Under the same conditions a very good power relay is guaranteed to mostly feature around 10000 switch-loops before corrosion and aging pass to the device. The coil operating range provides earlier derating above 45°C. Our UMS works with no derating up to 60°C ambient temperature and provides unlimited switch-loops at full load.

**Future-proof and flexible**

The UMS executes different control and regulation feedings. Industrial control units open a wide field of applications to the power switch. For example, new generation dc-drives increased standards are recommended. The testing of dc-drives works under extreme conditions and pre-set. Therefore, special test units are the standard use. The UMS with its variable impedance matching offers the most suitable choice of demand.

**Parallel Operation N+1 to increase power**

If your demands exceed 320A surge current just connect some UMS in parallel. There is no external circuit recommended.

The control signals and the DC-Input and the Outputs of identical UMS modules can be parallel connected. From the control host a programme delay of 50ms is recommended for the Left/Right/Stop signal to ensure synchronous operation and balanced load sharing.

The monitoring outputs shall only be connected to one of the UMS modules. The cable section from the power supply to the UMS inputs must be of equal length and equal section.

The same applies to the UMS outputs if they are parallel connected to the load. The use of star points or power bars can be helpful. Make sure that the sense is not connected.

Connecting the sense lines while operating the UMS in parallel can cause trouble to the control circuit.

**Power Crash Control (PCC)**

The UMS features a special temperature and a voltage control so that in switch over mode (e.g., rotating direction changes) no shortcut occurs (Power Crash Control). The turn-over of the sense control works automatically. All control inputs and outputs are galvanic insulated by photo couplers.

**Sample application:**

Example:  
UMS with Camtec programmable power supply unit on a DC-motor test bench.

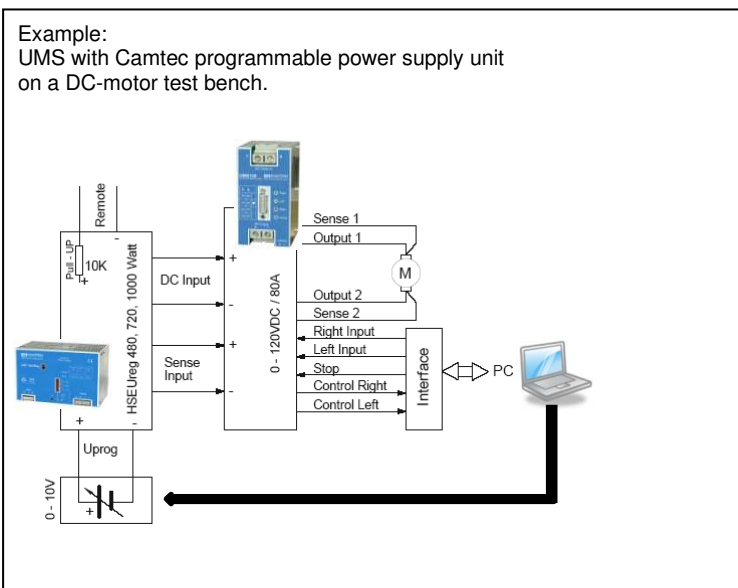

**Applications**

- DC motor drives
- valve control systems
- feeder control systems
- brake systems
- battery backup systems

**Mechanics & Installation Instruction of the UMS**

Stable metal/aluminium housing IP20. To allow adequate convection, a free air space of 50mm (top/bottom) and 10mm (sidewalls) is required; and for active devices 15mm space from the sidewalls. One can use the DIN-Rail installation (equipped standard) with our patented 35mm DIN-Rail bracket according to EN60715. It is easy to mount/dismount while snapping it onto the 35mm DIN-Rail - no tools necessary. **It is not allowed to install the UMS in other mounting direction then below drawings.**

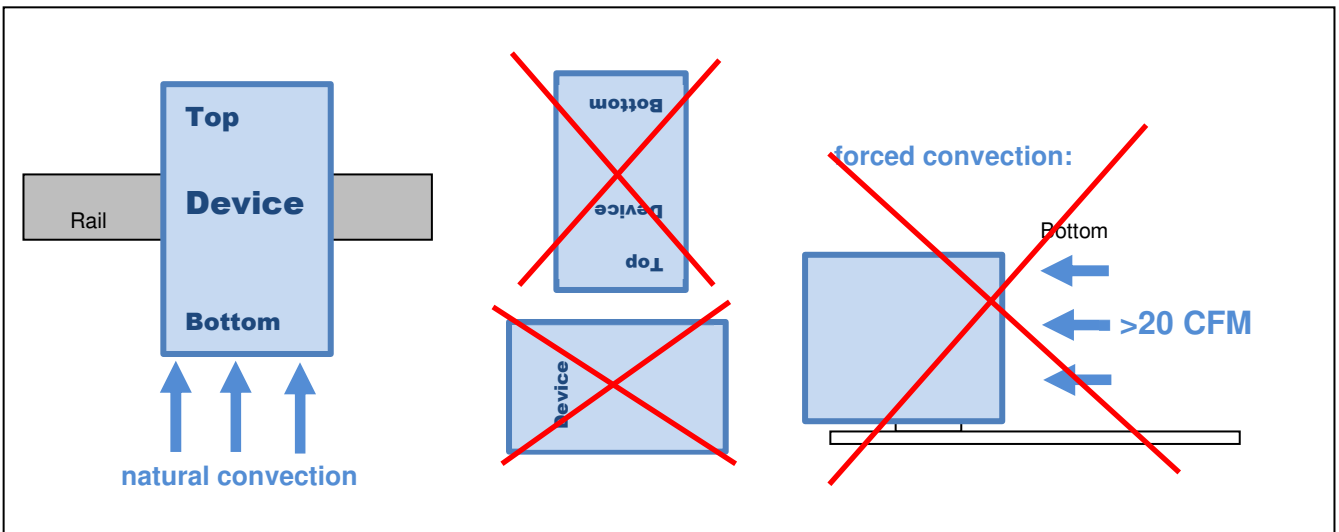
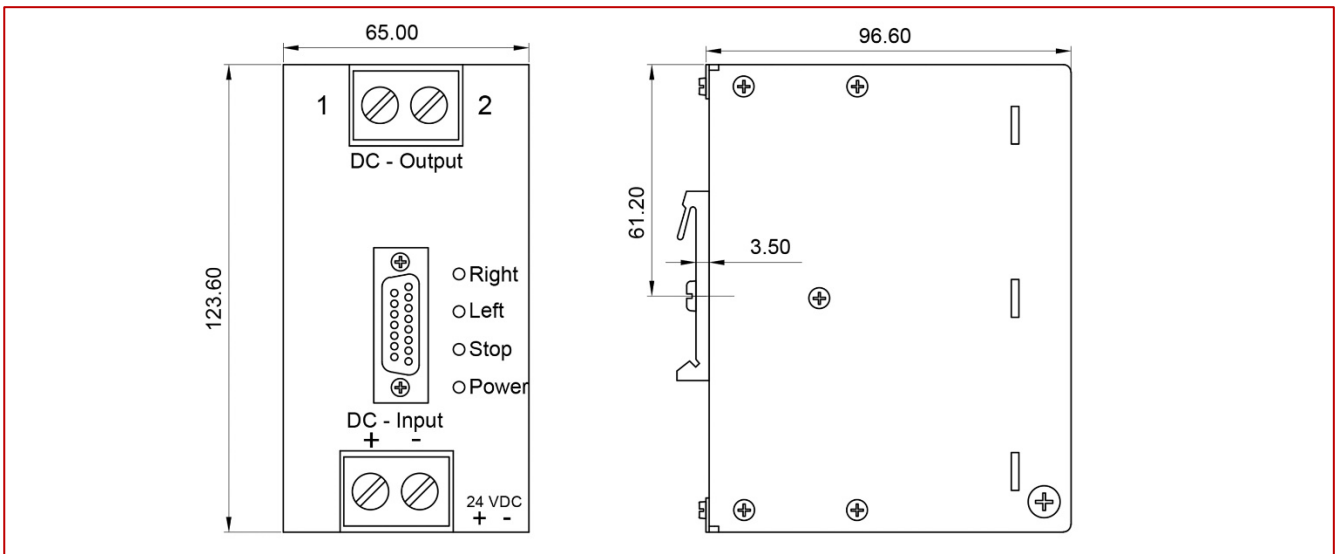

Mounting Instruction

### Coating Option

We offer the UMS-series with optional coating. It is to be used in e.g., dusty, dirty, high humidity, or in awaiting quick temperature changes. Short circuit and corrosion at print board lines and at solder points can be prevented. The coat itself is a transparent acrylic resin. Peters SL 1306 N-FLZ (transparent) IEC60216-1 2001, IPC-CC-830B, UL listed as permanent coating File No.: E80315 , UL94V-0

### Ordering Codes

Product Code	VDC/A	Power	Option	Article Number
UMS00025.20T(R2)	30V/20A	600W	-	3041040113CA
UMS00025.15T(R2)	40V/15A	600W	-	3041040112CA
UMS00025.10T(R2)	60V/10A	600W	-	3041040111CA
UMS00025.20T05V(R2)	30V/20A	600W	5V CTRL signal	3041040223CA
UMS00025.15T05V(R2)	40V/15A	600W	5V CTRL signal	3041040222CA
UMS00025.10T05V(R2)	60V/10A	600W	5V CTRL signal	3041040221CA
UMS00025.20TSF(R2)	30V/20A	600W	Motor Stop Function	3041040333CA
UMS00025.15TSF(R2)	40V/15A	600W	Motor Stop Function	3041040332CA
UMS00025.10TSF(R2)	60V/10A	600W	Motor Stop Function	3041040331CA
UMS00025.20TSF05V(R2)	30V/20A	600W	Motor Stop Function & 5V CTRL signal	3041040443CA
UMS00025.15TSF05V(R2)	40V/15A	600W	Motor Stop Function & 5V CTRL signal	3041040442CA
UMS00025.10TSF05V(R2)	60V/10A	600W	Motor Stop Function & 5V CTRL signal	3041040441CA
UMS00050.40T(R2)	30V/40A	1200W	-	3041040013CA
UMS00050.30T(R2)	40V/30A	1200W	-	3041040012CA
UMS00050.20T(R2)	60V/20A	1200W	-	3041040011CA
UMS00050.40T05V(R2)	30V/40A	1200W	5V CTRL signal	3041040213CA
UMS00050.30T05V(R2)	40V/30A	1200W	5V CTRL signal	3041040212CA
UMS00050.20T05V(R2)	60V/20A	1200W	5V CTRL signal	3041040211CA
UMS00050.40TSF(R2)	30V/40A	1200W	Motor Stop Function	3041040023CA
UMS00050.30TSF(R2)	40V/30A	1200W	Motor Stop Function	3041040022CA
UMS00050.20TSF(R2)	60V/20A	1200W	Motor Stop Function	3041040021CA
UMS00050.40TSF05V(R2)	30V/40A	1200W	Motor Stop Function & 5V CTRL signal	3041040413CA
UMS00050.30TSF05V(R2)	40V/30A	1200W	Motor Stop Function & 5V CTRL signal	3041040412CA
UMS00050.20TSF05V(R2)	60V/20A	1200W	Motor Stop Function & 5V CTRL signal	3041040411CA
UMS00100.80T(R2)	30V/80A	2400W	-	3041040001CA
UMS00100.60T(R2)	40V/60A	2400W	-	3041040002CA
UMS00100.40T(R2)	60V/40A	2400W	-	3041040003CA
UMS00100.20T(R2)	120V/20A	2400W	-	3041040004CA
UMS00100.80T05V(R2)	30V/80A	2400W	5V CTRL signal	3041040201CA
UMS00100.60T05V(R2)	40V/60A	2400W	5V CTRL signal	3041040202CA
UMS00100.40T05V(R2)	60V/40A	2400W	5V CTRL signal	3041040203CA
UMS00100.20T05V(R2)	120V/20A	2400W	5V CTRL signal	3041040204CA
UMS00100.80TSF(R2)	30V/80A	2400W	Motor Stop Function	3041040301CA
UMS00100.60TSF(R2)	40V/60A	2400W	Motor Stop Function	3041040302CA
UMS00100.40TSF(R2)	60V/40A	2400W	Motor Stop Function	3041040303CA
UMS00100.20TSF(R2)	120V/20A	2400W	Motor Stop Function	3041040304CA
UMS00100.80TSF05V(R2)	30V/80A	2400W	Motor Stop Function & 5V CTRL signal	3041040401CA
UMS00100.60TSF05V(R2)	40V/60A	2400W	Motor Stop Function & 5V CTRL signal	3041040402CA
UMS00100.40TSF05V(R2)	60V/40A	2400W	Motor Stop Function & 5V CTRL signal	3041040403CA
UMS00100.20TSF05V(R2)	120V/20A	2400W	Motor Stop Function & 5V CTRL signal	3041040404CA
Optional Connector	-	-	For necessary external 24Vdc supply	3520037



## Connections

### Clamping Yoke Connector Specifications

	Optional Connection Plugs Input	Optional Connection Plug 24Vdc Supply
Tightening torque min. – max.	2,4 – 4,0Nm (blade 1,0x5,5 DIN5264)	0,4 – 0,5Nm (blade 0,6x3,5 PH1 PZ1)
Touch-safe protection acc. to DIN VDE 0470	Not applicable	Not applicable
Clamping range, min. – max.	1,5 – 25,0mm <sup>2</sup> / AWG16 – AWG4	0,2 – 4,0mm <sup>2</sup> / AWG26 – AWG12
Solid, H05(07) V-U min. – max.	1,5 – 16,0mm <sup>2</sup>	0,2 – 4,0mm <sup>2</sup>
Stranded, H05(07) V-U min. – max.	6,0 – 25,0mm <sup>2</sup>	Not applicable
Flexible, H05(07) V-U min. – max.	1,5 – 25,0mm <sup>2</sup>	0,2 – 4,0mm <sup>2</sup>
w. plastic collar ferrule, DIN 46228 pt 4 min. – max.	1,5 – 16,0mm <sup>2</sup>	0,2 – 2,5mm <sup>2</sup>
w. wire end ferrule, DIN 46228 pt 1, min. – max.	1,5 – 16,0mm <sup>2</sup>	0,2 – 4,0mm <sup>2</sup>
Plug gauge in accordance with EN 60999 a x b; ø	6,9 x 6,9mm	2,8 x 2,4mm; 2,5mm
Pitch (P)	15,00mm	5,08mm

### Electrical Safety (Factory-Test / Field-Test Owner)

	T	A <sup>1)</sup>
Type Test	60s	500Vdc
Factory Test	5s	500Vdc
Field Test	2s	500Vdc
Cut-off current setting	>1mA	

<sup>1)</sup> UMS00100.20T... models = 1500Vdc

Type and factory test are the manufacturer. While repeating damage can happen to the power supply unit. For the field test (owner) follow the below instruction:

- Use suitable test equipment, raising the voltage slowly
- Use only test voltages of 50/60Hz. The outputs are unearthed and therefore they have no resistance to GND/PE.
- Use only specially insulated screwdriver to trim the Ua/Ia.

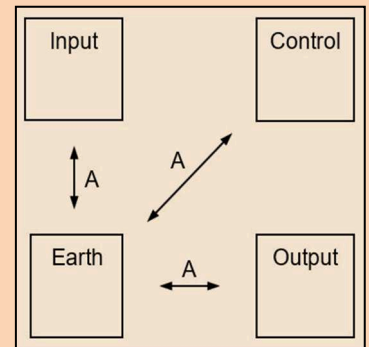

**Safety regulations: Please read these instructions completely before using the equipment. Keep these instructions on to hand. The device may only be operated by trained specialist staff.**

#### Installation:

- The device is designed for devices and systems that meet the standard requirements for hazardous voltages, power, and fire prevention.
- Installation and service only by trained persons. The AC power must be switched off. The work is to be labelled; accidental reconnection of the system must be prevented.
- Opening the device, its modification, loosening bolts, or operation outside the specified herein specification or in an unsuitable environment, has the immediate loss of warranty to follow. We disclaim any responsibility for any resulting damage to persons or things.

#### Warning:

**Non-compliance these warnings can result in fire and serious injury or death.**

- Never operate device without PE connection.
- Allow neat and professional cabling.
- Never open nor try to repair the unit. Inside are dangerous voltages that can cause electrical shock hazard.
- Avoid metal pieces or other conductive material to fall into the item
- Do not operate the device in damp or wet conditions
- Do not operate the unit under EX-conditions



All parameters in the data sheet base on 15 minutes run-in @ full load / 25°C / 230Vac 50/60Hz, as otherwise stated.