

# RED00202

# DIN Rail

Made in Germany

## Active N+1 Dual Redundancy Management Module 2x 50A Integrated low / overvoltage detection, Input / Output floating

### Specification:

- Detects low voltage and overvoltage
- -20°C...+70°C ambient temperature
- Very low voltage drop
- Screw terminal plugs for 22...6AWG
- For 2x 50A loads
- IP20 metal housing
- Schottky barrier decoupling diodes
- Efficiency  $\geq 97\%$
- DIN-Rail TS35 mounting
- Reverse polarity protected
- Monitoring relay, floating
- Adjustable voltage drop out

### Available DC-voltages:

12...28Vdc, 36...60Vdc, 90...125Vdc

### Applications:

- . DC redundant power supply
- . Decoupling from battery banks
- . Reverse voltage protection
- . Drop-out Voltage control



## Technical Data Table

Model	RED00202A	RED00202B	RED00202C
Channel Inputs	V1in / V2in	V1in / V2in	V1in / V2in
DC-Input Voltage *)	(0)12V...28Vdc	36V...60Vdc	90V...125Vdc
DC-Input Upper Margin Vo	fix +36V ± 5%	fix +75V ± 5%	fix +140V ± 5%
Hysteresis Vo	~1.5V	~1.5V	~1.5V
Drop-Out Voltage Set Range	+8Vdc...+28Vdc	+24V...+60Vdc	+60V ...+135Vdc
Low Rate Hysteresis Vu	~1.5V	~1.5V	~1.5V
Maximum Input Current	2x 50A	2x 28A	2x 9,1A
Maximum Output Current	1x 50A (1000W)	1x 28A	1x 9,1A
Voltage Drop, Input to Output	500mV typical	600mV typical	700mV typical
DC Input	Floating		
DC Output	Floating		
Power Good Relay	Change over contact		
Relay contact load	48Vdc 500mA max.		
Relay contact separation	protective electrical insulation ≤60Vdc		
Cooling	Natural convection		
Ambient temperature	-20°C...+70°C		
Storage temperature	-40°C...+85°C		
EMI	EN55022 class B / EN61000-3-2		
EMS	EN61000-6-2,3		
Safety	EN60950-1, IEC60204-1		
Safety Class	1A, VDE0805, VDE0100		
Housing	IP20 IEC60529		
Creepage paths	> 2mm		
Humidity in Operation	90% non condensing @ 25°C		
Climatic Class	2K3		
Pollution Rate	II A		
Altitude in Operation	3000m (9842 ft) above sea level		
MTBF (IEC61709)	500000h at 40°C, nominal load conditions		
MTTF IEC61709, SN29500	235128h (40°C/230Vac/75%)		
ROHS conformity	ROHS Directive 2011/65/EU		
REACH conformity	REACH Directive 1907/2006		
Dimensions (HxWxD)	130x62x115mm		
Weight	1000g		
Connectors	Screw terminals 20...6AWG (76A/40°C)		

\*) other output voltages upon request

## Manual and Technical Function

### Technical Description

When breakdowns cost a lot of money and service is hindered, it is advisable to operate the power supply management redundant. The redundant module RED00202 is designed for applications from 0Vdc to 125Vdc. DC-outputs from N+1 power supply units will be decoupled (equal power supplies and output voltages are recommended).

If a breakdown occurs to one of the connected power supply modules, the other one will take over with no voltage drop to the system. While normal operation the load will be partitioned equal to each of the connected power supplies. The RED00202 power good relay (change over contact) features continuous control over the conditions of the connected power supplies. If one power supply fails the relay indicates that the remaining power supply takes over. The drop out voltage  $V_u$  can be adjusted via the front-sided control potentiometer ADJ. The upper margin  $V_o$  is a fixed value (see technical data table).

The DC-Input of the RED00202 corresponds to the output voltage of the power supplies installed. The GND-Input of the RED00202 is evident for the own supply only. The voltage drop between DC-input and DC-output is 500mV ... 700mV (see technical data table).

### Current voltage ratio graph

#### Voltage control specification:

The change-over contact over the control relay is closed when  $V_{in}$  ranges between  $V_u$  and  $V_o$  (o.k. mode – LED of each input lights green). Relay drops out when  $V_{in} < V_u$  or  $V_{in} > V_o$  (low voltage & over voltage control).

The upper voltage margin  $V_o$  is fixed while the drop out voltage can be set with the potentiometer ADJ (see technical data table)

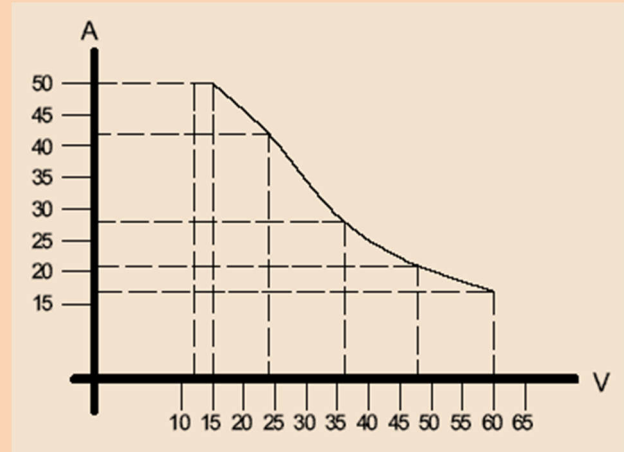

The RED00202A model can also be used smaller than 12Vdc. Please note that the DC-ok relay and the ADJ potentiometer will not function below 12Vdc.

Current Voltage Input Ration RED00202A	2x 50A
Current Voltage Input Ration RED00202B	2x 11,2A
Current Voltage Input Ration RED00202C	2x 9,1A

## Connections und Functions Table

Function	Signal	Remarks
V1in	DC(+) Input 1	Connect to voltage of power supply unit 1
V2in	DC(+) Input 2	Connect to voltage of power supply unit 2
Vout	DC(+) Output Sum	Connect to (+) of the load
GND	Common GND	Connect (-) of power supply unit 1&2 and the (-) of the connected load
Relay	Change over contact	Left position (DC-OK), Right position (DC-Fail) DC-Fail indicates that one of the connected power supplies V1 or V2 operates below the drop out voltage
V1in LED	LED signal	OFF = no voltage, YELLO = Low Voltage
V2in LED	LED signal	OFF = no voltage, YELLO = Low Voltage
ADJ	Potentiometer	Set the drop out voltage together for V1 and V2

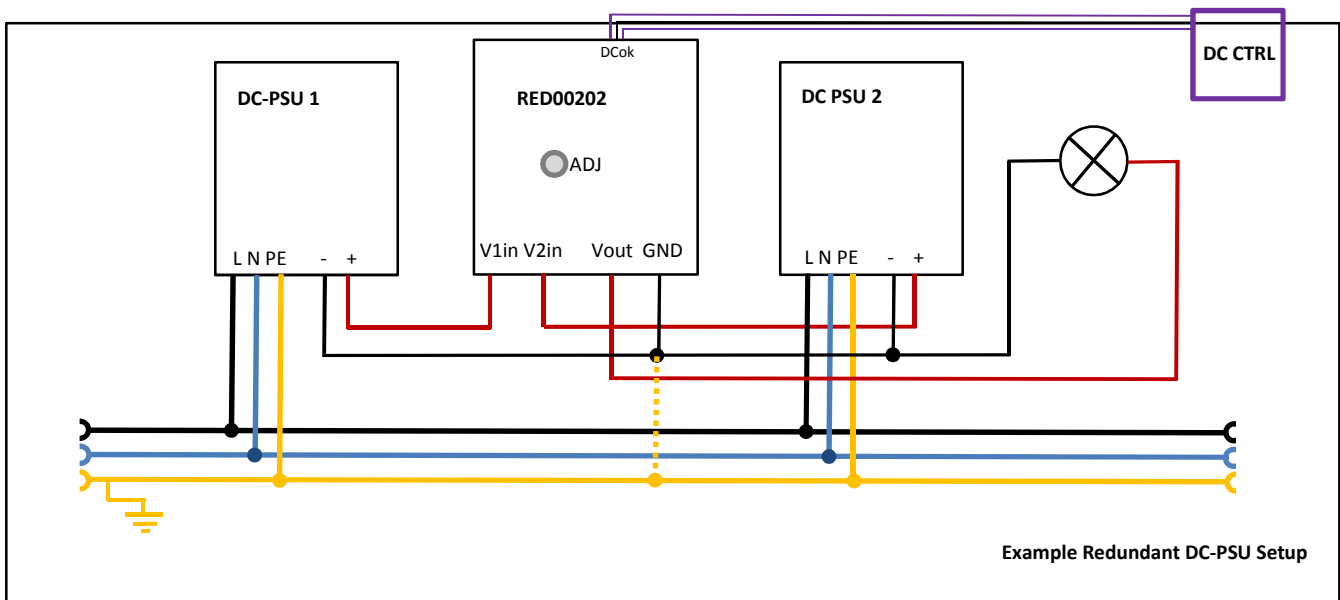

## Stock Numbers

Model	Volt	Power	Remarks	Ordering Article Number
RED00202A	0 – 28Vdc	1000W	<12Vdc no DC-OK relay function	3041049001CA
RED00202B	36 – 60Vdc	1000W		3041049002CA
RED00202C	90 – 125Vdc	1000W		3041049003CA
SK2 Plug 10pcs/pack	-	-	For DC-ok Relay connection	3520038

## Coating Option

We offer the RED00202 series with an optional coating. It is to be used in e.g. dusty, dirty, high humidity area or in awaiting quick temperature changes. Short circuit and corrosion at print board lines and at solder points can be prevented. The coat itself is a transparent acrylic resin.

Peters SL 1306 N-FLZ (transparent) IEC60216-1 2001, IPC-CC-830B, UL listed as permanent coating FileNo.: E80315 , UL94V-0

Ordering Information: add extension **CO** to the model name (example): RED00202C.**CO**

(Please note that the MOQ for the models with coating is 5pcs per lot)

## Mechanics

Stable metal/aluminium housing IP20. To allow adequate convection, a free air space of 30mm (top/bottom) and 5mm (sidewalls) is required; for active devices 10mm space from the sidewalls. For free air convection it is necessary to install the unit horizontal. Use the DIN-Rail installation (equiped standard) with the patented 35mm DIN-Rail brackets according to EN60275. It is easy to mount/dismount while snapping it onto the 35mm DIN-Rail - no tools are necessary.

For service or install conditions the system has be circuit switched to voltage free. The housing screws are recommended for the GND-connect – do not remove one of it.

For operation >60Vdc connecting the GND-connection of the housing to PE is recommended to prevent from any kind of interferences to the supply system.

The IP20 aluminium housing provides VDE approved ventilation slots. Safe fit on DIN-Rail: no tool is necessary to snap on or dismount it from the TS35mm-DIN-Rail. An optional wall mount kit is available upon request.

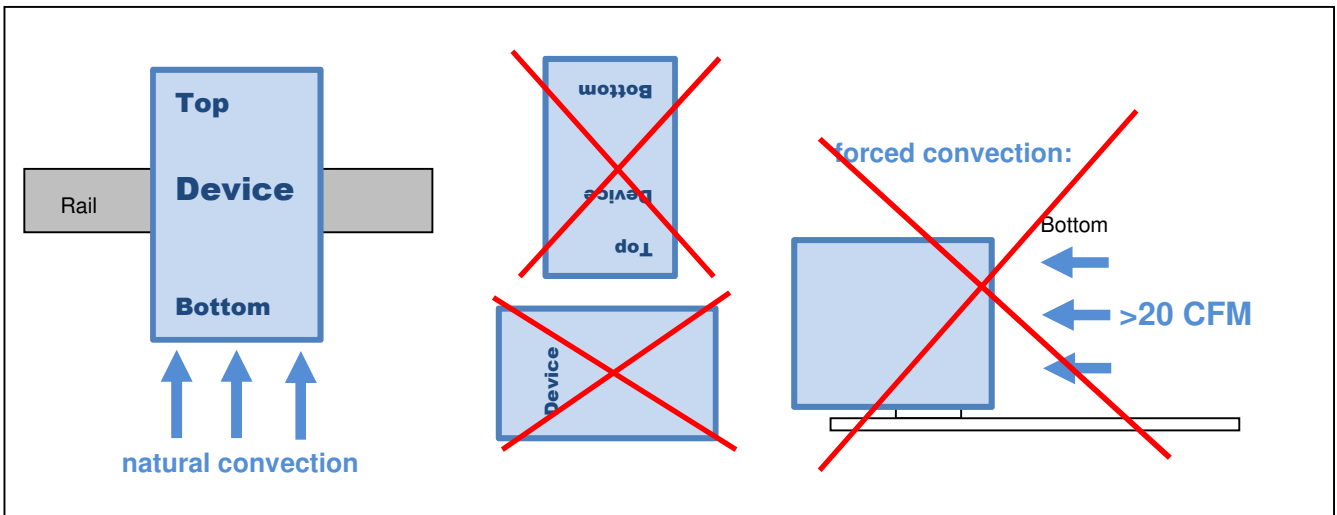
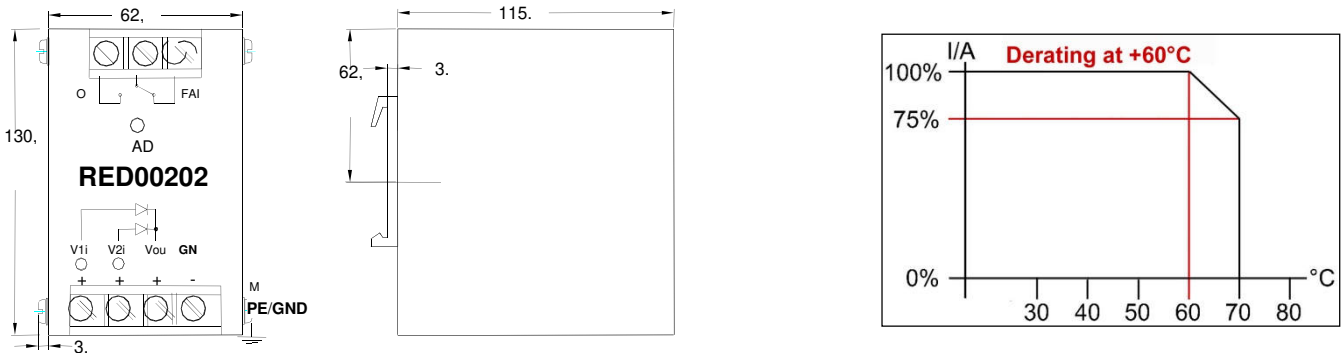

### Mounting Instruction

**Safety Instructions:** Please read all warnings and advices carefully before installing or operating this device. Retain this operation manual always ready to hand. The device must be installed by specialist staff only.

### Installation:

- 1.) The unit is designed for systems fulfilling the safety norms of dangerous voltages/energy and fire prevention
- 2.) Installation is restricted to specialists only, make sure that the DC wire system is free of voltage
- 3.) Opening the device, making any modifications to it, dismounting any screws from it, operating the item out of specification and/or using it in appropriate area will inevitably result in loosing manufactureres guarantee; we decline taking any responsibility for risk of damages caused to someones health or to any installed system.

### Warnings:

Disregard these warnings can cause fire, electric shock, serious accident and death.

1. Never operate the device without Protective Earth Conductor.
2. Before connecting the item to the DC wire system make all wires free of voltage and assure accidently switch on.
3. Allow neat and professional cabling.
4. Never open nor try to repair the device by yourself. Inside are dangerous voltages that can cause electric shock hazard.
5. Avoid metal pieces or other conductive material to fall into the item.
6. Do not operate the device under damp or wet conditions
7. It is prohibited to operate the unit under Ex conditions or in Ex-Area



All parameters in the data sheet base on 15 minutes run-in @ full load / 25°C / 230Vac 50/60Hz, as otherwise stated.