

## Features

- ◆ Smallest encapsulated 30 W converter
- ◆ 2" x 1" x 0.4" shielded metal package
- ◆ Ultra wide 4:1 input voltage range
- ◆ Single- dual- and triple output models
- ◆ Very high efficiency up to 91%
- ◆ Operating temp. range -40°C to +75°C
- ◆ I/O isolation 1500 VDC
- ◆ Over temperature and short circuit protection
- ◆ Remote On/Off
- ◆ Adjustable output voltage
- ◆ 3-year product warranty



The TEN 30WIN series is a family of high performance 30W dc-dc converter modules featuring ultra wide 4:1 input voltage ranges in a compact low profile case with industry-standard footprint. Standard features include remote On/Off, output voltage trimming, over voltage protection, under voltage lockout, over temperature and short circuit protection.

Typical applications for these products are battery operated equipment and distributed power architectures in communication and industrial electronics, everywhere where isolated, tightly regulated voltages are required and space is limited on the PCB.

## Models

Order code	Input voltage range	Output 1	Output 2	Output 3	Efficiency typ.
TEN 30-2407WIN	9 – 36 VDC (24 VDC nominal)	1.5 VDC / 8.5 A			80 %
TEN 30-2409WIN		2.5 VDC / 8.0 A			83 %
TEN 30-2410WIN		3.3 VDC / 7.5 A			86 %
TEN 30-2411WIN		5.1 VDC / 6.0 A			88 %
TEN 30-2412WIN		12 VDC / 2.5 A			89 %
TEN 30-2413WIN		15 VDC / 2.0 A			89 %
TEN 30-2421WIN		+ 5 VDC / 3.0 A	-5 VDC / 3.0 A		88 %
TEN 30-2422WIN		+12 VDC / 1.25 A	-12 VDC / 1.25 A		87 %
TEN 30-2423WIN		+15 VDC / 1.0 A	-15 VDC / 1.0 A		87 %
TEN 30-2433WIN		3.3 VDC / 5.0 A	+12 VDC / 0.42 A	-12 VDC / 0.42 A	86 %
TEN 30-2434WIN		3.3 VDC / 5.0 A	+15 VDC / 0.33 A	-15 VDC / 0.33 A	86 %
TEN 30-2431WIN		5 VDC / 4.0 A	+12 VDC / 0.42 A	-12 VDC / 0.42 A	88 %
TEN 30-2432WIN		5 VDC / 4.0 A	+15 VDC / 0.33 A	-15 VDC / 0.33 A	88 %
TEN 30-4807WIN		18 – 75 VDC (48 VDC nominal)	1.5 VDC / 8.5 A		
TEN 30-4809WIN	2.5 VDC / 8.0 A				84 %
TEN 30-4810WIN	3.3 VDC / 7.5 A				86 %
TEN 30-4811WIN	5.1 VDC / 6.0 A				88 %
TEN 30-4812WIN	12 VDC / 2.5 A				90 %
TEN 30-4813WIN	15 VDC / 2.0 A				91 %
TEN 30-4821WIN	+ 5 VDC / 3.0 A		-5 VDC / 3.0 A		88 %
TEN 30-4822WIN	+12 VDC / 1.25 A		-12 VDC / 1.25 A		88 %
TEN 30-4823WIN	+15 VDC / 1.0 A		-15 VDC / 1.0 A		88 %
TEN 30-4833WIN	3.3 VDC / 5.0 A		+12 VDC / 0.42 A	-12 VDC / 0.42 A	86 %
TEN 30-4834WIN	3.3 VDC / 5.0 A		+15 VDC / 0.33 A	-15 VDC / 0.33 A	86 %
TEN 30-4831WIN	5 VDC / 4.0 A		+12 VDC / 0.42 A	-12 VDC / 0.42 A	88 %
TEN 30-4832WIN	5 VDC / 4.0 A		+15 VDC / 0.33 A	-15 VDC / 0.33 A	88 %

### Input Specifications

Input current at no load (nominal input)	12 & 15 VDC / $\pm 12$ & $\pm 15$ VDC models, 24 V: other models, 24 V: $\pm 12$ & $\pm 15$ V models, 48 V: other models, 48 V:	30 mA typ. 100 mA typ. 15 mA typ. 55 mA typ.
Input current at full load (nominal input)	1.5 VDC model, 24 V: 2.5 VDC model, 24 V: 3.3 VDC model, 24 V: other models, 24 V: 1.5 VDC model, 48 V: 2.5 VDC model, 48 V: 3.3 VDC model, 48 V: other models, 48 V:	700 mA typ. 1050 mA typ. 1250 mA typ. 1500 mA typ. 350 mA typ. 520 mA typ. 630 mA typ. 750 mA typ.
Start-up voltage / under voltage lockout	24 V models: 48 V models:	9 VDC / 8 VDC (typ.) 18 VDC / 16 VDC (typ.)
Surge voltage (100 msec. max.)	24 V models: 48 V models:	50 VDC max. 100 VDC max
Conducted noise (input)	24 V models: 48 V models:	EN 55022 class A with input capacitor 4.7 $\mu$ F / 50 V 1812 MLCC 2.2 $\mu$ F / 100 V 1812 MLCC

### Output Specifications

Voltage set accuracy		$\pm 1$ % ( $\pm 5$ % for auxiliary outputs)
Output voltage adjustment (only for single output models)		$\pm 10$ % with external resistor (see page 3)
Regulation	– Input variation – Load variation	single- and dual output models: 0.2 % max. triple output models: 1 % / 5 % max. (main / auxiliary) single output models: 0.5 % max. (0 – 100 %) dual output models balanced load: 1 % max. (0 – 100 %) dual output models unbalanced load: 5 % max. (25 / 100 %) triple output models (main/auxiliary): 1 % max. / 5 % max. (10 – 100 %)
Minimum load	single- and dual output models: triple output models:	not required 10% of rated max current on each output (operation at lower load condition will not damage the converters. However, they may not meet all listed specifications)
Temperature coefficient		$\pm 0.02$ %/K max.
Ripple and noise (20 MHz Bandwidth)	1.5 V – 5.1 VDC models: triple output models: other models:	100 mVpk-pk. typ. 50 / 75 mVpk-pk typ. (main / auxiliary) 150 mVpk-pk typ.
Start up time (nominal Vin and constant resistive load)		30 ms typ.
Transient response time (25% load change)		250 $\mu$ s typ.
Short circuit protection		indefinite (automatic recovery)
Over load protection		150 % of lout max. typ.
Thermal shutdown		at +115°C typ.
Over voltage protection	1.5 VDC models: 2.5 VDC models: 3.3 VDC models: 5.1 VDC models: 12 VDC models: 15 VDC models:	2.0 V 3.3 V 3.9 V 6.2 V 15 V 18 V
Capacitive load output models	1.5 – 3.3 VDC models: 5.1 VDC models: 12 & 15 VDC models: $\pm 5$ VDC models: other dual output models: 3.3 VDC triple output models: 5.1 VDC triple output models:	20'000 $\mu$ F max. 14'000 $\mu$ F max. 2'000 $\mu$ F max. $\pm 3$ '000 $\mu$ F max. $\pm 1$ '300 $\mu$ F max. 15'000 / $\pm 220$ $\mu$ F max. (main / auxiliary) 8'000 / $\pm 220$ $\mu$ F max. (main / auxiliary)

All specifications valid at nominal input voltage, full load and +25°C after warm-up time unless otherwise stated.

### General Specifications

Temperature ranges	<ul style="list-style-type: none"> <li>- Operating</li> <li>- Case temperature</li> <li>- Storage</li> </ul>	-40°C to +75°C +105°C max. -55°C to +125°C
Derating		3.5 %/K above +60°C
Humidity (non condensing)		95 % rel. H max.
Thermal inpedance	<ul style="list-style-type: none"> <li>- Natural convection</li> <li>- Natural convection with heat sink</li> </ul>	12°C/W 10°C/W
Reliability, calculated MTBF (MIL-HDBK-217F, at +70°C, ground benign)	single- and dual output models: triple output models:	1.2 Mio. h 1.1 Mio. h
Isolation voltage (60 sec.)	- Input / Output	1500 VDC
Isolation resistance	- Input / Output	>1000 M Ohm
Isolation capacitance	- Input / Output	1500 pF max.
Remote On/Off	<ul style="list-style-type: none"> <li>- On:</li> <li>- Off:</li> <li>- Off idle current:</li> </ul>	3.0 to 12 VDC or open circuit. 0 to 1.2 VDC or short circuit pin 3 and pin 2 3 mA max.
Switching frequency (pulse width modulation PWM)	single- and dual output models: triple output models:	430 kHz typ. 400 kHz typ.
Thermal shock, mechanical shock & vibration	- Test conditions	EN 61373, MIL-STD-810F <a href="http://www.tracopower.com/products/mil810.pdf">www.tracopower.com/products/mil810.pdf</a>
Safety standards		UL 60950-1, IEC/EN 60950-1
Safety approvals	- UL/cUL	<a href="http://www.ul.com">www.ul.com</a> -> certifications -> File e188913

**Application note:** [www.tracopower.com/products/ten30win-application.pdf](http://www.tracopower.com/products/ten30win-application.pdf)

### Output Voltage Adjustment (for single output models only)

#### Trim up

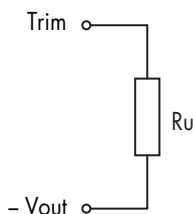

#### Trim down

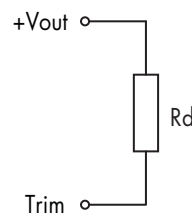

Nominal output voltage at open Trim input!

#### Ru [kohm]

output	1.5	2.5	3.3V	5.1V	12V	15V
+5%	0.56	4.3	6.8	5.1	43	47
+10%	0.051	0.33	0.75	0.75	4.3	1.8

#### Rd [kohm]

output	1.5	2.5	3.3V	5.1V	12V	15V
-5%	0.68	6.2	8.2	6.2	56	56
-10%	0.062	0.75	0.62	0.82	5.6	2.2

### Physical Specifications

Casing material		copper, nickel plated
Baseplate material		none conductive FR4
Potting material		epoxy (UL 94V-0 -rated)
Weight		31 g (1.1oz)
Soldering temperature		max. 265°C / 10 sec.
Environmental compliance	<ul style="list-style-type: none"> <li>- Reach</li> <li>- RoHS</li> </ul>	<a href="http://www.tracopower.com/products/reach-declaration.pdf">www.tracopower.com/products/reach-declaration.pdf</a> RoHS Directive 2011/65/EU

### Outline Dimensions

Single- and dual output models

Triple output models

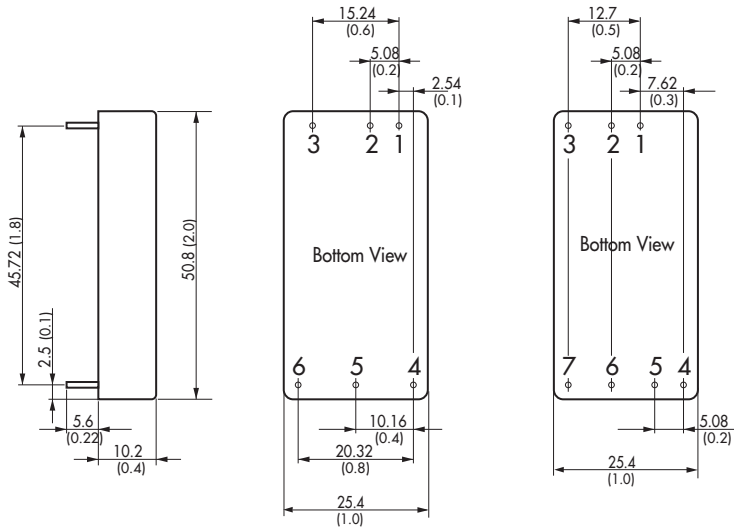

### Pin-Out

Pin	Single	Dual	Triple
1	+Vin (Vcc)	+Vin (Vcc)	+Vin (Vcc)
2	-Vin (GND)	-Vin (GND)	-Vin (GND)
3	Remote On/Off	Remote On/Off	Remote On/Off
4	+Vout 1	Output 1	Output 2
5	-Vout 1	Common	Output 3
6	Trim	Output 2	Common
7	No pin	No pin	Output 1

Dimensions in [mm], ( ) = Inch  
Pin diameter:  $1.0 \pm 0.1$  ( $0.04 \pm 0.004$ )  
Pin pitch tolerances:  $\pm 0.25$  ( $\pm 0.01$ )  
Case tolerances:  $\pm 0.5$  ( $\pm 0.02$ )

### Heat-Sink (Option)

Order code: **TEN-HS1**

(cont.: heat-sink, thermal pad, 2 clamps)

Material: Aluminum

Finish: Anodic treatment (black)

Weight: 17g (0.60oz) without converter

Thermal impedance after assembling: 10 K/W



#### Note:

Before attaching the heatsink, the product label on converter has to be removed for optimal performance.

For volume orders we can supply the converters with heatsink already mounted.

Please contact us for a relative quotation.

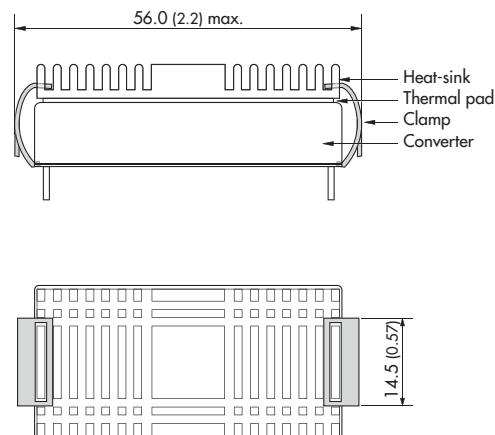

Specifications can be changed without notice! Make sure you are using the latest documentation, downloadable at [www.tracopower.com](http://www.tracopower.com)