

UMS

DIN Rail

Made in Germany

Models UMS...T/T05V/TSF/TSF05V

Electronic DC Power Switch Relay 30 – 120Vdc, 10A – 320A
DC-MOSFET Relay 600 - 2400W

Short Specification:

- Unlimited operational switches
- Up to 2400W power switching capacity
- Parallel operation N+1 power increase
- Switching current up to 320A
- Switching voltage up to 120Vdc
- Mounting space only 50mm
- Free air convection on DIN Rail 35mm
- Interference free EMC behaviour
- Power MOSFETs with Low RDSon
- Control In-/outputs galvanic isolated
- Left-/right operation mode
- Left-/right control monitor
- Motor STOP! signal optional
- Sense control
- Terminals AWG16-AWG4 (0,5-16mm²)
- IEC60950-1, IEC60204-1
- EMC: EN55022 class B

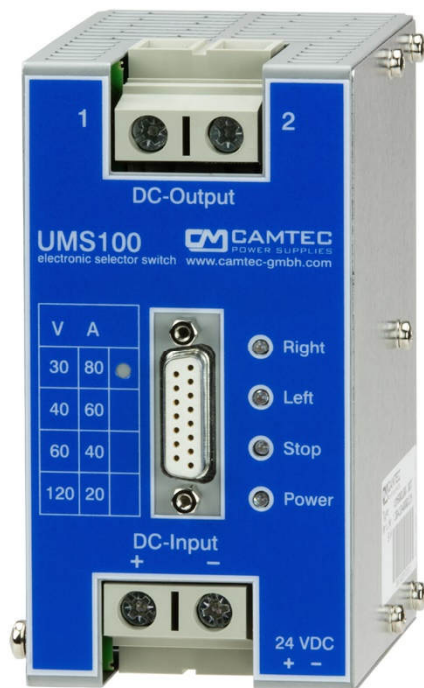

Intelligent Power Switch for Automation & Drives – replaces excessive conventional relay solutions

Applications:

DC Motor drives, breaks, valves, slide feeds, magnet coils, battery bank switching

Control functions:

The Camtec Power-Crash-Control circuit protects from short circuits while switching over. The sense polarity is reversed congruent to the outputs.

Control In-/Outputs:

Galvanic isolated with photo couplers



p.1/8 (06/2016.02.1)

(Technical changes and errors. This product may not readily be used in life support systems.)

Technical Data Table

Power Supply	24Vdc \pm 20% (22-30Vdc/100mA) external industrial level power supply recommended					
Input Rating	typ. 100mA					
Basic Model	UMS00025.10T	UMS00025.15T	UMS00025.20T	UMS00050.20T	UMS00050.30T	UMS00050.40T
Rated Voltage	60V	40V	30V	60V	40V	30V
Rated Current	10A	15A	20A	20A	30A	40A
Boost \leq 10ms	40A	60A	80A	80A	120A	160A
RDSon Tc=25°C	32.9m Ω	12.3m Ω	9.9m Ω	17.1m Ω	6.8m Ω	5.6m Ω
Basic Model	UMS00100.20T	UM00100.40T	UMS00100.60T	UMS00100.80T		
Rated Voltage	120Vdc	60Vdc	40Vdc	30Vdc		
Rated Current	20A	40A	60A	80A		
Boost \leq 10ms	80A	100A	240A	320A		
RDSon Tc=25°C	26.8m Ω	9.2m Ω	4.1m Ω	3.5m Ω		
Safety Recommendation >60Vdc	>60Vdc we advise to use ADTW201 for galvanic insulation					
Voltage error sequence	Input-/output: +20% for <60 sec.					
Cooling	Natural convection					
Ambient Operation Temperature	-20°C...+60°C with no derating					
Ambient Storage Temperature	-40°C...+85°C					
EMC	EN55022 classB					
Safety conformity	EN60950-1, IEC60204-1					
Safety Class	I, VDE0805, VDE0100					
MTBF EN61709	500000h at 40°C and nominal load conditions					
MTTF IEC61709, SN29500	225116h (40°C/230Vac/75%)					
Humidity Under Operation	90% non condensing @ 25°C					
Climatic Class	3K3					
Pollution Rate	II A					
Altitude in Operation	3000m (9842 ft) above sea level					
Connector DC-In/outputs	Screw terminals 16-4AWG, 0.5-16mm ²					
Housing	IP20 IEC60529					
ROHS conformity	ROHS Directive 2011/65/EU					
REACH conformity	REACH Directive 1907/2006					
Connector Control Signals	D-SUB DB15S IEC807-2					
Connector 24V DC-supply	Screw Terminal Plug 3520037 (option)					
Dimensions (HxWxD)	124x65x96mm					
Net Weight	990g					

Key Features

Advantages of the UMS:

- no mechanical wear
- no electromagnetic influences
- no high-frequency distortions
- no acoustic distortions
- inured to high stress peaks
- no contact chatter
- extreme fast signal activation
- built in controller provides active monitoring of all operation status

Special features list:

- big screw terminals for up to 4AWG cabling
- featuring up to 120Vdc and 80A with a 320A surge current
- MOSFET outputs offer an extreme low RDS_{ON}

Parallel Operation

If you need more power – the UMS is designed to be connected in parallel

Manual and Technical Function

Description of Signals					
Model		T	T05V	TSF	TSF05V
Right Control Input	When a positive signal applies to the RIGHT control input. The (+) DC-Input will be connected to DC-Output1 and the (-) DC-Input will be connected to the DC-Output2. The control-LED RIGHT lights. Pin 9+11 are closed. The signal is galvanic isolated from the DC-Inputs and from the DC-outputs.	Yes	Yes	Yes	Yes
Left Control Input	When a positive signal applies to the LEFT control input. The (-) DC-Input will be connected to DC-Output1 and the (+) DC-Input will be connected to the DC-Output2. The control-LED LEFT lights. Pin 10+11 are closed. The signal is galvanic isolated from the DC-Inputs and from the DC-outputs.	Yes	Yes	Yes	Yes
Left & Right Input	When a positive signal applies to both the inputs LEFT & RIGHT at the same time or if alternatively no signal is emitted, the DC-Outputs are open and the Master-Stop-LED lights. The signal is galvanic isolated from the DC-Inputs and from the DC-outputs.	Yes	Yes	No	No
TSF Option: Left & Right Input	When a positive signal applies to both the inputs LEFT & RIGHT at the same time or if alternatively no signal is emitted, the DC-Outputs are short circuit and the Master-Stop-LED lights. At the same time the DC-outputs are also short circuit with the Minus-INPUT. The signal is galvanic isolated from the DC-Inputs and from the DC-outputs.	No	No	Yes	Yes
Master Stop Input	A positive signal must be emitted to the STOP input to run all functions of the UMS. The STOP input can also be used as an emergency stop. The DC-Outputs will be switched off either there is no signal emitted or it is 0V. Thus the Master-Stop-LED lights. The sense connections stay open until the Master Stop is released. The signal is galvanic isolated from the DC-Inputs and from the DC-outputs.	Yes	Yes	Yes	Yes
Sense Signal	When using the sense connections for a voltage drop compensation from the load lines the wires must be twisted pair to avoid emissions and interferences. The sense cables should be connected closed to the inputs of the load. It is recommended to use a 100uF bipolar capacitor in combination with a 100nF ceramic capacitor to avoid interferences to the control signal.	Yes	Yes	Yes	Yes
Monitor Signals	Max. 40Vdc / 200mA resistant. All signals are galvanic isolated from the DC-Inputs and from the DC-outputs.	Yes	Yes	Yes	Yes
Power LED	The Power LED glows when the 24Vdc supply applies to the DC-Power inputs at the bottom of the device	Yes	Yes	Yes	Yes

Connections Table

Connection	Signal	Remarks	
DC-Main Input (+)	DC(+) Input	See technical table on page 2	
DC-Main Input (-)	DC(+) Input		
DC-Main Output 1	DC-Output 1		
DC-Main Output 2	DC-Output 2		
Power Supply SK2	24Vdc (+)	The green LED glows when the power is on. We suggest to use the Camtec power supply LGR010.24 24Vdc 420mA for the UMS-models.	
Power Supply SK2	24Vdc (-)		
Sub-D Pin 1	Right input	Galvanic isolated $\leq 60Vdc$ from the DC-Inputs and the DC-Outputs	
Sub-D Pin 2	Left input		
Sub-D Pin 3	Stop input		
Sub-D Pin 4	GND PIN 1,2,3		
Sub-D Pin 5	Sense input (+)		
Sub-D Pin 6	Sense input (-)		
Sub-D Pin 7	Sense output (+)		
Sub-D Pin 8	Sense output (-)		
Sub-D Pin 9	Monitor right		Galvanic isolated $\leq 60Vdc$ from the DC-Inputs and the DC-Outputs Open collector
Sub-D Pin 10	Monitor left		
Sub-D Pin 11	GND PIN 9,10		
Sub-D Pin 12	not connected		
Sub-D Pin 13	not connected		
Sub-D Pin 14	not connected		
Sub-D Pin 15	not connected		

Signal Value Table Models T & TSF

Signal	Nominal	Min./Maximum	Response ON/ OFF	Galvanic isolated
Right	+24Vdc 5mA	+20-30Vdc 6mA	30ms / 4ms	+/- DC Input, PIN 1&2
Left	+24Vdc 5mA	+20-30Vdc 6mA	30ms / 4ms	+/- DC Input, PIN 1&2
Stop	+24Vdc 5mA	+20-30Vdc 6mA	30ms / 4ms	+/- DC Input, PIN 1&2
Monitor Right	+24Vdc 10mA	+40Vdc 200mA	30ms / 4ms	+/- DC Input, PIN 1&2
Monitor Left	+24Vdc 10mA	+40Vdc 200mA	30ms / 4ms	+/- DC Input, PIN 1&2

Signal Value Table Models T05V & TSF05V

Signal	Nominal	Min./Maximum	Response ON/ OFF	Galvanic isolated
Right	+5Vdc 1mA	+4,5-5,5Vdc 1mA	30ms / 4ms	+/- DC Input, PIN 1&2
Left	+5Vdc 1mA	+4,5-5,5Vdc 1mA	30ms / 4ms	+/- DC Input, PIN 1&2
Stop	+5Vdc 1mA	+4,5-5,5Vdc 1mA	30ms / 4ms	+/- DC Input, PIN 1&2
Monitor Right	+24Vdc 10mA	+40Vdc 200mA	30ms / 4ms	+/- DC Input, PIN 1&2
Monitor Left	+24Vdc 10mA	+40Vdc 200mA	30ms / 4ms	+/- DC Input, PIN 1&2

Signal Operation Table Models T & T05V

CTRL L	CTRL R	CTRL Stop	Mon L	Mon R	Sense Pin Connection	DC-Output (OUT) & Input (IN) Connection	LED L	LED R	LED STOP
0	0	1	OFF	OFF	ALL OPEN	ALL OPEN	OFF	OFF	ON
0	1	1	OFF	ON	5-7 / 6-8	MINUS-IN with OUT2 , PLUS-IN with OUT1	OFF	ON	OFF
1	0	1	ON	OFF	5-8 / 6-7	MINUS-IN with OUT1 , PLUS-IN with OUT2	ON	OFF	OFF
1	1	1	OFF	OFF	ALL OPEN	ALL OPEN	OFF	OFF	ON
x	x	0	OFF	OFF	ALL OPEN	ALL OPEN	OFF	OFF	ON

Signal Operation Table Models TSF & TSF05V

CTRL L	CTRL R	CTRL Stop	Mon L	Mon R	Sense Pin Connection	DC-Output (OUT) & Input (IN) Connection	LED L	LED R	LED STOP
0	0	1	OFF	OFF	ALL OPEN	MINUS-IN with OUT1 & OUT2 short circuited	OFF	OFF	ON
0	1	1	OFF	ON	5-7 / 6-8	MINUS-IN with OUT2 , PLUS-IN with OUT1	OFF	ON	OFF
1	0	1	ON	OFF	5-8 / 6-7	MINUS-IN with OUT1 , PLUS-IN with OUT2	ON	OFF	OFF
1	1	1	OFF	OFF	ALL OPEN	MINUS-IN with OUT1 & OUT2 short circuited	OFF	OFF	ON
x	x	0	OFF	OFF	ALL OPEN	ALL OPEN	OFF	OFF	ON

Application Notes

Overview

Many tasks formerly performed by electromagnetic relays can now be in solution Camtec new UMS electronic semiconductor relay. In comparison to a mechanic relay the UMS features no locomotive parts. The UMS Power Switch is a full semiconductor relay with built in controller. It is a 100% maintenance-free design. Under the same conditions a very good power relay is guaranteed to mostly feature around 10000 switch-loops before corrosion and aging pass to the device. The coil operating range provides earlier derating above 45°C. Our UMS works with no derating up to 60°C ambient temperature and provides unlimited switch-loops at full load.

Future-proof and flexible

The intelligent UMS executes different control and regulation feedings. Industrial control units open a wide field of applications to the power switch. For example new generation dc-drives increased standards are recommended. The testing of dc-drives works under extreme conditions and pre-set. Therefore special test units are the standard use. The UMS with its variable impedance matching offers the most suitable choice of demand.

Parallel Operation N+1 to increase power

If your demands exceed 320A surge current just connect some UMS in parallel. There is no external circuit recommended.

The control signals and the DC-Input and the Outputs of identical UMS modules can be parallel connected. From the control host a programme delay of 50ms is recommended for the Left/Right/Stop signal to ensure synchronous operation and balanced load sharing.

The monitoring outputs shall only be connected to one of the UMS modules. The cable section from the power supply to the UMS inputs must be of equal length and equal section. The same applies to the UMS outputs if they are parallel connected to the load. The use of star points or power bars can be helpful. Make sure that the sense is not connected. Connecting the sense lines while operating the UMS in parallel can cause trouble to the control circuit.

Power Crash Control (PCC)

The UMS features a special temperature and a voltage control so that in switch over mode (e.g. rotating direction changes) no shortcut occurs (Power Crash Control). The turn-over of the sense control works automatically. All control inputs and outputs are galvanic insulated by photo couplers.

Sample application:

Example:
UMS with Camtec programmable power supply unit on a DC-motor test bench.

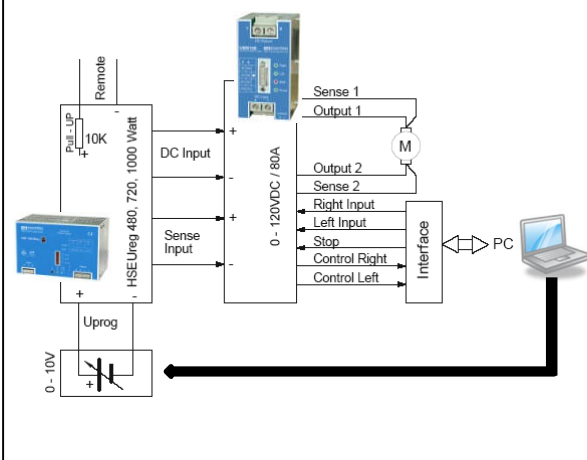

Applications

- DC motor drives
- valve control systems
- magnetic coil
- feeder control systems
- brake systems
- battery backup systems

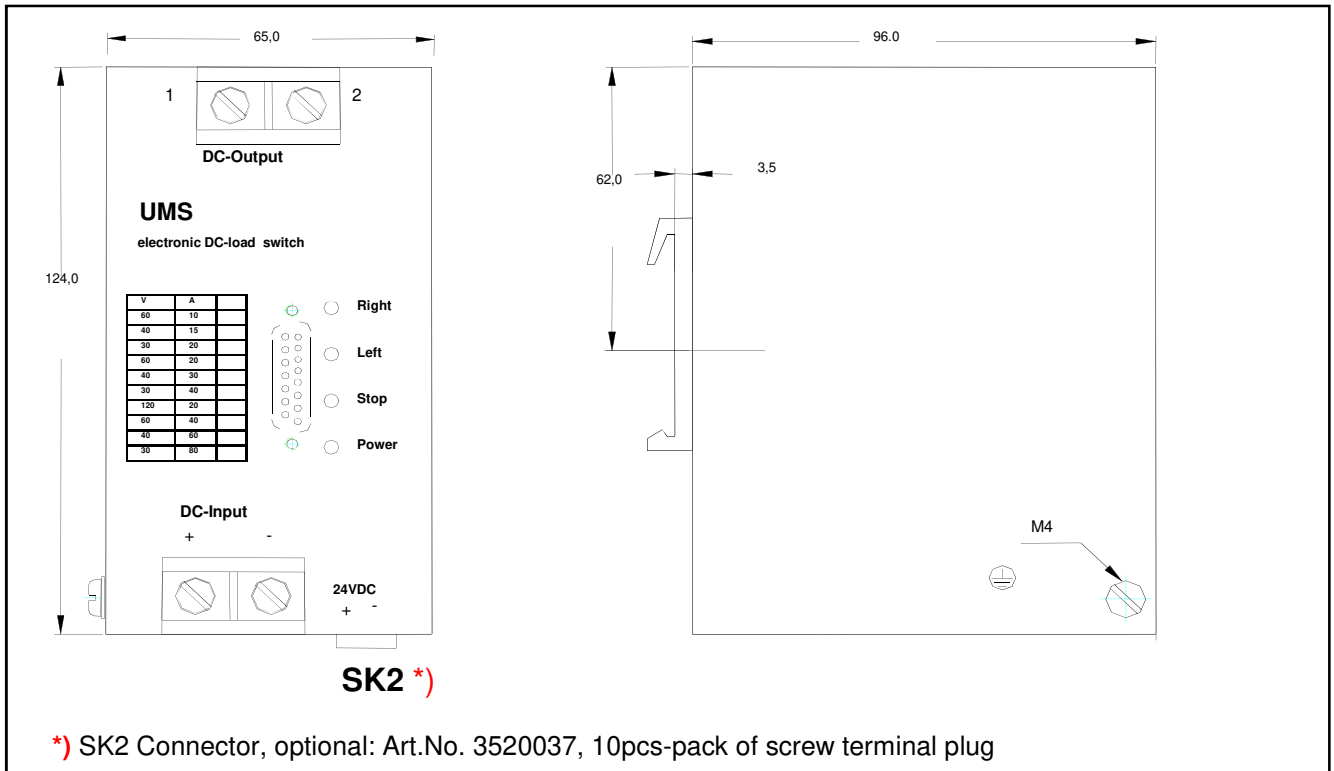

Mechanics

Stable metal/aluminium housing IP20. To allow adequate convection, a free air space of 50mm (top/bottom) and 5mm (sidewalls) is required; for active devices 15mm space from the sidewalls. For free air convection it is necessary to install the unit horizontal. Use the DIN-Rail installation (equiped standard) with the patented 35mm DIN-Rail brackets according to EN60275. It is easy to mount/dismount while snapping it onto the 35mm DIN-Rail - no tools are necessary.

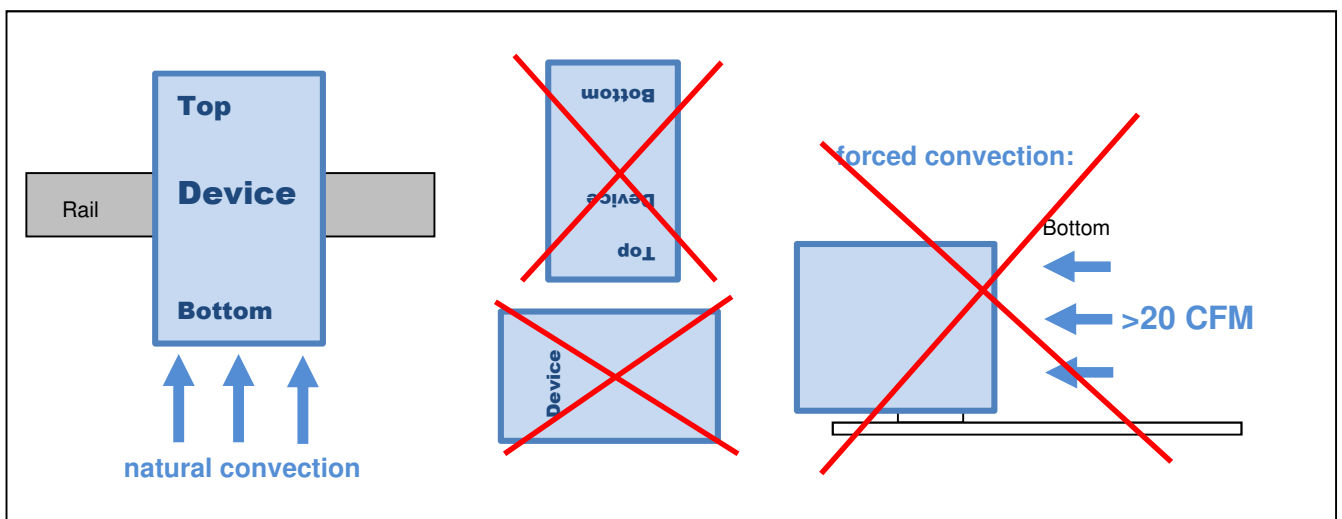

Mounting Instruction

Coating Option

We offer the UMS series with an optional coating. It is to be used in e.g. dusty, dirty, high humidity area or in awaiting quick temperature changes. Short circuit and corrosion at print board lines and at solder points can be prevented. The coat itself is a transparent acrylic resin.

Peters SL 1306 N-FLZ (transparent) IEC60216-1 2001, IPC-CC-830B, UL listed as permanent coating FileNo.: E80315 , UL94V-0

Ordering Information: add extension **C** to the model name (example): UMS00100.40TSF05V**C**

(Please note that the MOQ for below models with coating is 5pcs per lot)

Stock Numbers

Model	VDC/A	Power	Option	Ordering Article Number
UMS00025.20T	30V/20A	600W	-	3041040113CA
UMS00025.15T	40V/15A	600W	-	3041040112CA
UMS00025.10T	60V/10A	600W	-	3041040111CA
UMS00025.20T05V	30V/20A	600W	5V CTRL signal	3041040223CA
UMS00025.15T05V	40V/15A	600W	5V CTRL signal	3041040222CA
UMS00025.10T05V	60V/10A	600W	5V CTRL signal	3041040221CA
UMS00025.20TSF	30V/20A	600W	Motor Stop Function	3041040333CA
UMS00025.15TSF	40V/15A	600W	Motor Stop Function	3041040332CA
UMS00025.10TSF	60V/10A	600W	Motor Stop Function	3041040331CA
UMS00025.20TSF05V	30V/20A	600W	Motor Stop Function & 5V CTRL signal	3041040443CA
UMS00025.15TSF05V	40V/15A	600W	Motor Stop Function & 5V CTRL signal	3041040442CA
UMS00025.10TSF05V	60V/10A	600W	Motor Stop Function & 5V CTRL signal	3041040441CA
UMS00050.40T	30V/40A	1200W	-	3041040013CA
UMS00050.30T	40V/30A	1200W	-	3041040012CA
UMS00050.20T	60V/20A	1200W	-	3041040011CA
UMS00050.40T05V	30V/40A	1200W	5V CTRL signal	3041040213CA
UMS00050.30T05V	40V/30A	1200W	5V CTRL signal	3041040212CA
UMS00050.20T05V	60V/20A	1200W	5V CTRL signal	3041040211CA
UMS00050.40TSF	30V/40A	1200W	Motor Stop Function	3041040023CA
UMS00050.30TSF	40V/30A	1200W	Motor Stop Function	3041040022CA
UMS00050.20TSF	60V/20A	1200W	Motor Stop Function	3041040021CA
UMS00050.40TSF05V	30V/40A	1200W	Motor Stop Function & 5V CTRL signal	3041040413CA
UMS00050.30TSF05V	40V/30A	1200W	Motor Stop Function & 5V CTRL signal	3041040412CA
UMS00050.20TSF05V	60V/20A	1200W	Motor Stop Function & 5V CTRL signal	3041040411CA
UMS00100.80T	30V/80A	2400W	-	3041040001CA
UMS00100.60T	40V/60A	2400W	-	3041040002CA
UMS00100.40T	60V/40A	2400W	-	3041040003CA
UMS00100.20T	120V/20A	2400W	-	3041040004CA
UMS00100.80T05V	30V/80A	2400W	5V CTRL signal	3041040201CA
UMS00100.60T05V	40V/60A	2400W	5V CTRL signal	3041040202CA
UMS00100.40T05V	60V/40A	2400W	5V CTRL signal	3041040203CA
UMS00100.20T05V	120V/20A	2400W	5V CTRL signal	3041040204CA
UMS00100.80TSF	30V/80A	2400W	Motor Stop Function	3041040301CA
UMS00100.60TSF	40V/60A	2400W	Motor Stop Function	3041040302CA
UMS00100.40TSF	60V/40A	2400W	Motor Stop Function	3041040303CA
UMS00100.20TSF	120V/20A	2400W	Motor Stop Function	3041040304CA
UMS00100.80TSF05V	30V/80A	2400W	Motor Stop Function & 5V CTRL signal	3041040401CA
UMS00100.60TSF05V	40V/60A	2400W	Motor Stop Function & 5V CTRL signal	3041040402CA
UMS00100.40TSF05V	60V/40A	2400W	Motor Stop Function & 5V CTRL signal	3041040403CA
UMS00100.20TSF05V	120V/20A	2400W	Motor Stop Function & 5V CTRL signal	3041040404CA
SK2 Plug 10pcs/pack	-	-	For necessary external 24Vdc supply	3520037

Safety Instructions: Please read all warnings and advices carefully before installing or operating this device. Retain this operation manual always ready to hand. The device must be installed by specialist staff only.

Installation:

- 1.) The unit is designed for systems fulfilling the safety norms of dangerous voltages/energy and fire prevention
- 2.) Installation is restricted to specialists only, make sure that the DC wire system is free of voltage
- 3.) Opening the device, making any modifications to it, dismantling any screws from it, operating the item out of specification and/or using it in appropriate area will inevitably result in losing manufactureres guarantee; we decline taking any responsibility for risk of damages caused to someones health or to any installed system.

Warnings:

Disregard these warnings can cause fire, electric shock, serious accident and death.

1. **Never operate the device without Protective Earth Conductor.**
2. **Before connecting the item to the DC wire system make all wires free of voltage and assure accidently switch on.**
3. **Allow neat and professional cabeling.**
4. **Never open nor try to repair the device by yourself. Inside are dangerous voltages that can cause electric shock hazard.**
5. **Avoid metal pieces or other conductive material to fall into the item.**
6. **Do not operate the device under damp or wet conditions**
7. **It is prohibited to operate the unit under Ex conditions or in Ex-Area**



All parameters in the data sheet base on 15 minutes run-in @ full load / 25°C / 230Vac 50/60Hz, as otherwise stated.