

Features:

- 1U Design
- Programmable output Voltage (0% ~ 105%)
- Universal AC input / Full range
- Programmable output Current (0% ~ 105%)
(Refer to pg. 5 for connection diagram)
- Forced current sharing at parallel operation
- Constant current limit
- Selectable +5V / 0.5A or +9V / 0.3A auxiliary output
- Global control via RS232
- Remote setting multiple PSU via RS232, RS485 & I²C
- Power OK signal
- Remote ON / OFF, Remote sense function
- Protection: OVP, OLP, OTP, Fan failure
- Built-in active PFC Function



| MODEL | | PAE-800-12 | PAE-800-15 | PAE-800-24 | PAE-800-30 | PAE-800-36 | PAE-800-48 | PAE-800-60 | |
|--|--|---|---|------------|------------|------------|------------|------------|--|
| Output | DC Voltage Rated | 12V | 15V | 24V | 30V | 36V | 48V | 60V | |
| | Rated Current | 66.7A | 53.4A | 33.5A | 26.7A | 22.3A | 16.7A | 13.4A | |
| | Current Range | 0 ~ 66.7A | 0 ~ 53.4A | 0 ~ 33.5A | 0 ~ 26.7A | 0 ~ 22.3A | 0 ~ 16.7A | 0 ~ 13.4A | |
| | Rated Power | 800W | 800W | 800W | 800W | 800W | 800W | 800W | |
| | Ripple & Noise (Max.) | Note.2 120mVp-p | 150mVp-p | 240mVp-p | 300mVp-p | 360mVp-p | 480mVp-p | 600mVp-p | |
| | Voltage Adj. Range | ±5.0% Typical adjustment by potentiometer. (VR1) | | | | | | | |
| | Voltage Tolerance | Note.3 ±2.0% | (rated output voltage of single unit) | | | | | | |
| | Current Tolerance | ±3.0% (rated output current of single unit) | | | | | | | |
| | Line Regulation | ±1.0% | | | | | | | |
| | Load Regulation | ±1.0% | | | | | | | |
| Setup, Rise Time | 800ms, 100ms at full load | | | | | | | | |
| Hold Up Time (Typ.) | 8ms / 230VAC at full load | | | | | | | | |
| Input | Voltage Range | Note.4 90 ~ 264VAC, 127 ~ 370VDC | (Refer to de-rating curve) | | | | | | |
| | Frequency Range | 47 ~ 63Hz | | | | | | | |
| | Power Factor (Typ.) | 0.95 / 230VAC, 0.98 / 115VAC at full load | | | | | | | |
| | Efficiency (Max.) | 89% | 90% | 92% | 92% | 92% | 92% | 93% | |
| | AC Current (Max.) | 9.3A / 115VAC, 3.5A / 230VAC | | | | | | | |
| | Inrush Current (Typ.) | 30A / 115VAC, 60A / 230VAC | | | | | | | |
| Leakage Current | < 3.5mA / 240VAC | | | | | | | | |
| Protection | Over Load | 105% rated output power, Protection type: Constant current limit | | | | | | | |
| | Over Voltage | Variable OVP Refer to VCI VS OVP curve.(OVP Tolerance 7%) | | | | | | | |
| | Over Temperature | 85 ±5°C detect on NTC, Protection type: Auto recovery after temperature goes down | | | | | | | |
| Function | Auxiliary Power | Selectable +5V / 0.5A or +9V / 0.3A auxiliary output | | | | | | | |
| | Remote ON / OFF Control | By external switch | | | | | | | |
| | Power OK Signal | Open drain signal low when PSU turns on, Max. sink current: 20mA, Max. drain voltage: 40V. | | | | | | | |
| | Output Voltage Trim | Adjustment of output voltage is between 0 ~ 105% of rated output | | | | | | | |
| | Output Current Trim | Adjustment of output current is between 0 ~ 105% of rated output | | | | | | | |
| | Parallel (Current Sharing) | Note.5 | Please refer to page 5 | | | | | | |
| Environment | Address Setting | Up to 8 units can be set using an address switch (sw1), 0~7 | | | | | | | |
| | Working Temp. | -20 ~ +60°C (Refer to de-rating curve) | | | | | | | |
| | Working Humidity | 20 ~ 90% RH non-condensing | | | | | | | |
| | Storage Temp. & Humidity | -40 ~ +85°C, 10 ~ 95% RH | | | | | | | |
| | Temp. Coefficient | ±0.02% / °C (0 ~ 50°C) | | | | | | | |
| Safety & EMC | Vibration | 10 ~ 500Hz, 2G 10min. / 1cycle, period for 60min. each along X, Y, Z axes Compliance to IEC60068-2-6; IEC60068-2-64 | | | | | | | |
| | Safety Standards | Certified EN 62368-1; UL62368-1 | | | | | | | |
| | Withstand Voltage | Note.7 | I/P-O/P: 3KVAC (4242VDC), I/P-FG: 1.5KVAC (2121VDC), O/P-FG: 0.5KVAC (707VDC) | | | | | | |
| | Isolation Resistance | I/P-O/P, I/P-FG, O/P-FG: 100M Ohms / 500VDC (25°C / 70% RH) | | | | | | | |
| | EMI Conduction & Radiation | Certified EN 55032 | | | | | | | |
| Others | Power Harmonic & Voltage Fluctuation and Flicker | Certified EN 61000-3-2; EN 61000-3-3 | | | | | | | |
| | EMS Immunity | Note.6 | Certified EN 55024; IEC 61000-4-2,3,4,5,6,8,11 | | | | | | |
| Note | Cooling | Load and temperature control fan | | | | | | | |
| | Dimension (WxHxD) | 127x41x249 mm / 5.00x1.61x9.80 inch | | | | | | | |
| | Packing | 1.62kg; 9pcs / 17kg / 2.03CUFT | | | | | | | |
| <p>1. All parameters NOT specially mentioned are measured at 230VAC input, rated load and 25°C of ambient temperature.</p> <p>2. Ripple & noise are measured at 20MHz of bandwidth by using a 12" twisted pair-wire terminated with a 0.1uF & 47uF parallel capacitor.</p> <p>3. Tolerance: includes setup time tolerance, line regulation and load regulation.</p> <p>4. De-rating may apply in low input voltage. Please check the de-rating curve for more details.</p> <p>5. In parallel connection only one unit will operate if the total output load is less than 5% of the rated power.</p> <p>6. The power supply is considered a component which will be installed into a final equipment. The final equipment must be re-confirmed that it still meets EMC directives.</p> <p>7. This test is done without enclosure: I/P-O/P 4242VDC. If with enclosure: I/P-O/P 2121VDC, I/P-FG:2121VDC, O/P-FG: 707VDC</p> | | | | | | | | | |

Mechanical Drawings:

Unit:mm / inch

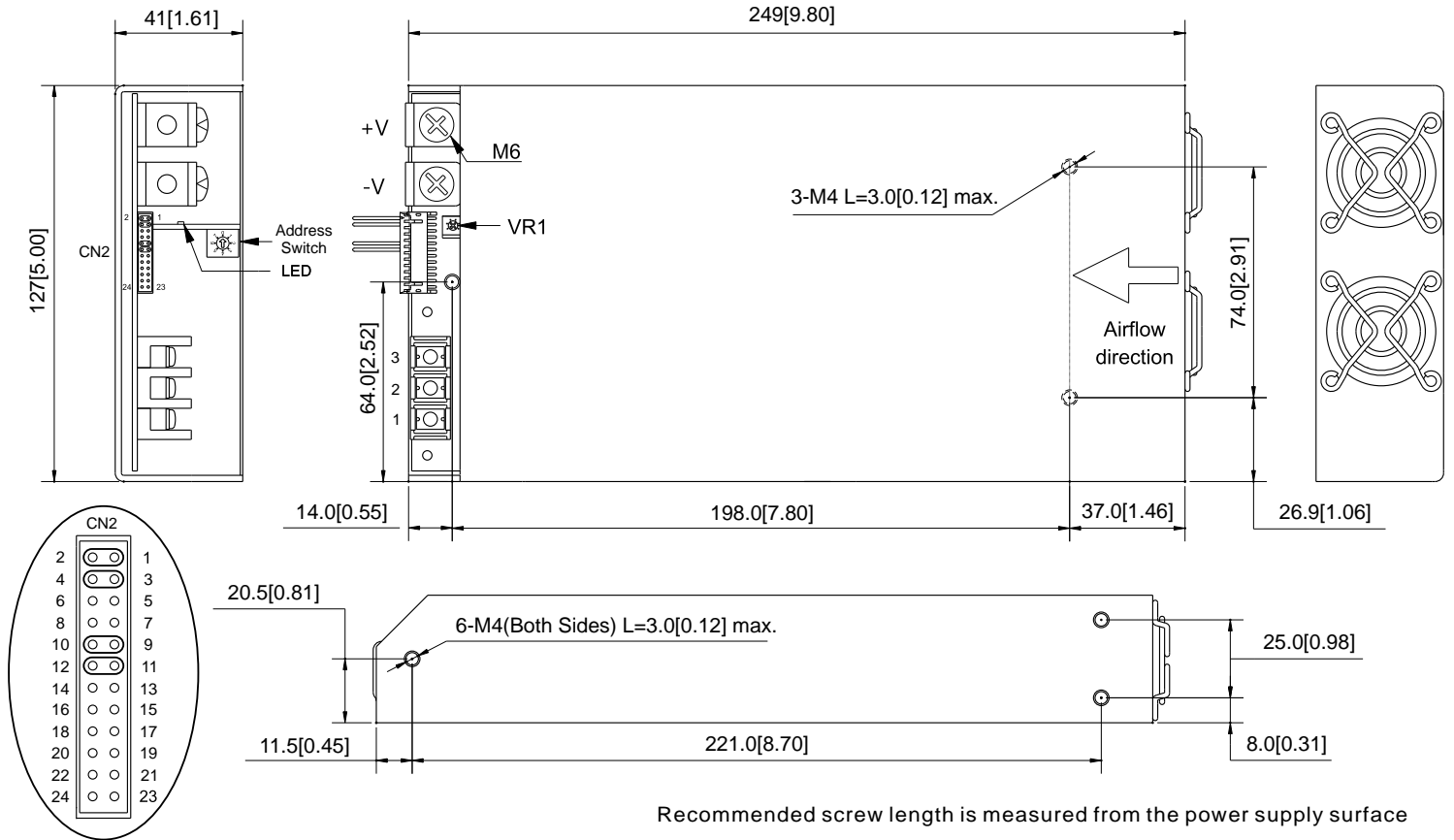

AC Input Terminal Pin No. Assignment

| Pin No. | Assignment |
|---------|------------|
| 1 | ACL |
| 2 | ACN |
| 3 | ⏏ |

CN2 Function Description:

| Pin No. | Function | Description | Pin No. | Function | Description | Mating Housing / Contact | |
|---------|----------|--|---------|----------|---|--------------------------------|-------------------------------------|
| 1 | VS+ | Remote sense (+) | 13 | ACI | I Program | JST PHDR-24VS or equivalent | JST SPHD-002T-P0.5 or equivalent |
| 2 | VO+ | Positive output voltage | 14 | GND | Ground | | |
| 3 | VS- | Remote sense (-) | 15 | VCI | V Program | | |
| 4 | VO- | Negative output voltage | 16 | GND | Ground | | |
| 5 | POK | Power OK | 17 | AUX | +5V / 0.5A or +9V / 0.3A Auxiliary power | | |
| 6 | GND | Ground | 18 | GND | Ground | | |
| 7 | PAR | Parallel operation current share | 19 | SCL | Serial Clock used in the I ² C interface | | |
| 8 | VSET | Aux output setting | 20 | SDA | Serial Data used in the I ² C interface | | |
| 9 | EN- | Inhibit ON/OFF (-) | 21 | AUX | +5V / 0.5A or +9V / 0.3A Auxiliary power | | |
| 10 | GND | Ground | 22 | GND | Ground | | |
| 11 | EN+ | Inhibit ON/OFF (+) | 23 | RX | For RS232 Receiver function | | |
| 12 | AUX | +5V / 0.5A or +9V / 0.3A Auxiliary power | 24 | TX | For RS232 Transmission function | | |

LED Status:

| LED | LED Signal | Status |
|-------------------------|------------|-------------------------------------|
| Solid(Green) | | Power OK (Local mode) |
| Solid(Orange) | | Power OK (Remote mode) |
| Slow Blink(Green) | | Power Standby |
| Fast Blink(Red) | | Over Voltage Protection (OVP) |
| Solid(Red) | | Over Load Protection (OLP) |
| Slow Blink(Red) | | Over Temperature Protection (OTP) |
| Intermittent Blink(Red) | | Fan Failure |
| Interface Blink(Red) | | Power Failure |

*Local mode : Use ACI/VCI to control output current and voltage.
Remote mode : Use RS-232 or I²C command to control output current and voltage.

De-rating Curve:

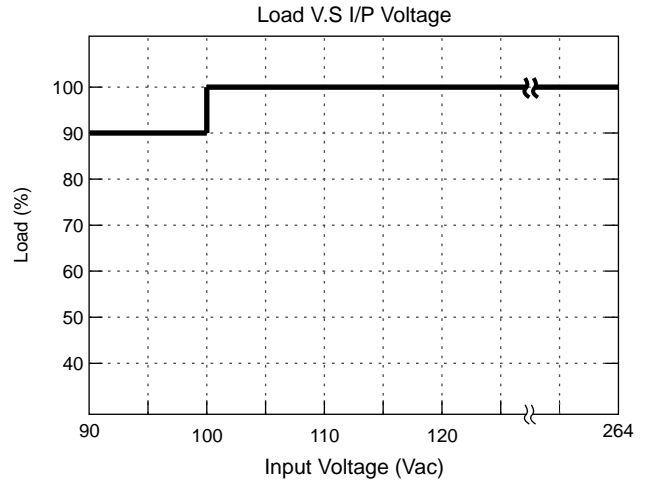
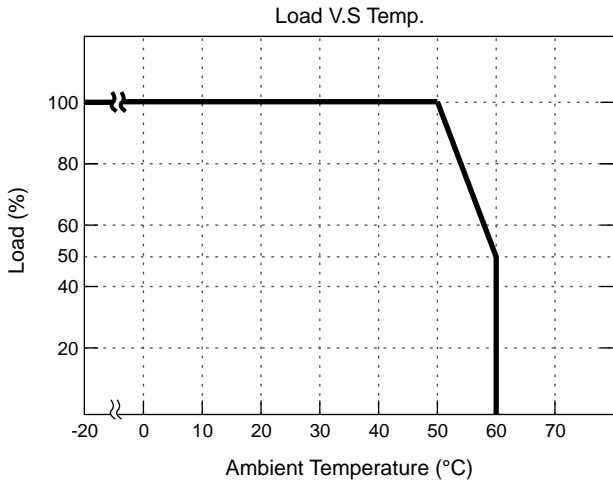

CMD VS Output Curve:

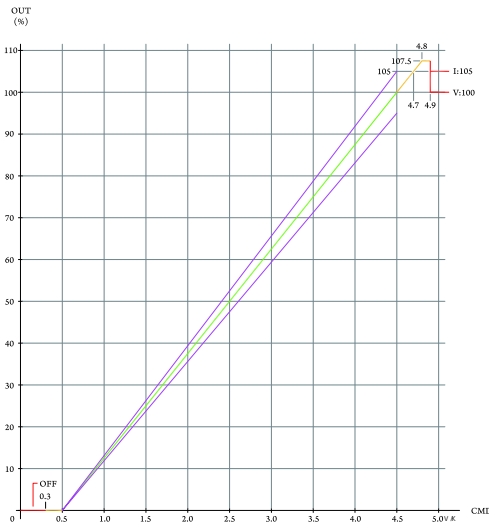

VCI VS OVP Curve:

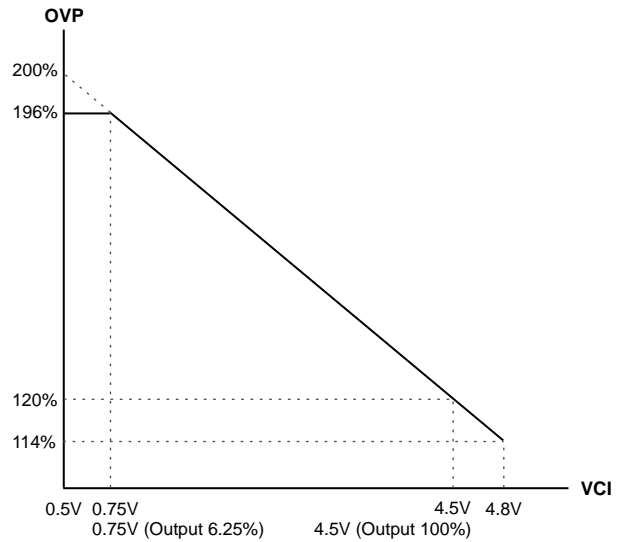

To ensure the power supply output voltage and current could be accurately adjusted, please make sure to adjust the output voltage and current > 10% vs. the rated voltage and current. (e.g. for a 24V unit, please adjust the DC output voltage above 2.4V to ensure accuracy; same applies to the output current)

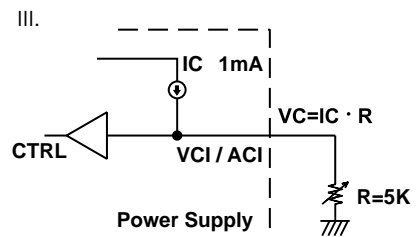
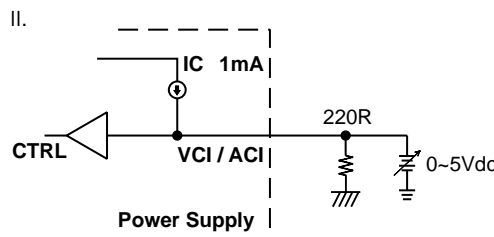
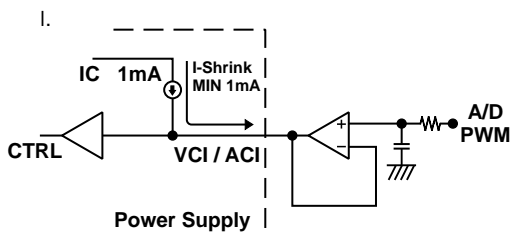
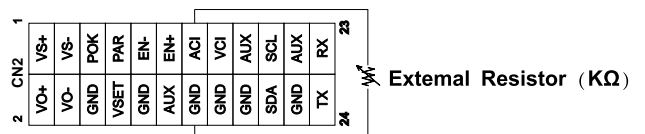
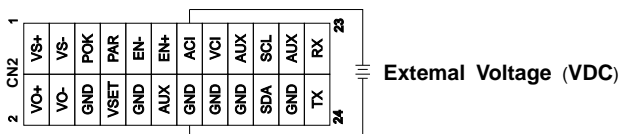

Remote ON/OFF:

(A) Default Setting

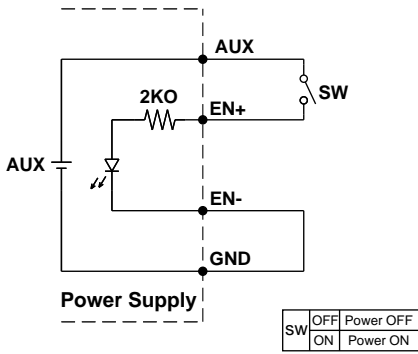

(A) Using internal 5V auxiliary source

(B)

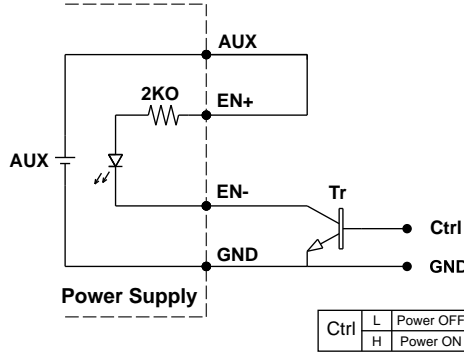

(B) ON / OFF Control by NPN transistor

(C)

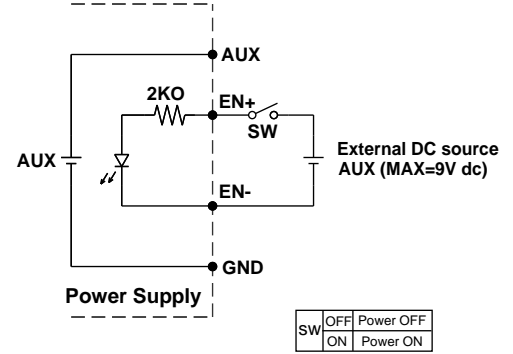

(C) Using external voltage source

Power OK Signal:

*The grounding of "AUX" power should be connected to "GND" port. If "V-" is connected as Grounding, make sure to short the GND and V- ports.

*Place an additional capacitor to have a better performance of auxiliary power operation.

| | | |
|------|-----------------------|----|
| VSET | Open(Default Setting) | 5V |
| | Short To GND | 9V |

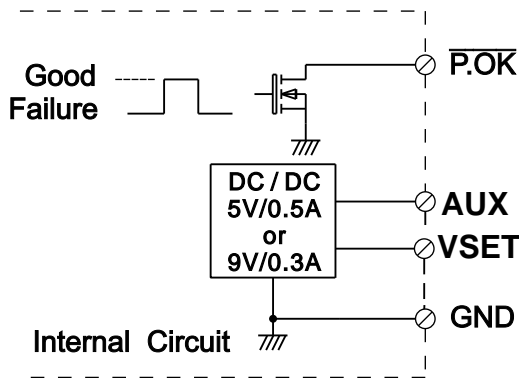

AUX and P.O.K Signal

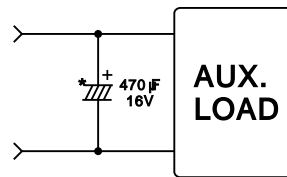

1. Remote Sense

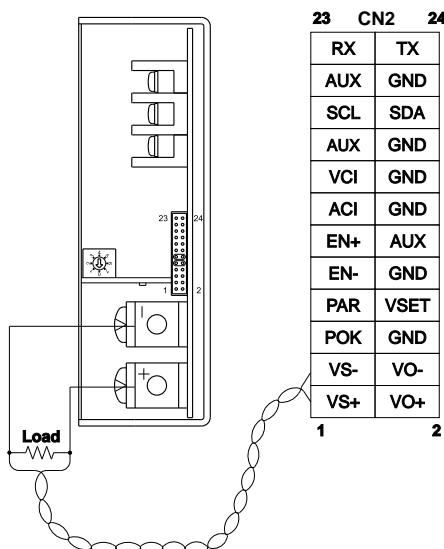

2. Local Sense (Default setting)

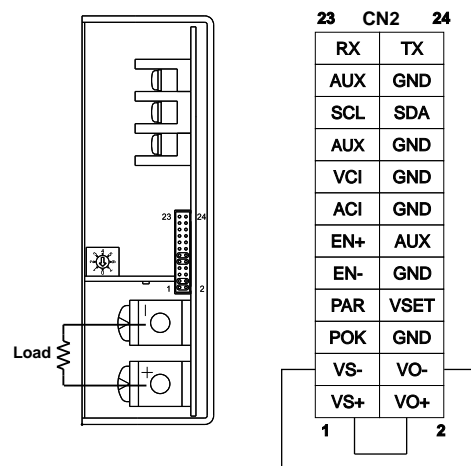

VS-,VS+ Compensation Voltage < 0.5V

3. Current Sharing with Remote Sensing(Parallel Connection)

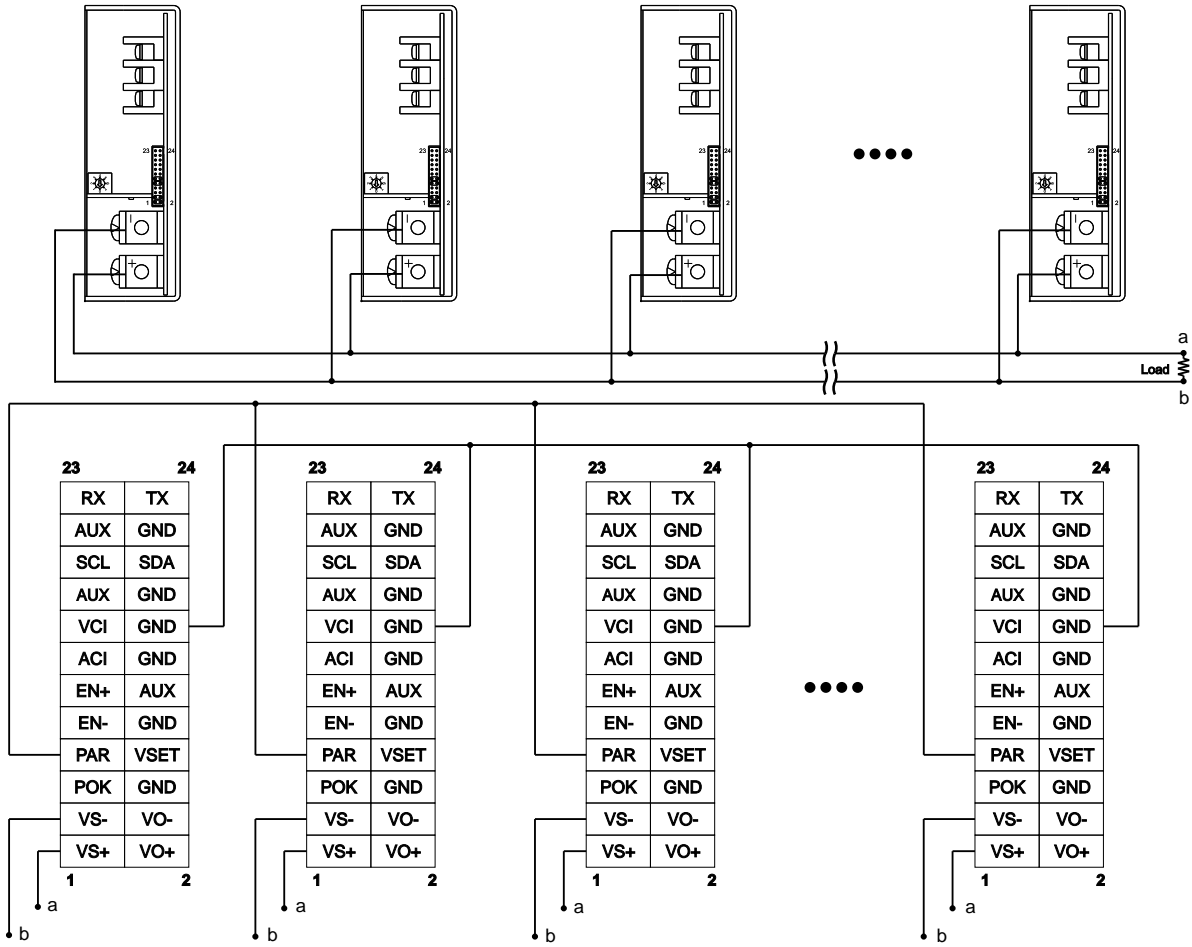

Please connect PAR pins together for current sharing function

4. Current Sharing with Local Sensing

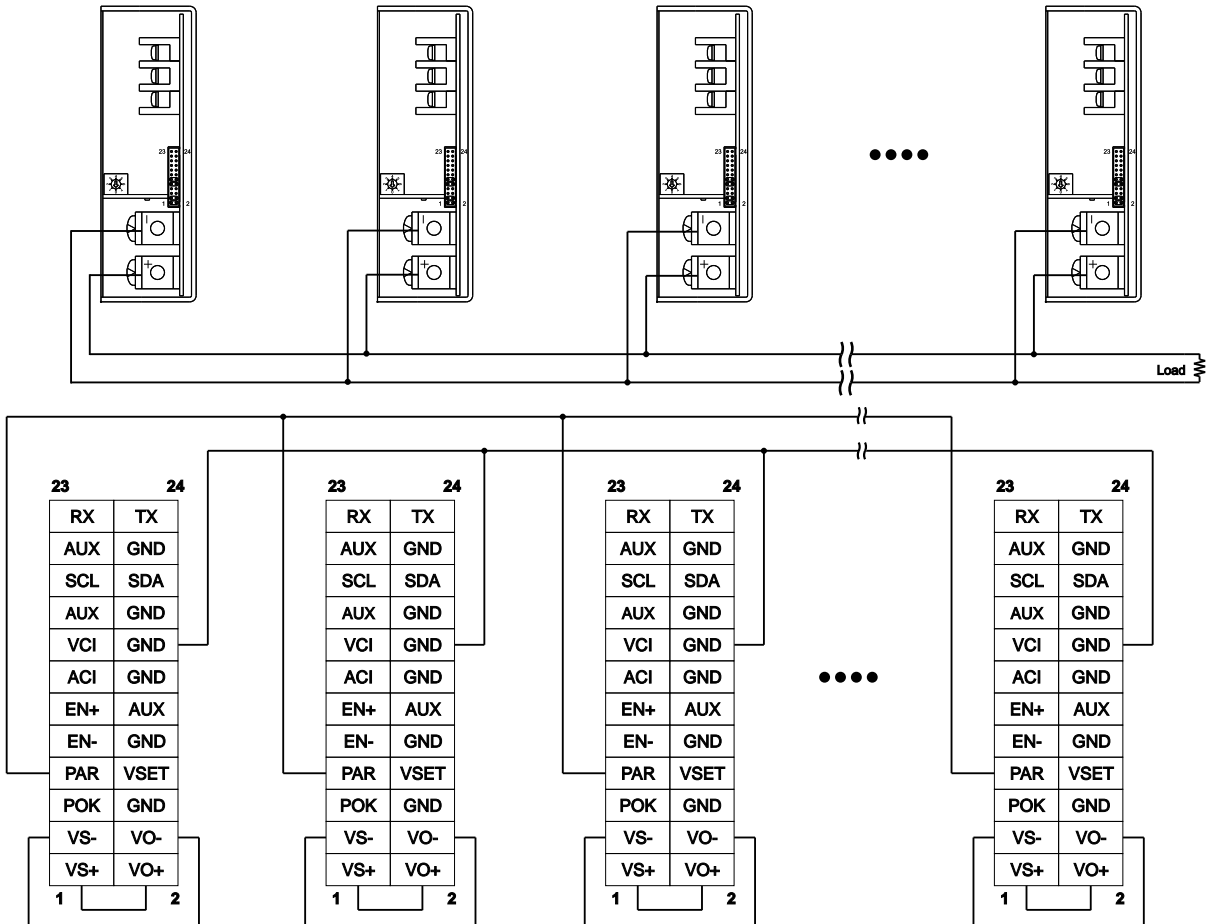

Please connect PAR pins together for current sharing function

Installation Instruction:

1. Mounting Directions

1-1 Recommended standard mounting methods :

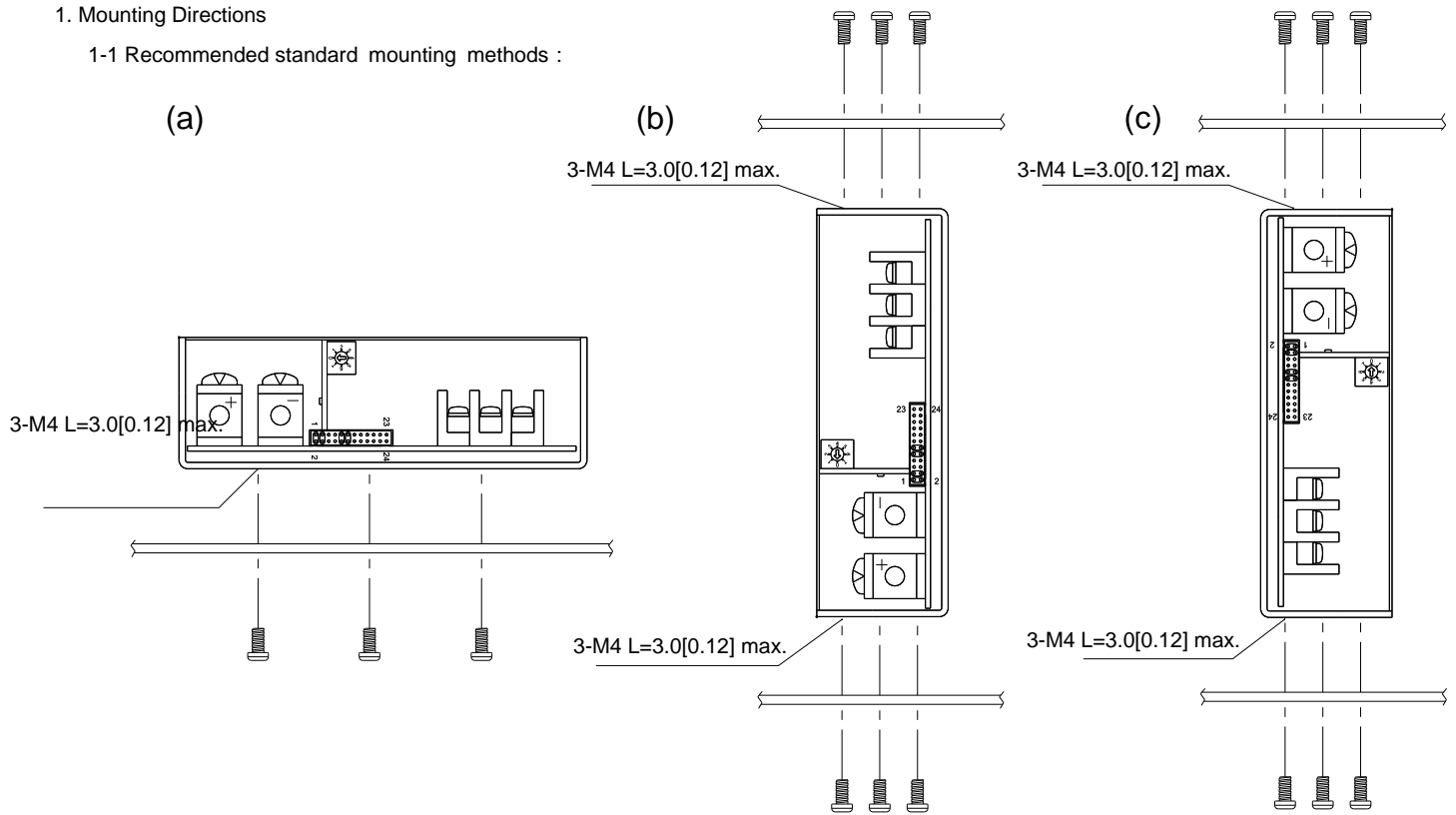

Recommended screw length is measured from the power supply surface

2. Mounting Method

2-1 There are ventilating holes on the front and back side panels, do not obstruct; allow 50mm at least for air flow.

2-2 Recommended the torque of mounting screw:
M4 screw: 1.27N · m (13.0kgf · cm)

