

## DC/DC Converter

## TEQ 40WIR Series, 40 Watt

- High power block with excellent thermal convection
- Operating temperature -40°C to +92°C
- Ultra wide 4:1 input voltage range
- EN 50155 approval for railway applications
- Excellent efficiency up to 91%
- Input filter meet EN 55032 class B
- I/O isolation up to 3000 VDC
- Under voltage lock-out circuit
- Protection against overvoltage, over-temperature and short circuit
- Output LED indicator



The TEQ-40WIR Series is a family of isolated high performance dc-dc converter modules with ultra-wide 4:1 input voltage ranges which come in a rugged metal case. These converters are suitable for a wide range of applications, but the product is designed particularly also for industrial applications where often no PCB mounting is possible but the module has to be mounted on a chassis. A very high efficiency and the heatsink construction allows an operating temperature up to +83°C with natural convection cooling without power derating and up to +92°C with power derating. Further features include under voltage lockout, over temperature protection and short circuit protection.

Models				
Order code	Input voltage	Output voltage	Output current max.	Efficiency typ.
TEQ 40-2411WIR	<b>9.5 - 36 VDC</b> (nominal 24 VDC)	5 VDC	8.0 A	90 %
TEQ 40-2412WIR		12 VDC	3.33 A	91 %
TEQ 40-2413WIR		15 VDC	2.67 A	91 %
TEQ 40-2415WIR		24 VDC	1.67 A	90 %
TEQ 40-4811WIR	<b>18 - 75 VDC</b> (nominal 48 VDC)	5 VDC	8.0 A	90 %
TEQ 40-4812WIR		12 VDC	3.33 A	91 %
TEQ 40-4813WIR		15 VDC	2.67 A	91 %
TEQ 40-4815WIR		24 VDC	1.67 A	90 %
TEQ 40-7211WIR	<b>43 - 160 VDC</b> (nominal 110 VDC)	5 VDC	8.0 A	88 %
TEQ 40-7212WIR		12 VDC	3.33 A	89.5 %
TEQ 40-7213WIR		15 VDC	2.67 A	90 %
TEQ 40-7215WIR		24 VDC	1.67 A	89 %

## Input Specifications

Input current no load	24 Vin models: 19 mA typ. 48 Vin models: 14 mA typ. 110 Vin models: 10 mA typ.
Surge voltage (1 s max.)	24 Vin models: 50 VDC max 48 Vin models: 100 VDC max. 110 Vin models: 170 VDC max.
Start-up voltage	24 Vin models: 9.5 VDC (or lower) 48 Vin models: 18 VDC (or lower) 110 Vin models: 43 VDC (or lower)
Under voltage shut down	24 Vin models: 8 VDC typ. 48 Vin models: 16 VDC typ 110 Vin models: 40 VDC typ.
Inrush current	15 A typ.
Input fuse	24 Vin models: 8 A (fast acting) 48 Vin models: 4 A (slow blow) 110 Vin models: 2 A (slow blow)
EMC emissions	– Conducted and radiated input suppression EN 55032 class B (internal filter)
EMC immunity	– Electrostatic discharge ESD EN 61000-4-2, air $\pm 8$ kV, contact $\pm 6$ kV, perf. criteria A – Radiated immunity EN 61000-4-3, 20 V/m, perf. criteria A – Fast transient EN 61000-4-4, $\pm 2$ kV, perf. criteria A – Surge EN 61000-4-5, $\pm 1$ kV perf. criteria A – Conducted immunity EN 61000-4-6, 10 Vrms, perf. criteria A – Magnetic field immunity EN 61000-4-8, 100 A/m, perf. criteria A

## Output Specifications

Voltage set accuracy	$\pm 1$ %
Regulation	– Input variation (Vin min. to Vin max.) – Load variation (0 to 100 %) 5 Vout models: 0.5 % max. 1.5 % max. other models: 1.0% max.
Temperature coefficient	$\pm 0.02$ %/K typ.
Start up time (constant resistive load)	100 ms typ.
Hold up time	10 ms min. (acc. EN50155 class S2)
Minimum load	not required
Ripple and noise (20 MHz Bandwidth)	5 Vout models: 75 mVp-p max. 12 & 15 Vout models: 100 mVp-p max. 24 Vout models: 150 mVp-p max.
Transient response (25% load step change)	250 $\mu$ s typ.
Over voltage protection	5 Vout models: at 6.2 VDC typ. 12 Vout models: at 15 VDC typ. 15 Vout models: at 20 VDC typ. 24 Vout models: at 30 VDC typ.
Output indicator	green LED
Current limitation	at 150 % of rated lout max., hiccup mode
Short circuit protection	continuous, automatic recovery
Capacitive load	5 Vout models: 20'000 $\mu$ F 12 Vout models: 3'900 $\mu$ F 15 Vout models: 2'600 $\mu$ F 24 Vout models: 1'300 $\mu$ F

All specifications valid at nominal input voltage, full load and +25°C after warm-up time unless otherwise stated.

## General Specifications

Temperature ranges	– Operating (natural convection: 20 LFM, 0.1 m/s) – Storage temperature	–40°C to +83°C (without derating) –40°C to +92°C (with derating) –40°C to +105°C
Derating	– Natural convection – Natural convection, with 2U base plate*	5.0 %/K above 80°C (depending on model) 6.7 %/K above 85°C (depending on model)
Over temperature protection		at 115°C typ.
Mechanical shock		acc. EN61373, MIL-STD-810F
Thermal shock		acc. MIL-STD-810F
Vibration		acc. EN61373, MIL-STD-810F
Humidity (non condensing)		5 – 95 % rel H max.
Isolation voltage (60 s)	– Input/Output to Case – Input to Output	1'600 VDC 110 Vin models: 3'000 VDC other models: 1'600 VDC
Isolation capacitance (input/output)		5'000 pF typ.
Isolation resistance (input/output)		>1 GOhm
Reliability, calculated MTBF (MIL-HDBK-217F at +25°C, ground benign)		1'000'000 h
Switching frequency		225 – 275 kHz (PWM)
Safety standards & approvals	– CB test certificate – UL online certification E188913, OQG02 – Railway immunity	IEC/EN 60950-1 UL 60950-1 EN 50155
Environmental compliance	– Reach – RoHS – Flamability identified acc. EN 45545-2	RoHS directive 2011/65/EU

## Physical Specifications

Casing material	aluminium
Package weight	129 g (4.55 oz)

\* The 2U iron base-plate dimension is 19" x 3.5" x 0.063" (48.26 × 8.89 × 0.16 mm)

**Outline Dimensions**

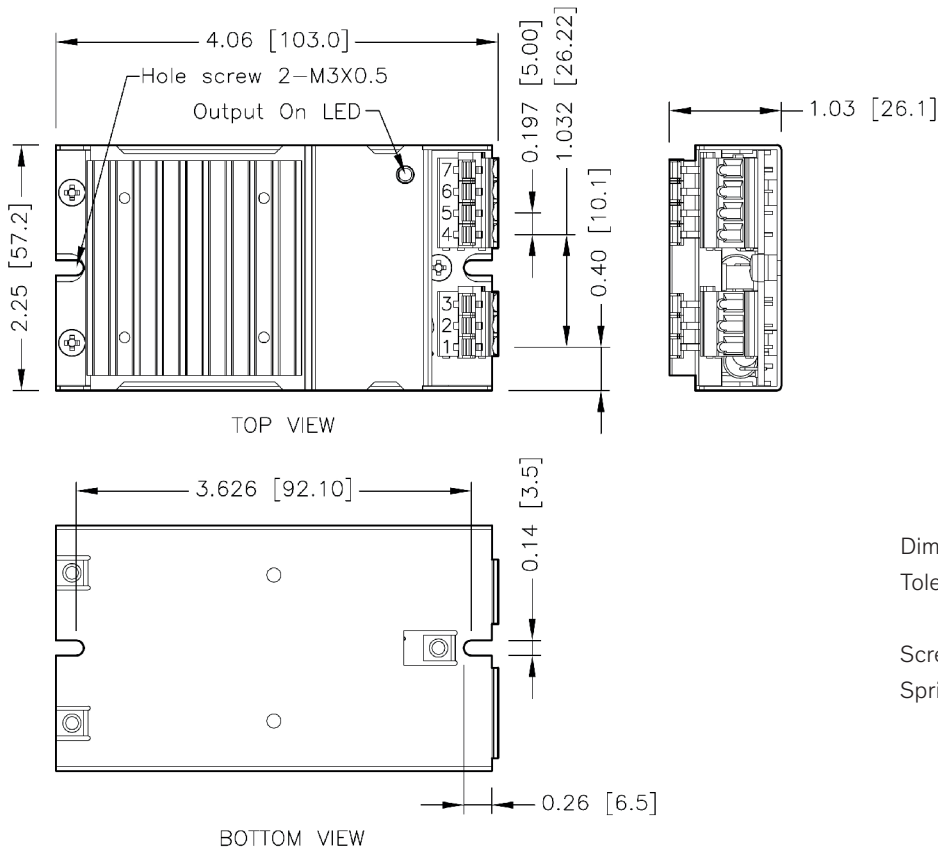

**Terminal connection**

Terminal	
1	+Vin
2	-Vin (GND)
3	NC
4	NC
5	-Vout
6	+Vout
7	NC

Dimensions in Inch [mm]

Tolerances: x.x ±0.02 [±0.5]

x.xx ±0.01 [±0.25]

Screw max. torque: 5.0 kgf - cm (0.49 Nm)

Spring terminals: 12 - 18 AWG