

- Fully encapsulated power supplies in plastic casing for PCB mount
- Fully regulated outputs
- 4242 VDC I/O-isolation
- High efficiency up to 90%
- Universal input range 90 to 264 VAC
- Operating temperature range: -40°C to +70°C max.
- Safety class II prepared
- Short circuit, over power and over voltage protection



TMG Series AC/DC power modules come in fully encapsulated plastic package. They are ultra-compact, energy-efficient and cost/performance optimised for prevailing market requirements. The high efficiency and the use of high grade components make these modules suitable for an operating temperature range of -40°C to +70°C. Together with very low no-load power consumption they are suitable for applications conforming with the ErP directive. The modules are protected against short-circuit and over voltage. EMI/EMC characteristics and the safety approval package qualify them for demanding applications in equipment for industrial or commercial environments.

Models				
Order Code	Output Power (max.)	Output Voltage (nom.)	Output Current (max.)	Efficiency (typ.)
TMG 07105	6.3 W	5.0 VDC	1260 mA	77 %
TMG 07112	7 W	12 VDC	583 mA	80 %
TMG 07115	7 W	15 VDC	466 mA	80 %
TMG 07124	7 W	24 VDC	292 mA	80 %
TMG 15105	13.5 W	5.0 VDC	2700 mA	80 %
TMG 15112	15 W	12 VDC	1250 mA	84 %
TMG 15115	15 W	15 VDC	1000 mA	84 %
TMG 15124	15 W	24 VDC	625 mA	85 %
TMG 30103	16.5 W	3.3 VDC	5000 mA	80 %
TMG 30105	25 W	5.0 VDC	5000 mA	84 %
TMG 30112	30 W	12 VDC	2500 mA	89 %
TMG 30115	30 W	15 VDC	2000 mA	86 %
TMG 30124	30 W	24 VDC	1250 mA	86 %
TMG 50105	40 W	5.0 VDC	8000 mA	86 %
TMG 50112	50 W	12 VDC	4167 mA	90 %
TMG 50115	50 W	15 VDC	3333 mA	87 %
TMG 50124	50 W	24 VDC	2083 mA	88 %
TMG 50148	50 W	48 VDC	1040 mA	89 %

Input Specifications

Input voltage	– AC Input	30 W model: 90 – 305 VAC (47 – 63 Hz) other models: 90 – 264 VAC (47 – 63 Hz) all models: derating of 2%/V below 100 VAC required
	– DC Input	120 – 370 VDC (DC+: N / DC–: L)
Leakage current		< 0.25 mA (at <240 VAC)
Inrush current*		7 W models: 20/40 A max. (115/230 VAC) 15 W models: 25/45 A max. (115/230 VAC) 30 W models: 30/60 A max. (115/230 VAC) 50 W models: 40/60 A max. (115/230 VAC)
No-load power consumption		< 0.3 W
External input fuse (required)		7 & 15 W models: 2.0 A slow blow type 30 & 50 W models: 3.15 A slow blow type

Output Specifications

Voltage accuracy		± 2 % max.
Regulation	– Input variation	0.5 % max.
	– Load variation (10–100 %)	7 & 15 W models: 1.0 % max.
	– Load variation (0–100 %)	30 & 50 W models: 1.0 % max.
Minimum load		not required
Hold-up time	7 W models:	30 ms min. (230 VAC)
	15 W models:	35 ms min. (230 VAC)
	30 W models:	10 ms min. (230 VAC)
	50 W models:	10 ms min. (230 VAC)
Ripple and Noise (20MHz bandwidth) (measured with 0.1µF & 47µF parallel capacitor)	5 VDC models:	120 mVp-p max.
	other models:	1 % of Vout max.
Over power protection	7 W models: 134 – 203% of rated output power 15 W models: 164 – 228% of rated output power 30 W models: 172 – 268% of rated output power 50 W models: 200 – 258% of rated output power	
Short circuit protection		hiccup, indefinite, auto recovery
Overvoltage protection	15, 30 & 50 W models:	by Zener diode

Max. capacitive load [µF]	3.3 VDC	5.0 VDC	12 VDC	15 VDC	24 VDC	48 VDC
TMG 07	–	3'300	1'000	470	68	–
TMG 15	–	7'000	1'500	1'000	470	–
TMG 30	6'800	6'800	1'600	1'200	470	–
TMG 50	–	10'000	3'500	3'000	2'200	330

General Specifications

Temperature ranges	– operational (natural convection 20 LFM)	–40°C to +70°C max.
	– Storage temperature	–40°C to +85°C max.
Power derating		see derating graphs on page 3
Temperature coefficient		0.02 %/K
Cooling		natural convection, no internal fan
Altitude during operation	7 & 15 W models:	3000 m max.
	30 & 50 W models:	2000 m max.
Switching frequency (at 230 VAC)	7 W models:	60 kHz – 140 kHz
	15 W models:	40 kHz – 140 kHz
	30 W models:	40 kHz – 73 kHz
	50 W models:	60 kHz – 70 kHz

* For the 7 & 15 W models an external Thermistor has to be integrated in the circuit at the converter input L (in series).
Thermistor recommendation: 10R / 15z

Ambient Temperature [°C]

General Specifications (continued)

Humidity (non condensing)		95 % rel. H max.
Isolation	– Input/Output	15 W models: 5656 VDC other models: 4242 VDC
MTBF (MIL-HDBK-217F, at 25 °C ground benign)		7 W models: > 500'000 h 15 W models: > 450'000 h 30 W models: > 400'000 h 50 W models: > 300'000 h
Protection class		class II prepared
Safety standards		IEC/EN 60950-1 UL 60950-1

Electromagnetic compatibility (EMC), Emissions

– Conducted/Radiated RI suppression on input	EN 55032 class B
--	------------------

Electromagnetic compatibility (EMC), Immunity

– Electrostatic discharge (ESD)	EN 55024		
– Radiated RF field immunity	IEC/EN 61000-4-2	4 kV / 8 kV	criteria A
– Electrical fast transient / burst immunity	IEC/EN 61000-4-3	10V/m	criteria A
– Surge immunity*	IEC/EN 61000-4-4	2 kV	criteria A
– Immunity to conducted RF disturbances	IEC/EN 61000-4-5	1 kV	criteria A
– Magnetic field immunity	IEC/EN 61000-4-6	10V	criteria A
– Mains voltage dips and interruptions	IEC/EN 61000-4-8	30 A/m	criteria A
	IEC/EN 61000-4-11	30% / 500ms	criteria A

Case material

plastic (UL94V-0 rated)

Environmental compliance

– Reach
– RoHS

RoHS directive 2011/65/EU

* For the 7 & 15 W models an external Varistor has to be integrated in the circuit at the converter input (in parallel). Recommendation: 14S471K

TMG 07:

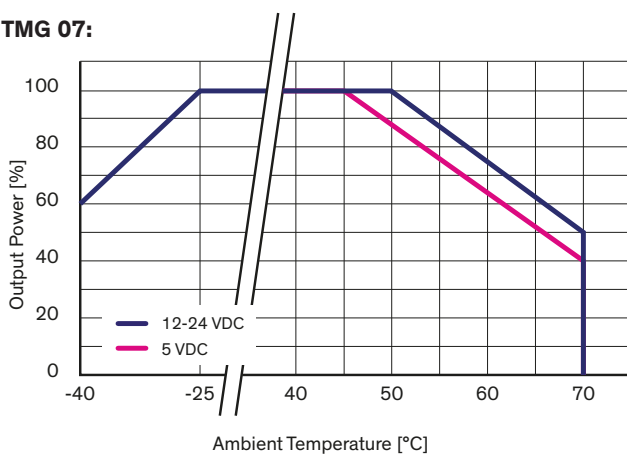

TMG 15:

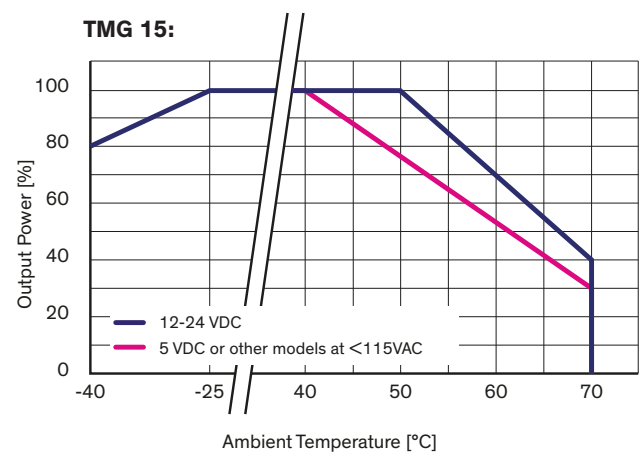

TMG 30:

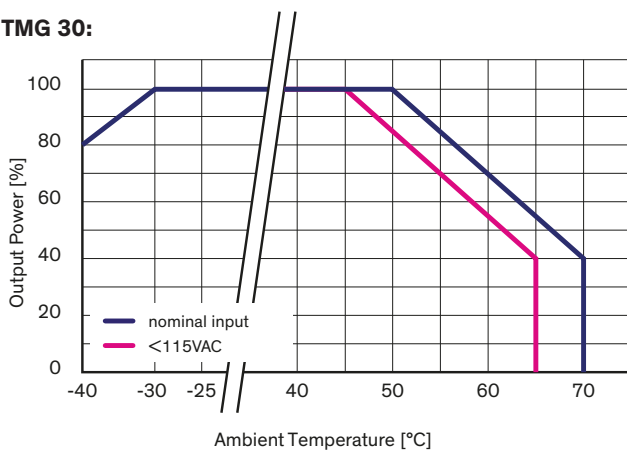

TMG 50:

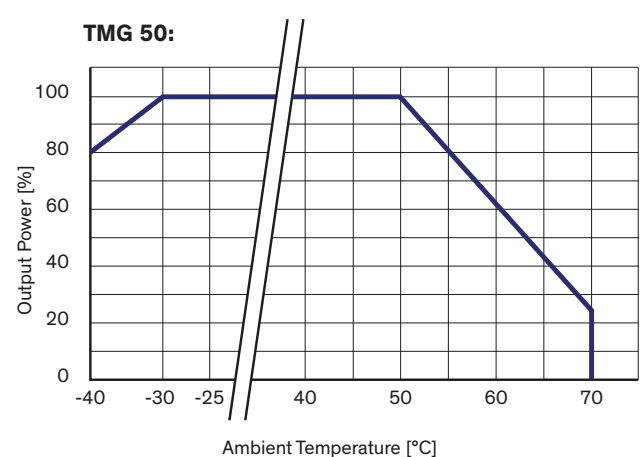

Outline Dimensions

TMG 07 xxx:

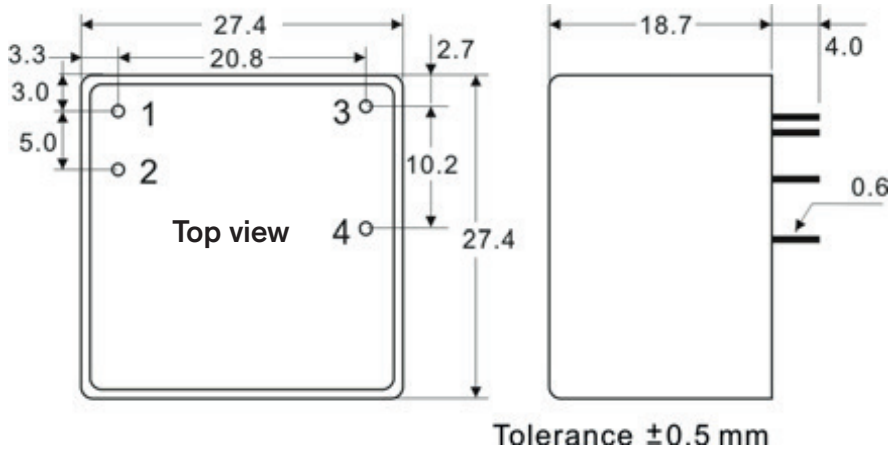

Pinout	
Pin	Single
1	AC IN (N)
2	AC IN (L)
3	+Vout
4	-Vout

Weight: 26 g (0.92 oz)

TMG 15 xxx:

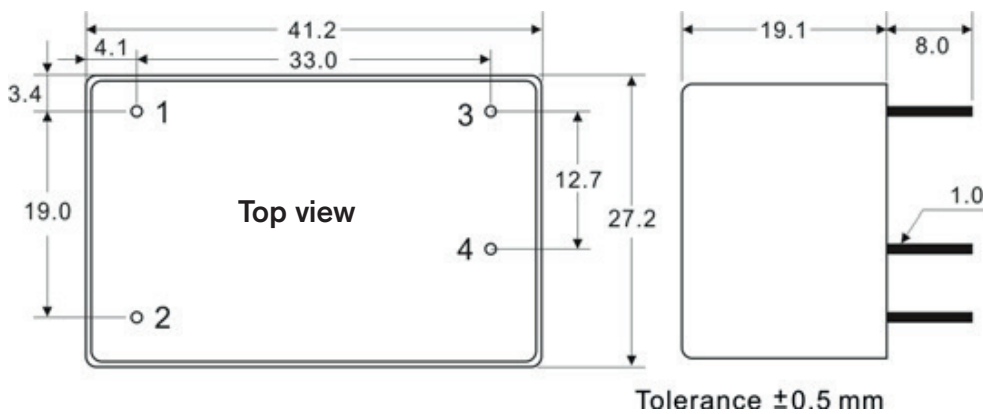

Pinout	
Pin	Single
1	AC IN (L)
2	AC IN (N)
3	-Vout
4	+Vout

Weight: 47 g (1.66 oz)

Dimensions in [mm]
Tolerances: ± 0.5 mm
Pin tolerances: ± 0.1 mm

Ambient Temperature [°C]

Outline Dimensions (continued)

TMG 30 xxx:

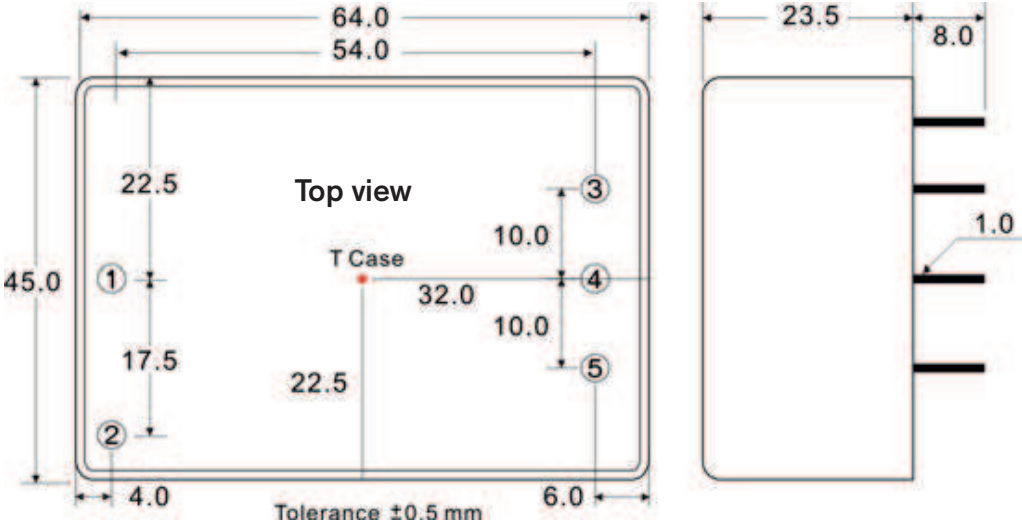

Pinout	
Pin	Single
1	AC IN (N)
2	AC IN (L)
3	-Vout
4	No Pin
5	+Vout

Weight: 130 g (4.59 oz)

TMG 50 xxx:

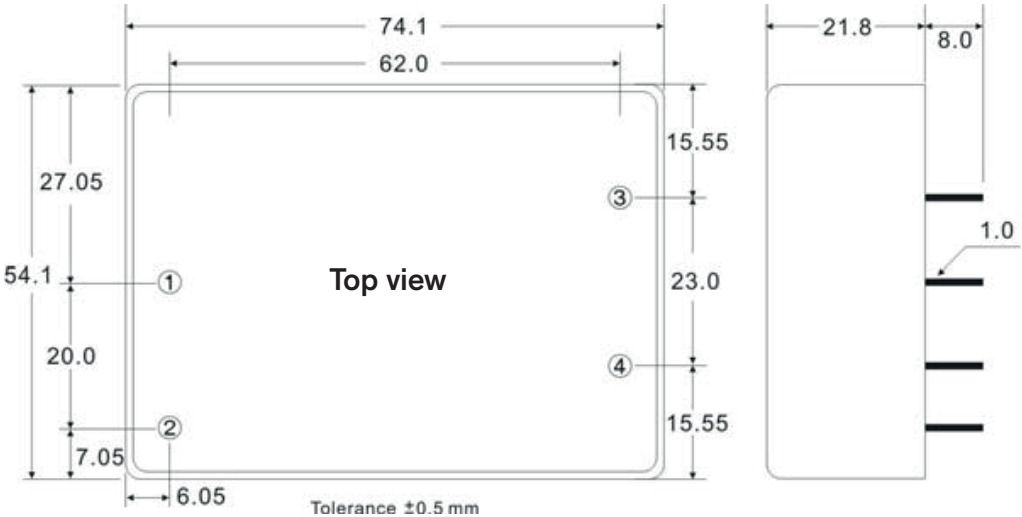

Pinout	
Pin	Single
1	AC IN (N)
2	AC IN (L)
3	-Vout
4	+Vout

Weight: 166 g (5.86 oz)

Dimensions in [mm]
 Tolerances: ±0.5 mm
 Pin tolerances: ±0.1 mm