

- High power density power supply (open frame)
- Certification according to IEC/EN/ES 60601-1 3rd edition for 2×MOPP
- Low leakage current <75 µA rated for BF applications
- EMC emission and immunity to IEC 60601-1-2 4th edition
- Risk management process according to ISO 14971 including risk management file
- Acceptance criteria for electronic assemblies according to IPC-A-610 Level 3
- Protection class I and II
- Operating up to 5000m altitude
- Ready to meet ErP directive, no load power consumption
- 5 year product warranty

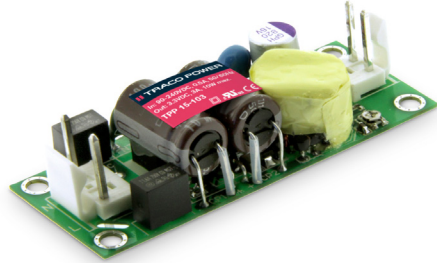

The TPP 15A-J AC/DC power supplies feature a reinforced double I/O isolation system according to medical safety standards IEC/EN/ES 60601-1 3rd edition for 2 × MOPP approved for an operating altitude of 5000 m. The earth leakage current is below 75 µA what makes the units suitable for BF (body floating) applications. The excellent efficiency of up to 88.5% offers a high power density in the packaging format 1.0" x 2.6". The full load operating temperature range covers -40°C to +60°C while it goes up to 85°C with 50% load derating. The units operate in compliance to the medical EMC emission and immunity levels according to latest standard IEC 60601-1-2 4th edition.

Models				
Order Code	Output Power (max.)	Output Voltage	Output Current (max.)	Efficiency (typ.)
TPP 15-103A-J	13.2 W	3.3 VDC	4'000 mA	84.0 %
TPP 15-105A-J	15 W	5.0 VDC	3'000 mA	86.0 %
TPP 15-109A-J		9.0 VDC	1'670 mA	86.0 %
TPP 15-112A-J		12 VDC	1'250 mA	87.0 %
TPP 15-115A-J		15 VDC	1'000 mA	87.0 %
TPP 15-124A-J		24 VDC	625 mA	88.0 %
TPP 15-136A-J		36 VDC	417 mA	88.0 %
TPP 15-148A-J		48 VDC	313 mA	88.5 %

Input Specifications

Input voltage range	– AC range (universal input)	85 – 264 VAC (derating of 4 %/V below 90 VAC input required)
	– DC range	120 – 370 VDC
Input frequency		47 – 63 Hz
Input current at full load	– at 115 VAC / 230 VAC	0.45 A max. / 0.30 A max.
Input protection		T1.6 A/250 VAC (internal fuse)
Input inrush current	– at 230 VAC	40 A max.
Zero load power consumption		0.05 W typ. (acc. ErP directive)

Output Specifications

Voltage adjustment		±10%
Voltage set accuracy		±1%
Regulation	– Input variation (Vin min. to Vin max.)	0.2% max.
	– Load variation (0 to 100%)	3.3 & 5.0 Vout models: 0.7% max. other output models: 0.5% max.
Minimum load		not required
Temperature coefficient		±0.02%/K
Hold-up time	– at 115 VAC	8 ms typ.
Start-up time		500 ms max.
Rise time		20 ms typ.
Ripple and noise (20 MHz Bandwidth)	3.3 & 5.0 Vout models: 9, 12 & 15 Vout models: 24 & 36 Vout models: 48 Vout model:	40 mVp-p typ. w. cap. 10µF/50V 1206 X5R MLCC 70 mVp-p typ. w. cap. 10µF/50V 1206 X5R MLCC 100 mVp-p typ. w. cap. 10µF/50V 1206 X5R MLCC 140 mVp-p typ. w. cap. 1µF/100V 1206 X7R MLCC
Transiente response	– Peak deviation (25% load step change) – Recovery time	5% typ. 500 µs typ.
Overvoltage protection		125 – 140% of nominal Vout
Current limitation		at 145% Iout typ.
Short circuit protection		continuous (automatic recovery), hiccup
Capacitive load	3.3 Vout model: 5 Vout model: 9 Vout model: 12 Vout model: 15 Vout model: 24 Vout model: 36 Vout model: 48 Vout model:	6'000 µF max. 4'000 µF max. 1'860 µF max. 1'200 µF max. 820 µF max. 470 µF max. 220 µF max. 150 µF max.

General Specifications

Temperature ranges	– Operating – Storage	–40°C to +85°C –40°C to +100°C
Output power derating	– Temperature – Low input voltage	24, 36 & 48 Vout models: 3.33 %/K above +70°C other output models: 2 %/K above +60°C 4 %/V below 90 VAC
Humidity (non condensing)		5 – 95 % rel. H.
Altitude during operation		5000 m max.
Switching frequency (at 230 VAC)		75 – 95 kHz (pulse width modulation)
Isolation voltage	– Input / Output (60 s) – Input / PE or Floating (60 s) – Output / PE or Floating (60 s)	4000 VAC (2 × MOPP insulation) 1500 VAC (1 × MOPP insulation) 1500 VAC (1 × MOPP insulation)

All specifications valid at nominal input voltage, full load and +25°C after warm-up time unless otherwise stated.

General Specifications (continued)

Leakage current (at 264 VAC / 60Hz)		75 μ A max.
Isolation resistance (at 500 VDC)		100 MOhm min.
Reliability	- calculated MTBF at +25°C acc. to MIL-HDBK-217F	3'063'000 h
Weight		19 g (0.67 oz)
EMI emission	- Conducted & Radiated input suppression - Harmonic current emissions - Voltage flicker	EN 55011 limits to IEC 60601-1-2 4th edition EN 55032 class B (internal filter) IEC / EN 61000-3-2, class A IEC / EN 61000-3-3, (class tba.)
EMC immunity	- ESD (electrostatic discharge) - Radiated immunity - Fast transient - Surge - Conducted immunity - Magnetic field immunity - Voltage dip and interruptions	EN 55024, EN 60601-1-2 4th edition EN 61000-4-2, air \pm 15 kV, contact \pm 8 kV, perf. criteria A EN 61000-4-3, 20 V/m, perf. criteria A EN 61000-4-4, \pm 2 kV, perf. criteria A EN 61000-4-5, \pm 1 kV perf. criteria A EN 61000-4-6, 20 Vrms, perf. criteria A EN 61000-4-8, 30 A/m, perf. criteria A EN 61000-4-11, 1 cycle perf. criteria A, 250 cycle perf. criteria B
Safety standards and certification		UL/IEC/EN 60950-1, UL/IEC/EN 62368-1 UL/IEC/EN 60601-1 3rd edition ANSI/AAMI ES60601-1:2005(R)2012 IEC/EN 60335-1, IEC/EN 61558
Shock and vibration		Vibration acc. IEC 60068-2-6 Shock acc. IEC 60068-2-27
Environmental compliance	- Reach - RoHS	RoHS directive 2011/65/EU
Protection class		class II prepared

Outline Dimensions

12, 15, 24, 36 & 48 Vout models - without heatsink

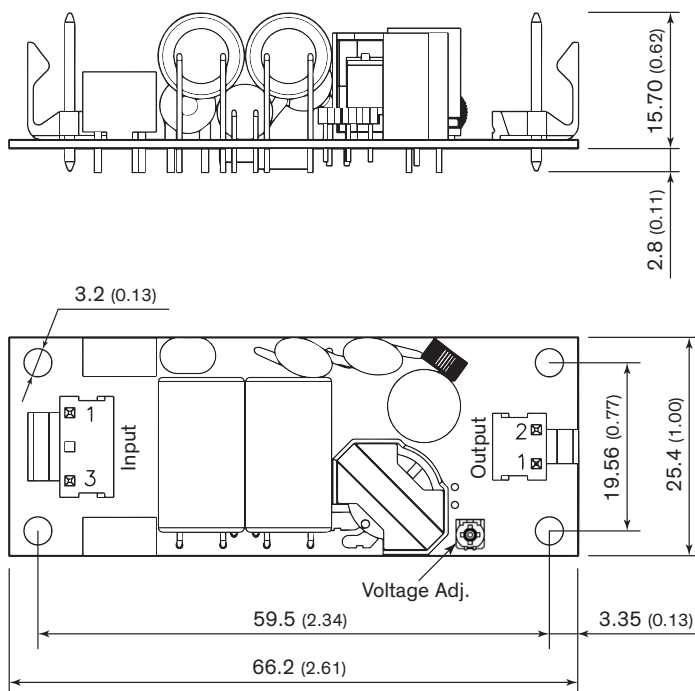

Each one of the 4 screw holes can be used as a PE connection for class I applications

Print thickness: 1.0 mm (0.04 inch)

Pin connectors

Input		Output	
Pin	Single	Pin	Dual
1	Line	1	-Vout
3	Neutral	2	+Vout

Input: JST series
mates with JST crimp terminal: SVH-21T-P1.1
and terminal housing: VHR-3N

Output: JST series
mates with JST crimp terminal: SVH-21T-P1.1
and terminal housing: VHR-2N

Dimension in mm, () = inch
Tolerances: x.x \pm 0.5 (\pm 0.02)
x.xx \pm 0.25 (\pm 0.01)

All specifications valid at nominal input voltage, full load and +25°C after warm-up time unless otherwise stated.

Outline Dimensions

3.3, 5 & 9 Vout models - with heatsink

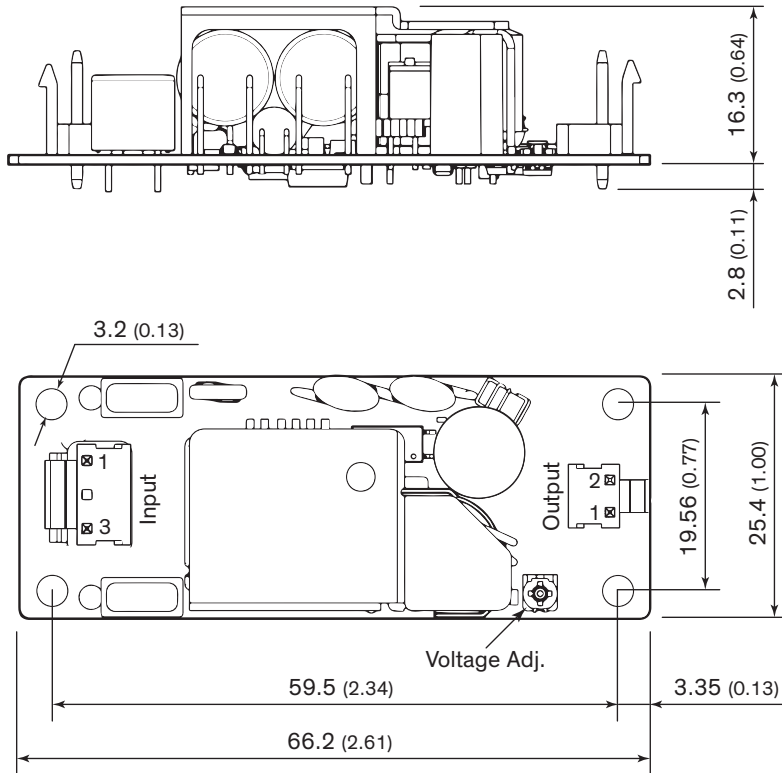

Each one of the 4 screw holes can be used as a PE connection for class I applications

Pin connectors

Input		Output	
Pin	Single	Pin	Dual
1	Line	1	-Vout
3	Neutral	2	+Vout

Input: JST series
mates with JST crimp terminal: SVH-21T-P1.1
and terminal housing: VHR-3N

Output: JST series
mates with JST crimp terminal: SVH-21T-P1.1
and terminal housing: VHR-2N

Dimension in mm, () = inch
Tolerances: x.x ±0.5 (±0.02)
x.xx ±0.25 (±0.01)