

ECS25,45 & 60 Series

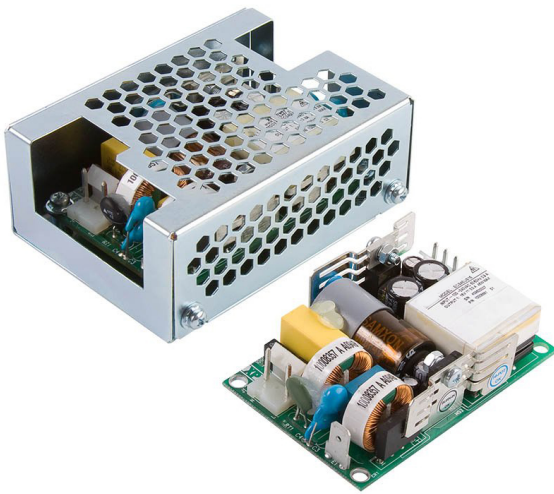

- IT & Medical Safety Approvals
- Very Small 2.0" x 3.0" Format
- Low Standby Power
- 25, 45 & 60 W – Convection Cooled Ratings
- High Convection Cooled Power Density up to 9.5 W/in³
- Class I & Class II Installations
- -20 °C to +70 °C Operation
- Low Earth Leakage Current
- 3 Year Warranty

The ECS25, 45 & 60 Series has been designed to minimise the no load power consumption and maximise efficiency in order to facilitate equipment design to the latest environmental legislation.

Approved for Class I and Class II applications, this range of single output AC-DC power supplies feature very high convection cooled power density in an industry leading 2" x 3" (51.0 mm x 76.2 mm) footprint. The very low profile, 1U compatible supplies meet EN55011/32 Level B conducted emissions with low earth leakage currents of 80 µA at 115 VAC or 160 µA at 230 VAC. Making these switchers ideal for industrial, IT and medical applications.

The series has single output versions from 5 V to 48 VDC, adjustable by ±10%. They are dual-fused for compliance with IEC60601-1 and efficiency up to 89%, so minimal excess heat is generated. They will deliver up to 60 W of power at +50 °C and up to +70 °C with derating.

Models and Ratings

Output Power - Convection Cooled	Output Voltage V1	Max Output Current	Model Number ¹⁾
25 W	12.0VDC	2.08 A	ECS25US12
25 W	15.0VDC	1.67 A	ECS25US15
25 W	24.0VDC	1.04 A	ECS25US24
25 W	48.0VDC	0.52 A	ECS25US48
30 W	5.0VDC	6.00 A	ECS45US05
45 W	12.0VDC	3.75 A	ECS45US12
45 W	15.0VDC	3.00 A	ECS45US15
45 W	24.0VDC	1.90 A	ECS45US24
45 W	48.0VDC	0.95 A	ECS45US48
40 W	5.0VDC	8.00 A	ECS60US05 ¹
60 W	12.0VDC	5.00 A	ECS60US12
60 W	15.0VDC	4.00 A	ECS60US15
60 W	24.0VDC	2.50 A	ECS60US24
60 W	48.0VDC	1.25 A	ECS60US48

Notes

1. For covered versions, add suffix '-C' to model number or order part number ECS25-60 COVER KIT for standalone cover. Not suitable for use in class II installations, derate output power by 20% with cover.

Input Characteristics

Characteristic	Minimum	Typical	Maximum	Units	Notes & Conditions
Input Voltage - Operating	80	115/230	264	VAC	Derate output power < 90 VAC. See fig. 1
Input Frequency	47	50/60	400	Hz	Agency approval 47-63 Hz
Power Factor		>0.5			230 VAC, 100% load EN61000-3-2 class A compliant
Input Current - No Load		0.01/0.02		A	115/230 VAC
Input Current - Full Load		0.45/0.25 0.75/0.45 0.95/0.60		A	115/230 VAC - ECS25 115/230 VAC - ECS45 115/230 VAC - ECS60
Inrush Current			40	A	230 VAC cold start, 25 °C
No Load Input Power		0.3	0.5	W	115/230 VAC
Earth Leakage Current		80/160 0.6/1.2	260	µA mA	115/230 VAC/50 Hz (Typ.), 264 VAC/60 Hz (Max.) 115/230 VAC/400 Hz
Input Protection	T3.15A/250 V internal fuse in both line and neutral				

Output Characteristics

Characteristic	Minimum	Typical	Maximum	Units	Notes & Conditions
Output Voltage - V1	5.0		48	VDC	See Models and Ratings table
Initial Set Accuracy			±1	%	50% load, 115/230 VAC
Output Voltage Adjustment	±10			%	Via potentiometer. See mech. details (page 9)
Minimum Load	0			A	
Start Up Delay		1		s	230 VAC full load (see fig.2)
Hold Up Time	16			ms	115 VAC full load (see fig.3)
Drift			±0.2	%	After 20 min warm up
Line Regulation			±0.5	%	90-264 VAC
Load Regulation			±1	%	0-100% load.
Transient Response - V1			4	%	Recovery within 1% in less than 500 µs for a 50-75% and 75-50% load step
Over/Undershoot - V1		3		%	See fig.4
Ripple & Noise			1	% pk-pk	20 MHz bandwidth (see fig.5 & 6)
Overvoltage Protection	115		140	%	Vnom DC.
Overload Protection	110		200	% I nom	Auto reset (see fig.7)
Short Circuit Protection					Continuous, trip & restart (hiccup mode)
Temperature Coefficient			0.05	%/°C	
Overtemperature Protection				°C	Not fitted

Input Voltage Derating

Figure 1

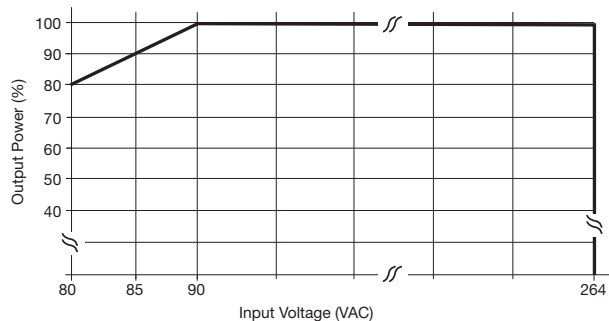

Start Up Delay From AC Turn On

Figure 2
Start up example from AC turn on
(230 VAC, 720 ms)

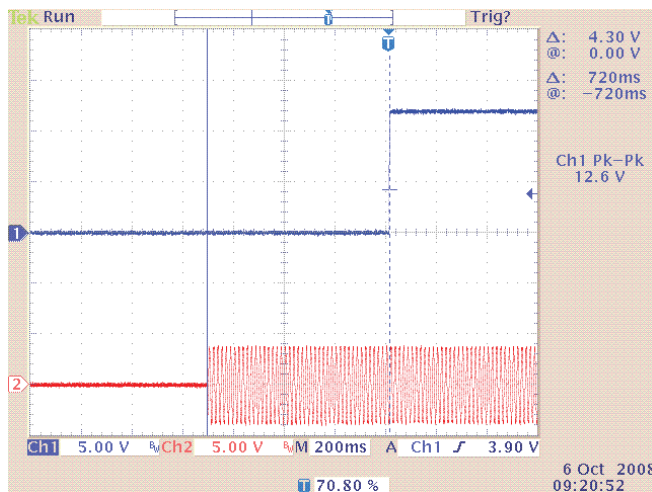

Hold Up Time From Loss of AC

Figure 3
Hold up example ECS45 at 45 W
load with 115 VAC input (17.2ms)

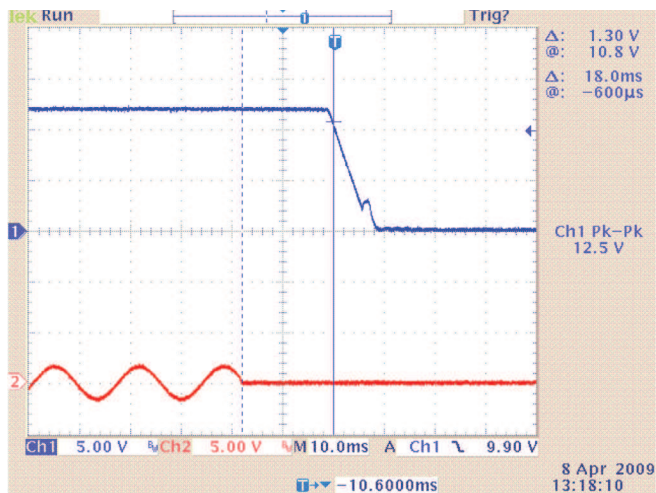

Typical Output Overshoot

Figure 4
Typical Output Overshoot
(ECS45US12, 230 VAC)

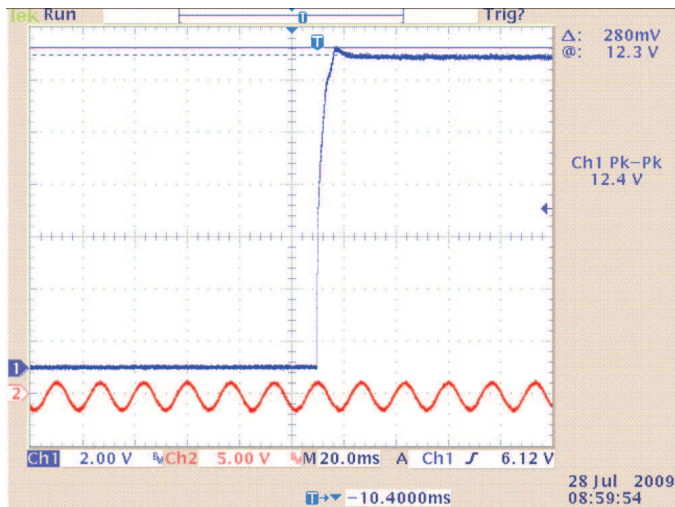

Output Ripple & Noise

Figure 5
ECS45US12 (45 W)
72 mV pk-pk ripple. 20 MHz BW

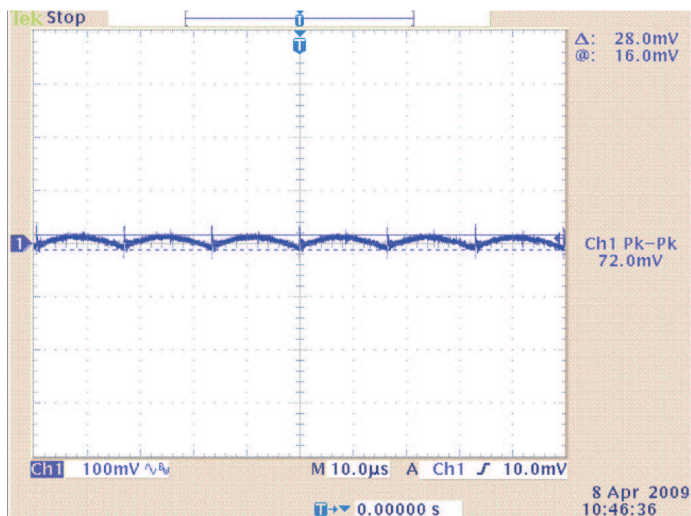

Output Ripple & Noise cont.

Figure 6
ECS45US48 (45 W)
188 mV pk-pk ripple. 20 MHz BW

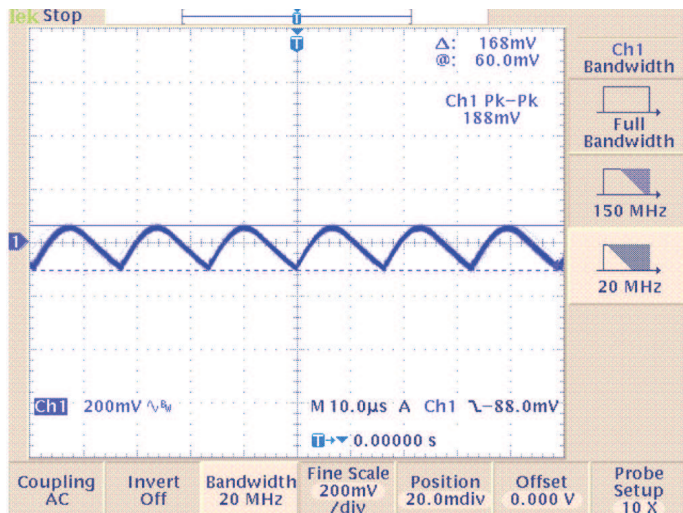

Output Overload Characteristic

Figure 7
Typical Overload
Characteristic
(ECS45US12 shown)

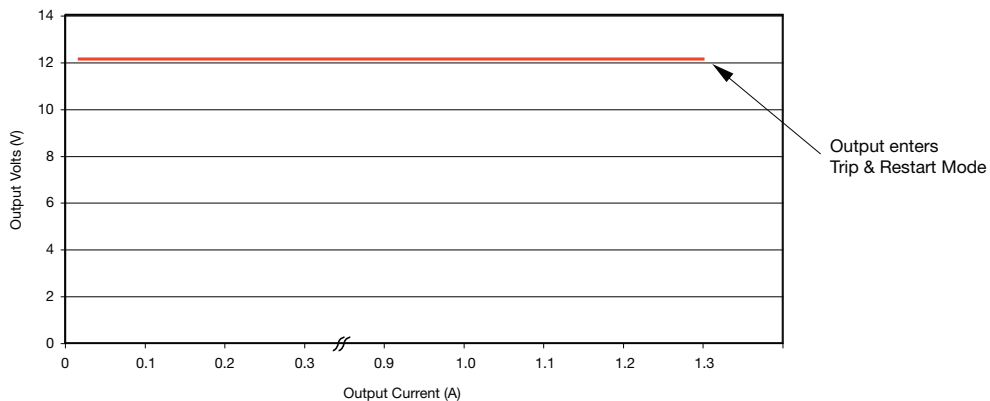

General Specifications

Characteristic	Minimum	Typical	Maximum	Units	Notes & Conditions
Efficiency		87		%	Full load (see fig.8 & 9)
Isolation: Input to Output Input to Ground Output to Ground	4000			VAC	
	1500			VAC	
	500			VDC	
Switching Frequency		65		kHz	
Power Density			7.9	W/in ³	
Mean Time Between Failure		1072		kHrs	MIL-HDBK-217F, Notice 2 +25 °C GB
		660			MIL-HDBK-217F, Notice 2 +50 °C GB
Weight			0.22 (100)	lb (g)	

Efficiency Versus Load

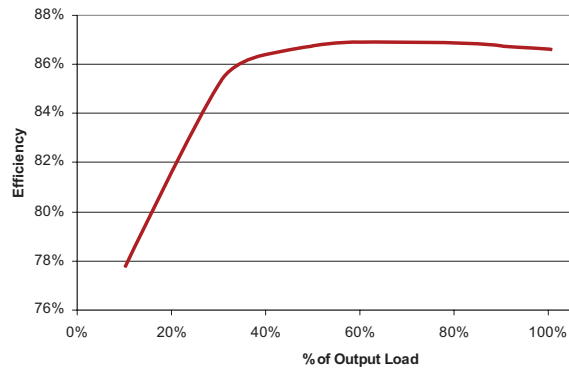

Figure 8
ECS45US12 at 230 VAC

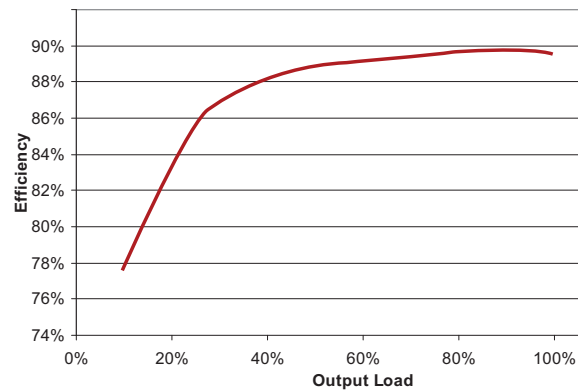

Figure 9
ECS45US48 at 230 VAC

Environmental

Characteristic	Minimum	Typical	Maximum	Units	Notes & Conditions
Operating Temperature	-20		+70	°C	Derate linearly from +50 °C at 2.5%/°C to 50% at 70 °C. (See fig.10 & Thermal Considerations)
Storage Temperature	-40		+85	°C	
Cooling					Convection cooled, see fig.10 & Thermal Considerations
Humidity	5		95	%RH	Non-condensing
Operating Altitude			3000	m	
Shock					3 x 30 g/11 ms shocks in both +ve & -ve directions along the 3 orthogonal axis, total 18 shocks.
Vibration					Three axis 5-500 Hz at 2 g x 10 sweeps

Derating Curve

Figure 10

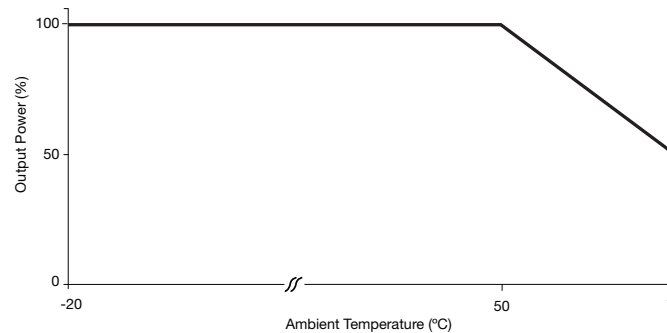

Electromagnetic Compatibility - Immunity

Phenomenon	Standard	Test Level	Criteria	Notes & Conditions
Low Voltage PSU EMC	EN61204-3	High severity level	as below	
Harmonic Current	EN61000-3-2	Class A		
Radiated	EN61000-4-3	3	A	
EFT	EN61000-4-4	3	A	
Surges	EN61000-4-5	Installation class 3	A	
Conducted	EN61000-4-6	3	A	
Dips and Interruptions	EN61000-4-11	Dip: 30% 10 ms	A	
		Dip: 60% 100 ms	B	
		Dip: 100% 5000 ms	B	
	EN60601-1-2	Dip: 30% 500 ms	A	
		Dip: 60% 100 ms	A	Load derating with 115 VAC input (typically 45% derate dependant on model & load)
		Dip: 100% 10 ms	A	
		Int.: >95% 5000 ms	B	

Electromagnetic Compatibility - Emissions

Phenomenon	Standard	Test Level	Criteria	Notes & Conditions
Conducted	EN55011/32	Class B		
Radiated	EN55011/32	Class B		ECS25
		Class A		ECS45/ECS60
Voltage Fluctuations	EN61000-3-3			

Safety Agency Approvals

Safety Agency	Safety Standard	Category
CB Report	IEC60950-1:2005 Ed 2 / IEC62368-1:2014	Information Technology
UL	UL 62368-1 & CAN/CSA C22.2 No. 62368-1-14	Information Technology
TUV	EN62368-1:2014/A11:2017	Information Technology
CE	LVD	

Safety Agency	Safety Standard	Category
CB Report	IEC60601-1 Ed 3 Including Risk Management	Medical
UL	ANSI/AAMI ES60601-1:2005 & CSA C22.2, No.60601-1:08	Medical
TUV	EN60601-1/A12:2006	Medical

Means of Protection		Category
Primary to Secondary	2 x MOPP (Means of Patient Protection)	IEC60601-1 Ed 3
Primary to Earth	1 x MOPP (Means of Patient Protection)	
Secondary to Earth	1 x MOPP (Means of Patient Protection)	

Equipment Protection Class	Safety Standard	Notes & Conditions
Class I & Class II	IEC60950-1:2005 Ed 2 / IEC62368-1:2014 & IEC60601-1 Ed 2	See safety agency conditions of acceptability for details

Mechanical Details - ECS25

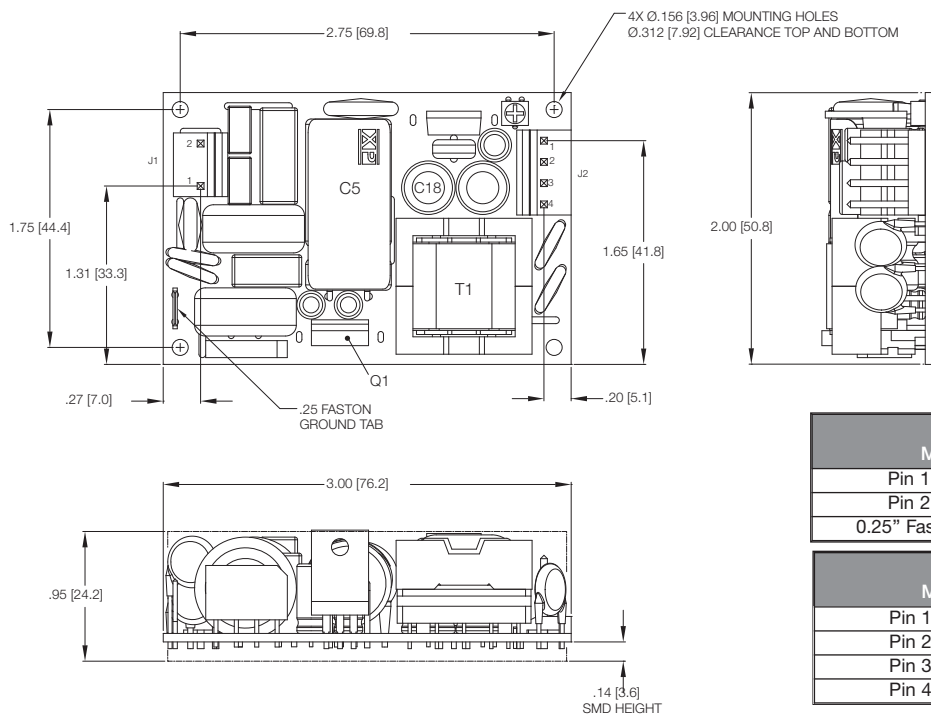

Input Connector J1 Molex PN 09-65-2038	
Pin 1	Line
Pin 2	Neutral
0.25" Faston	Earth

Input Connector J2 Molex PN 09-65-2048	
Pin 1	+V1
Pin 2	+V1
Pin 3	RTN
Pin 4	RTN

Notes

- All dimensions in inches (mm).
Tolerance .xx = ±0.02 (0.50); .xxx = ±0.01 (0.25)

- Weight 0.22 lbs (100 g)

J1 mates with Molex Housing PN 09-50-1031, J2 mates with Molex Housing PN 09-50-1041 and both with Molex Series 5194 Crimp Terminals
Faston ground tab requires insulated receptacle

Mechanical Details - ECS45US05

Weight: 2.20 lbs (1000 g)
Dimensions shown in inches (mm).

Input Connector J1 Molex PN 09-65-2038	
Pin 1	Line
Pin 2	Neutral
0.25" Faston	Earth

Input Connector J2 Molex PN 09-65-2048	
Pin 1	+V1
Pin 2	+V1
Pin 3	RTN
Pin 4	RTN

J1 mates with Molex Housing PN 09-50-1031, J2 mates with Molex Housing PN 09-50-1041 and both with Molex Series 5194 Crimp Terminals
Faston ground tab requires insulated receptacle

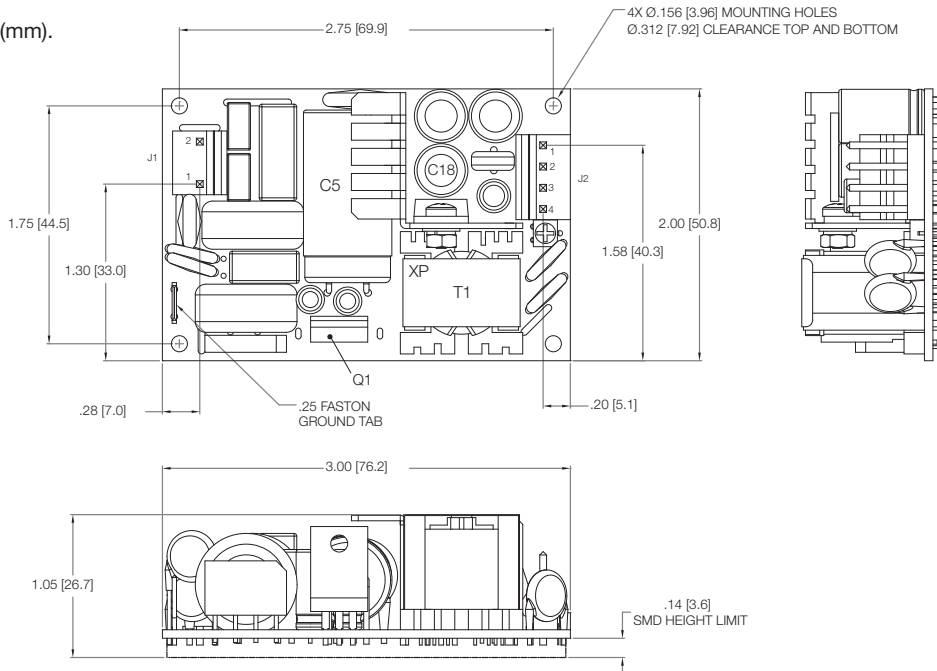

ECS45US other models

Input Connector J1 Molex PN 09-65-2038	
Pin 1	Line
Pin 2	Neutral
0.25" Faston	Earth

Input Connector J2 Molex PN 09-65-2048	
Pin 1	+V1
Pin 2	+V1
Pin 3	RTN
Pin 4	RTN

J1 mates with Molex Housing PN 09-50-1031, J2 mates with Molex Housing PN 09-50-1041 and both with Molex Series 5194 Crimp Terminals
Faston ground tab requires insulated receptacle

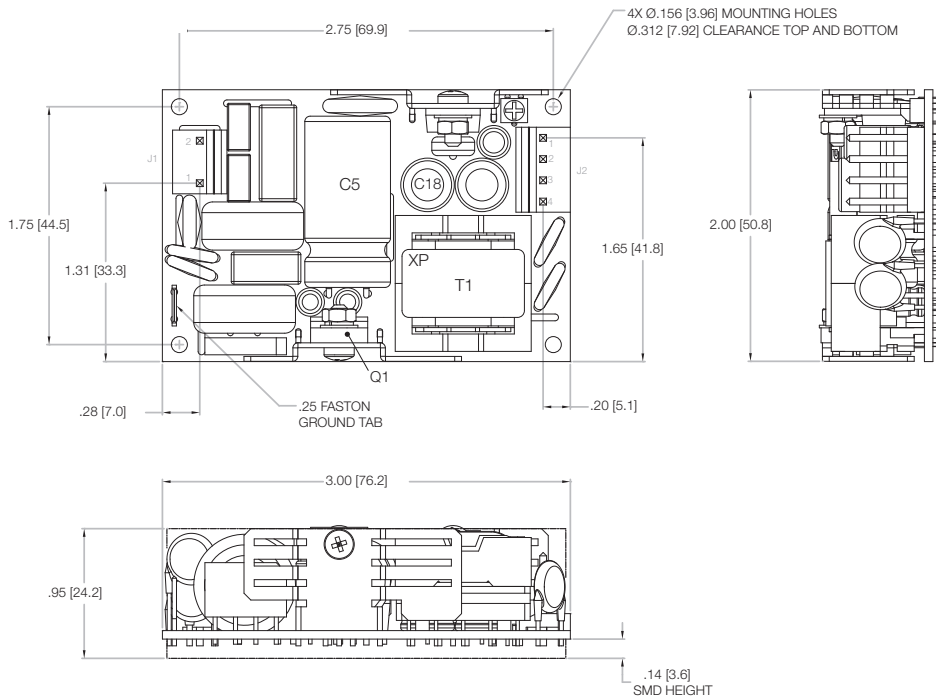

Notes

1. All dimensions in inches (mm).
Tolerance .xx = ±0.02 (0.50); .xxx = ±0.01 (0.25)

2. Weight: 0.22 lbs (100 g)

Mechanical Details - ECS60US05

Input Connector J1 Molex PN 09-65-2038	
Pin 1	Line
Pin 2	Neutral
0.25" Faston	Earth

J1 mates with Molex Housing PN 09-50-1031

Output Connector J2 Molex PN 09-65-2048	
Pin 1	+V1
Pin 2	+V1
Pin 3	RTN
Pin 4	RTN

J2 mates with Molex Housing PN 09-50-1041 and both with Molex Series 5194 Crimp Terminals
Faston ground tab requires insulated receptacle

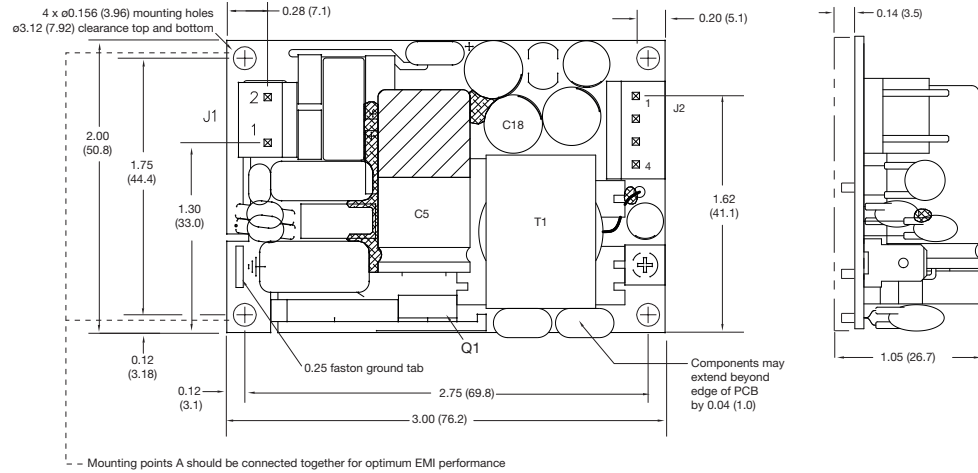

ECS60US other models

Input Connector J1 Molex PN 09-65-2038	
Pin 1	Line
Pin 2	Neutral
0.25" Faston	Earth

J1 mates with Molex Housing PN 09-50-1031

Output Connector J2 Molex PN 09-65-2048	
Pin 1	+V1
Pin 2	+V1
Pin 3	RTN
Pin 4	RTN

J2 mates with Molex Housing PN 09-50-1041 and both with Molex Series 5194 Crimp Terminals
Faston ground tab requires insulated receptacle

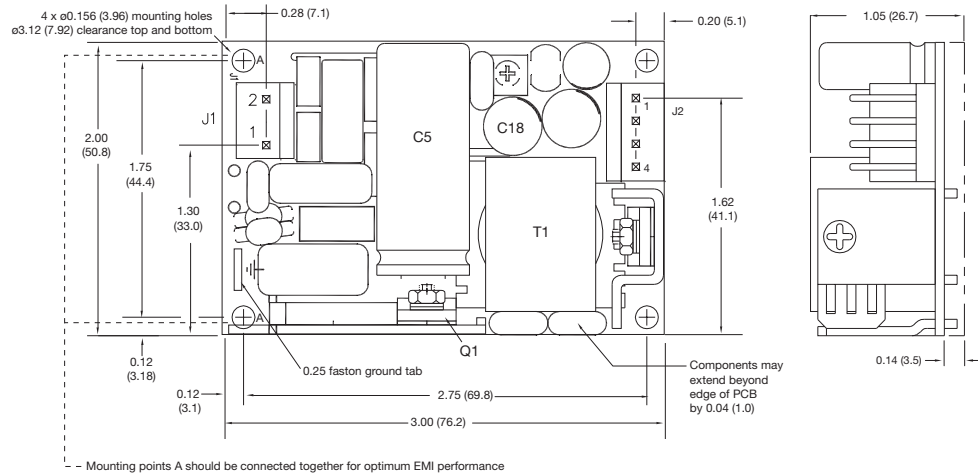

Notes

1. All dimensions in inches (mm).
Tolerance .xx = ±0.02 (0.50); .xxx = ±0.01 (0.25)

2. Weight: 0.22 lbs (100 g)

Covered Version - All models

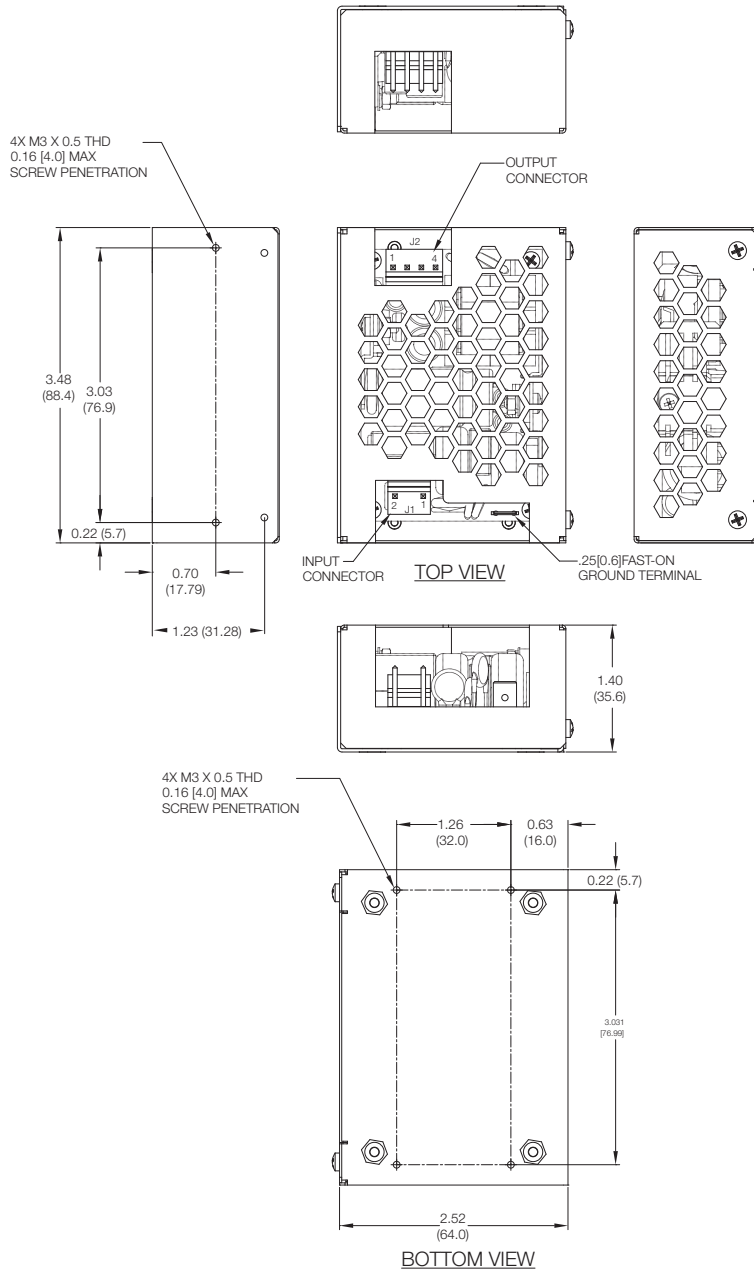

Thermal Considerations

In order to ensure safe operation of the PSU in the most adverse conditions permitted in the end-use equipment, the temperature of the components listed in the table below must not be exceeded. See mechanical drawings for component locations. Temperature should be monitored using K type thermocouples placed on the hottest part of the component (out of any direct air flow).

Temperature Measurements (Ambient ≤ 50 °C)	
Component	Max Temperature °C
T1	120 °C
Q1	110 °C
C5	105 °C
C18	105 °C