

5W CONVECTION COOLED

AC-DC POWER SUPPLIES

The VCE05 is a series of open frame and encapsulated AC-DC single output power supplies designed for low cost ITE and Industrial applications. The series provides two mechanical options including open frame and encapsulated PCB mount. With approvals to world-wide safety standards, compliance with class B for conducted and radiated emissions and a 130%, 30s peak load capability, these class II isolation parts benefit system designers with easy integration into a wide range of applications.



Features

- Compact size
- Single outputs from 3.3 to 48VDC
- Open frame & encapsulated PCB mount
- <0.3W no load input power
- Peak load capability
- No external components required
- Class II
- Low cost
- 3 year warranty

Applications



Dimensions

VCE05:
33.02 x 27.94 x 19.05mm (1.30 x 1.10 x 0.75")

VCE05-P:
30.8 x 25.4 x 17.9mm (1.20 x 1.00 x 0.705")

Models & Ratings

Model Number ⁽¹⁾	Output Voltage	Output Current		Output Power
		Nominal	Peak ⁽¹⁾	
VCE05US03	3.3VDC	1210mA	1573mA	5W
VCE05US05	5.0VDC	1000mA	1300mA	5W
VCE05US09	9.0VDC	550mA	722mA	5W
VCE05US12	12.0VDC	410mA	541mA	5W
VCE05US15	15.0VDC	330mA	433mA	5W
VCE05US24	24.0VDC	210mA	270mA	5W
VCE05US48	48.0VDC	100mA	135mA	5W

Notes:

1. Peak load lasting <30s with a maximum duty cycle of 10%, average output power not to exceed nominal.
2. For Open Frame version add suffix -P to model number, e.g. VCE05US12-P.

Input

Characteristic	Minimum	Typical	Maximum	Units	Notes & Conditions
Input Voltage Range	85		264	VAC	
Input Frequency	47		63	Hz	
Input Current - Full Load		0.10/0.06		A rms	At 115/230VAC
No Load Input Power			0.3	W	
Inrush Current			40	A	At 230/277VAC, cold start 25°C
Earth Leakage Current					Class II construction no earth
Input Protection	Internal T1.0 A/250VAC fuse fitted in line				

Output

Characteristic	Minimum	Typical	Maximum	Units	Notes & Conditions
Output Voltage	3.3		48	VDC	
Initial Set Accuracy			3/2	%	At 50% load for 3.3 & 5V models/Other models
Minimum Load	0			A	No minimum load required
Line Regulation			±1.0	%	3% for 03 & 05 models, 2% for others from 10% to 100% load
Load Regulation			3/2		
Start Up Delay			2	s	
Start Up Rise Time			14	ms	
Hold Up Time	6	9		ms	At full load and 115VAC
Transient Response			4	%	Deviation, recovery within 1% in less than 500µs for a 25% load change
Ripple & Noise			180	mV pk-pk	3.3-5V, 20MHz bandwidth
			1	% pk-pk	9V to 48V models, 20MHz bandwidth
Overvoltage Protection	115		140	% Vnom	Recycle input to reset
Overload Protection	110		180	%	
Short Circuit Protection					Trip & Restart (hiccup mode)
Temperature Coefficient			0.05	%/°C	

General

Characteristic	Minimum	Typical	Maximum	Units	Notes & Conditions
Efficiency		78		%	Model dependent
Isolation: Input to Output	3000			VAC	
Switching Frequency		40		kHz	
Power Density			14.98	W/cm ³	For '-P' version
Mean Time Between Failure		>400		khrs	MIL-HDBK-217F, +25°C GB
Weight		14 (0.03)		g (lb)	Open frame versions (-P)
		24 (0.053)			Encapsulated version

Environmental

Characteristic	Minimum	Typical	Maximum	Units	Notes & Conditions
Operating Temperature	-25		+70	°C	Derate linearly from 100% at +50°C to 50% at +70°C
Storage Temperature	-40		+85	°C	
Cooling	Convection-cooled				
Humidity			95	%RH	Non-condensing
Operating Altitude			3048	m	
Shock	IEC68-2-27, 30g, 11ms half sine, 3 times in each of 6 axes				
Vibration	IEC68-2-6, 2g, 10Hz to 500kHz, 10mins/cycle, 60 mins each cycle				

Efficiency Graphs

VCE05US12-P

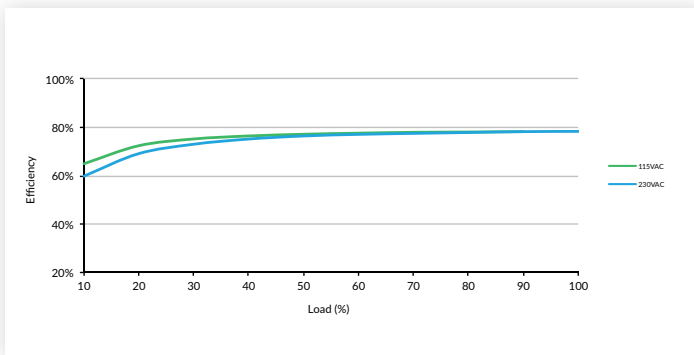

VCE05US24-P

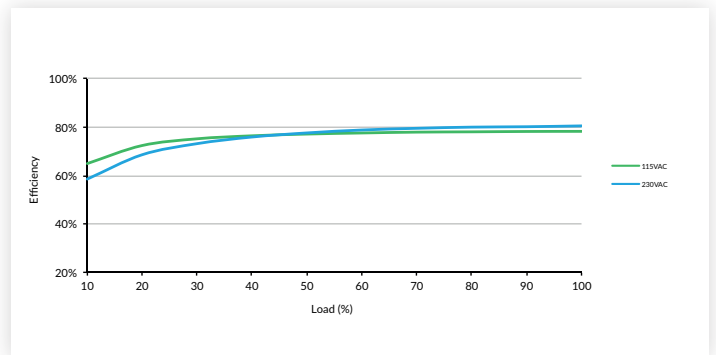

Safety Approvals

Certification	Standard	Notes & Conditions
CB	IEC60950-1	ITE
	IEC62368-1	
UL	UL62368-1	ITE
TUV	EN62368-1	
CE	Meets all applicable directives	
UKCA	Meets all applicable legislation	

EMC: Emissions

Phenomenon	Standard	Test Level	Notes & Conditions
Conducted	EN55032	Class B	If output is connected to a ground additional external components will be required. See application notes
Radiated	EN55032	Class B	
Harmonic Current	EN61000-3-2	Class A	
Voltage Flicker	EN61000-3-3		

EMC: Immunity

Phenomenon	Standard	Test Level	Criteria	Notes & Conditions
ESD Immunity	EN61000-4-2	$\pm 6\text{kV}$ contact, $\pm 8\text{kV}$ air discharge	A	
Radiated Immunity	EN61000-4-3	10 V/m	A	
EFT/Burst	EN61000-4-4	3	A	
Surge	EN61000-4-5	2	A	Line to line
Conducted	EN61000-4-6	10Vrms	A	
Magnetic Fields	EN61000-4-8	30A/m	A	
Dips and Interruptions	EN61000-4-11 (115VAC)	70% U_T (80.5VAC) for 100ms	A	A at High Line, B at Low Line
		40% U_T (46VAC) for 200ms	B	
		<5% U_T (0VAC) for 10ms	A	
		<5% U_T (0VAC) for 5000ms	B	
	EN61000-4-11 (230VAC)	70% U_T (161VAC) for 100ms	A	A at High Line, B at Low Line
		40% U_T (92VAC) for 200ms	A	
		<5% U_T (0VAC) for 10ms	A	
		<5% U_T (0VAC) for 5000ms	B	

Applications Notes

EMC with output grounded

This product is designed for class II operation, but if there is a requirement to connect the output to ground then the common mode choke shown in the diagram can be added to improve emissions.

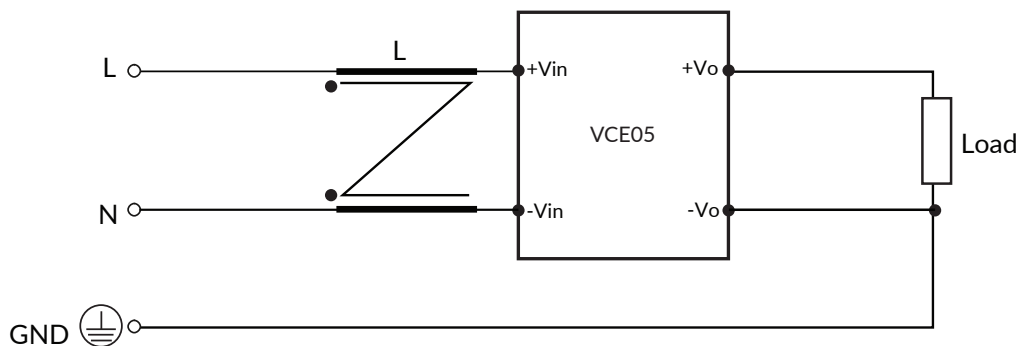

Suggested value - L: 15mH, 500mA common mode choke such as Würth Elektronik 7446620015.

Mechanical Details

Encapsulated

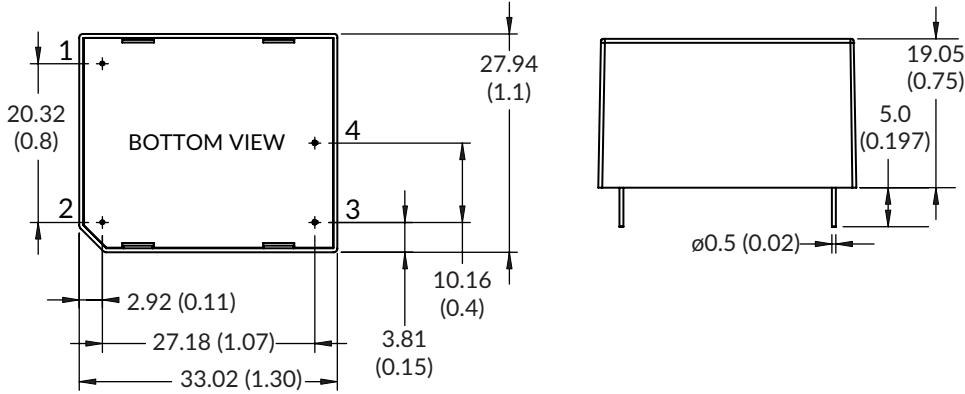

Pin Connections	
Pin	Single
1	ACL
2	ACN
3	-Vout
4	+Vout

Open Frame (-P)

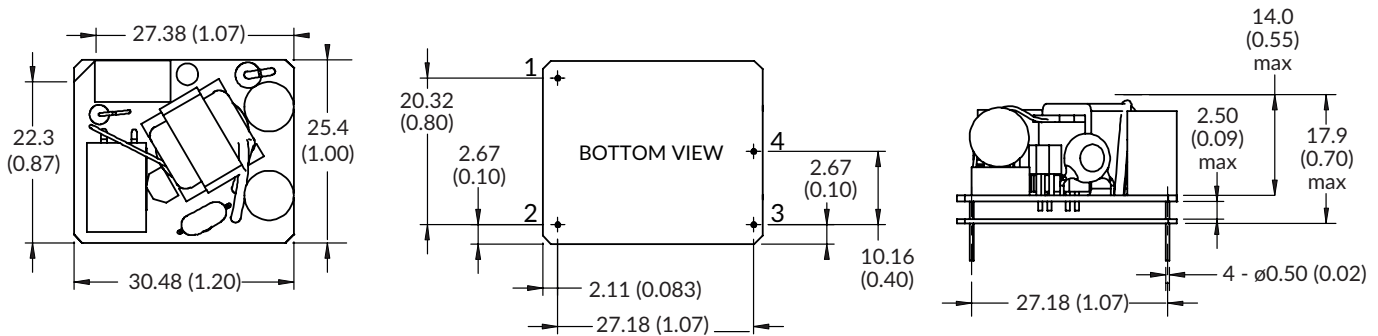

Notes:

1. Dimensions in mm (inches).
2. Weight: Open frame versions (-P): 14g (0.03lbs)
Encapsulated: 24g (0.053lbs)

3. Tolerances: x.xx (x.x) = ± 0.5 (± 0.02). x.xxx (x.xx) = ± 0.25 (± 0.01)