

10W CONVECTION COOLED

AC-DC POWER SUPPLIES

The VCE10 is a series of open frame and encapsulated AC-DC single output power supplies designed for low cost ITE, industrial and domestic applications. The series provides two mechanical options including open frame and encapsulated PCB mount. With approvals to world-wide safety standards including ITE and Household, compliance with class B for conducted and radiated emissions, these class II isolation parts benefit system designers with easy integration into a wide range of applications.

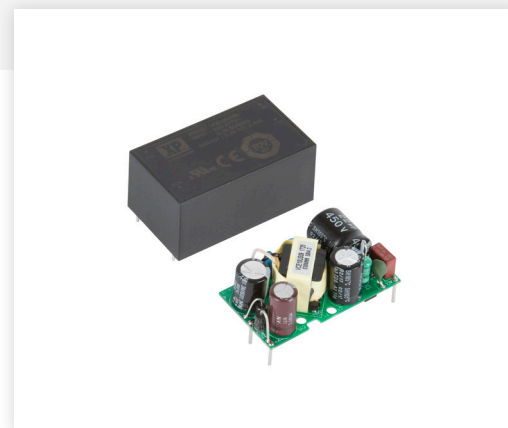

Features

- Compact PCB mount package
- Encapsulated & open frame versions
- ITE & household appliance approvals
- Class II operation
- Input range 85 to 305VAC
- Single outputs from 3.3 to 48VDC
- No load input power <0.3W
- Low cost
- -25°C to +70°C operating temperature
- 3 year warranty

Applications



Household Appliances



Industrial Electronics



Instrumentation



IoT



Security



Technology

Dimensions

VCE10:

2.00 x 1.15 x 0.91" (50.8 x 29.2 x 23.1 mm)

VCE10-P:

1.90 x 1.05 x 0.88" (48.3 x 26.7 x 22.4 mm)

Models & Ratings

Model Number ⁽¹⁾	Output Voltage	Output Current	Output Power
VCE10US03	3.3VDC	2400mA	8W
VCE10US05	5.0VDC	2000mA	10W
VCE10US09	9.0VDC	1110mA	10W
VCE10US12	12.0VDC	830mA	10W
VCE10US15	15.0VDC	670mA	10W
VCE10US24	24.0VDC	420mA	10W
VCE10US48	48.0VDC	210mA	10W

Notes:

1. For Open Frame version add suffix -P to model number, e.g. VCE10US12-P.

Summary

Characteristic	Minimum	Typical	Maximum	Units	Notes & Conditions
Input Voltage Range	85		305	VAC	Derate from 100% at 90 VAC to 90% at 85VAC
No Load Input Power			0.3	W	
Efficiency		80		%	Model dependent
Operating Temperature	-25		+70	°C	Derate linearly from 100% at +50°C to 50% at +70°C
EMC	EN55032 Level B Conducted & Radiated, EN61000-3-2, EN61000-3-3, EN55024				
Safety Approvals	IEC62368-1, IEC60335-1, IEC60950-1, EN62368-1, EN60335-1, UL62368-1				

Input

Characteristic	Minimum	Typical	Maximum	Units	Notes & Conditions
Input Voltage Range	85		305	VAC	
Input Frequency	47		63	Hz	
Input Current - Full Load		0.20/0.12		A rms	At 115/230VAC
No Load Input Power			0.3	W	
Inrush Current			40	A	At 230VAC, cold start 25°C
Earth Leakage Current					Class II construction no earth
Input Protection	Internal T1.0 A/300 VAC fuse fitted in line				

Output

Characteristic	Minimum	Typical	Maximum	Units	Notes & Conditions
Output Voltage	3.3		48	VDC	
Initial Set Accuracy			3/2	%	3% for 3.3 & 5V models, 2% for others at 50% load
Minimum Load	0			A	No minimum load required
Total Regulation			5/3	%	For 3.3 & 5V models/other models: from 10% to 100% load. Includes initial set accuracy, line and load regulation. Total regulation is 7% max from 0% to 100% load.
Start Up Delay			2	s	
Start Up Rise Time			35	ms	
Hold Up Time	16	20		ms	At full load and 115VAC
Transient Response			4	%	Deviation, recovery within 1% in less than 500µs for a 25% load change
Ripple & Noise			120	mV pk-pk	3.3-5V, 20 MHz bandwidth
			1	% pk-pk	9V to 48V models, 20 MHz bandwidth
Overvoltage Protection	115		140	% Vnom	210% typical for 03 model, auto recovery
Overload Protection	110		180	%	
Short Circuit Protection					Trip & Restart (hiccup mode)
Temperature Coefficient			0.05	%/°C	

General

Characteristic	Minimum	Typical	Maximum	Units	Notes & Conditions
Efficiency		80		%	Model dependent
Isolation: Input to Output	3000			VAC	
Switching Frequency	5		50	kHz	Varied load
Power Density			5.7	W/in ³	For '-P' version
Mean Time Between Failure	550	600		khrs	MIL-HDBK-217F, +25°C GB
Weight		0.051 (23)		lb (g)	Open frame versions (-P)
		0.115 (52)			Encapsulated version

Environmental

Characteristic	Minimum	Typical	Maximum	Units	Notes & Conditions
Operating Temperature	-25		+70	°C	Derate linearly from 100% at +50 °C to 50% at +70 °C
Storage Temperature	-40		+85	°C	
Cooling	Convection-cooled				
Humidity			95	%RH	Non-condensing
Operating Altitude			5000	m	
Shock	IEC68-2-27, 30g, 11ms half sine, 3 times in each of 6 axes				
Vibration	IEC68-2-6, 2g, 10Hz to 500kHz, 10 mins/cycle, 60 mins each cycle				

Efficiency Graphs

VCE10US12-P

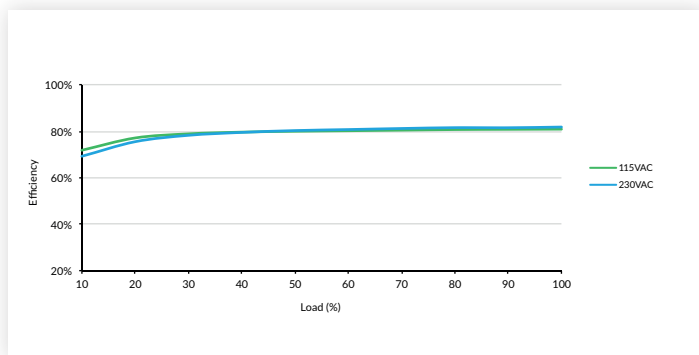

VCE10US24-P

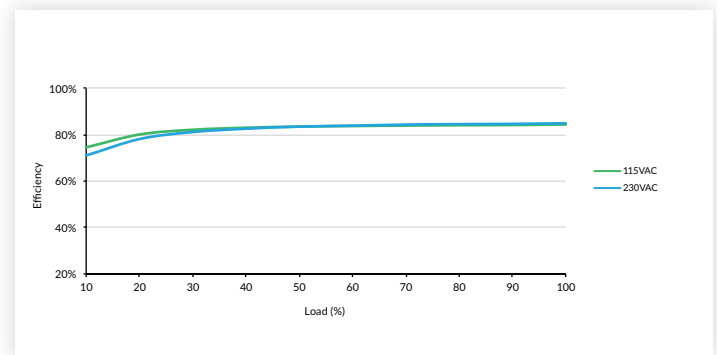

Safety Approvals

Certification	Standard	Notes & Conditions
CB	IEC60950-1	ITE
	IEC62368-1	
	IEC60335-1	Household, Encapsulated Version
	IEC61558-1	Power Supply Units
UL	UL62368-1	ITE
TUV	EN62368-1	
CE	Meets all applicable directives	
UKCA	Meets all applicable legislation	

EMC: Emissions

Phenomenon	Standard	Test Level	Notes & Conditions
Conducted	EN55032	Class B	If output is connected to a ground additional external components will be required. See application notes
Radiated	EN55032	Class B	
Harmonic Current	EN61000-3-2	Class A	
Voltage Flicker	EN61000-3-3		

EMC: Immunity

Phenomenon	Standard	Test Level	Criteria	Notes & Conditions
ESD Immunity	EN61000-4-2	±6kV contact, ±8kV air discharge	A	
Radiated Immunity	EN61000-4-3	10 V/m	A	
EFT/Burst	EN61000-4-4	3	A	
Surge	EN61000-4-5	2	A	Line to line
Conducted	EN61000-4-6	10Vrms	A	
Magnetic Fields	EN61000-4-8	30A/m	A	
Dips and Interruptions	EN61000-4-11 (115VAC)	70% U_T (80.5 VAC) for 100ms	A	
		40% U_T (46 VAC) for 200ms	B	
		<5% U_T (0 VAC) for 10ms	A	
		<5% U_T (0 VAC) for 5000ms	B	
	EN61000-4-11 (230VAC)	70% U_T (161 VAC) for 100 ms	A	
		40% U_T (92 VAC) for 200ms	A	
		<5% U_T (0 VAC) for 10ms	A	
		<5% U_T (0 VAC) for 5000ms	B	

VCE10 Series

Applications Notes

EMC with output grounded

This product is designed for class II operation, but if there is a requirement to connect the output to ground then the common mode choke shown in the diagram can be added to improve emissions.

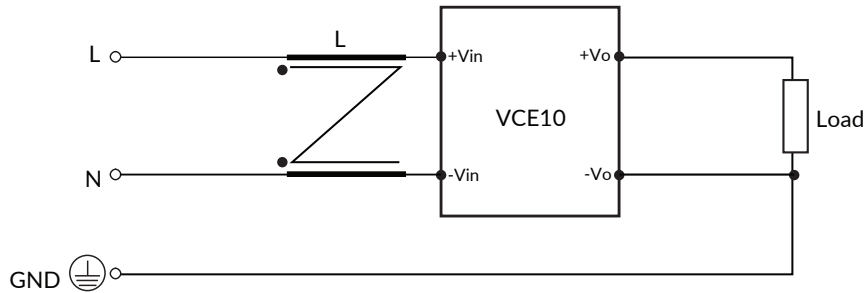

Suggested value - L: 20mH, 500mA common mode choke such as Würth Elektronik 744821120.

VCE10 Series

Mechanical Details

Encapsulated

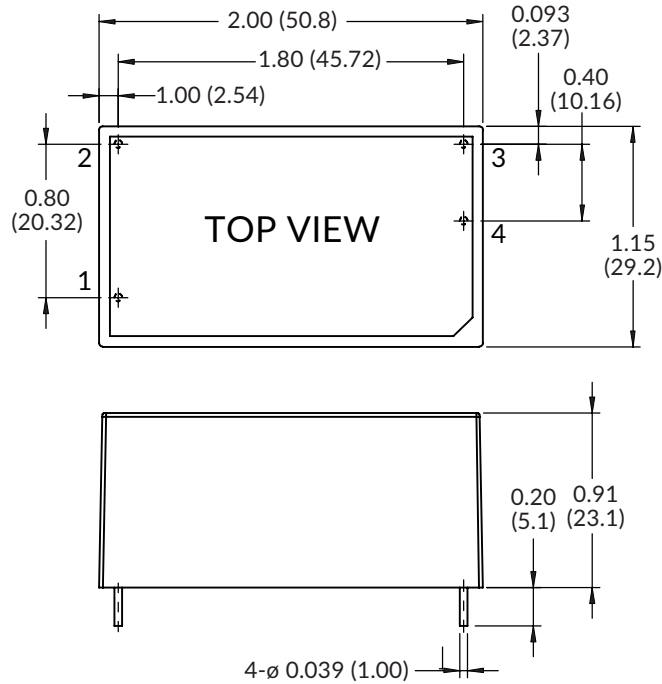

Pin Connections	
Pin	Single
1	ACN
2	ACL
3	-Vout
4	+Vout

Open Frame (-P)

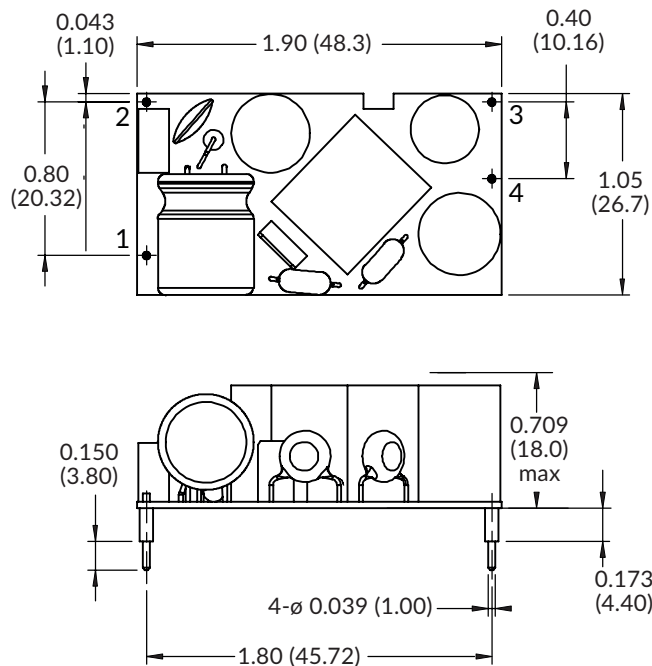

Notes:

1. Dimensions in inches (mm).
2. Weight: Open frame versions (-P): 0.051 lbs (23 g) Encapsulated: 0.115 lbs (52 g)
3. Tolerances: x.x (x.xx) = ± 0.02 (± 0.5) x.xx (x.xxx) = ± 0.01 (± 0.25)

Specifications subject to change without notice.