

20W CONVECTION COOLED

AC-DC POWER SUPPLIES

The VCE20 is a series of open frame and encapsulated AC-DC single output power supplies designed for low cost ITE, industrial and domestic applications. The series provides two mechanical options including open frame and encapsulated PCB mount. With approvals to world-wide safety standards including ITE and Household, compliance with class B for conducted and radiated emissions, these class II isolation parts benefit system designers with easy integration into a wide range of applications.



Features

- 85 to 305VAC Input
- Single Outputs from 3.3 to 48VDC
- PCB Mount
- Encapsulated & Open Frame
- ITE & Household Appliance Approvals
- EN55035 Immunity Standard
- Class II
- Low Cost
- 3 Year Warranty

Applications



Household Appliances



Industrial Electronics



Instrumentation



IoT



Security



Technology

Dimensions

VCE20:

2.60 x 1.30 x 0.92" (66.0 x 33.0 x 23.4 mm)

VCE20-P:

2.50 x 1.20 x 0.86" (63.5 x 30.5 x 21.8 mm)

Models & Ratings

Model Number	Output Voltage	Output Current	Output Power
VCE20US03	3.3VDC	4.55A	15W
VCE20US05	5.0VDC	4.00A	20W
VCE20US09 ⁽¹⁾	9.0VDC	2.22A	20W
VCE20US12 ⁽¹⁾	12.0VDC	1.67A	20W
VCE20US15 ⁽¹⁾	15.0VDC	1.33A	20W
VCE20US24 ⁽¹⁾	24.0VDC	0.83A	20W
VCE20US48 ⁽¹⁾	48.0VDC	0.42A	20W

Notes:

1. For Open Frame version add suffix -P to model number, e.g. VCE20US12-P.

Summary

Characteristic	Minimum	Typical	Maximum	Units	Notes & Conditions	
Input Voltage Range	85		305	VAC	Derate from 100% at 90VAC to 90% at 85VAC	
No Load Input Power			0.3	W		
Efficiency		85		%	Model dependent	
Operating Temperature	-25		+70	°C	3V3 & 5V models	Derate output linearly from 100% at +45°C to 45% at +70°C
					Other models	Derate output linearly from 100% at 50°C to 50% at 70°C
EMC	EN55032 Level B Conducted & Radiated, EN601000-3-2, EN61000-3-3, EN55035					
Safety Approvals	IEC62368-1, IEC60335-1, IEC60950-1, EN62368-1, EN60335-1, UL62368-1					

Input

Characteristic	Minimum	Typical	Maximum	Units	Notes & Conditions
Input Voltage Range	85		305	VAC	Derate from 100% at 90VAC to 90% at 85VAC
Input Frequency	47		63	Hz	
Input Current - Full Load		0.35/0.22		A rms	At 115/230VAC
No Load Input Power			0.3	W	
Inrush Current			40	A	At 230VAC, cold start 25°C
Earth Leakage Current					Class II construction no earth
Input Protection	Internal T1.0 A/300VAC fuse fitted in line				

Output

Characteristic	Minimum	Typical	Maximum	Units	Notes & Conditions
Output Voltage	3.3		48	VDC	
Initial Set Accuracy			1.5/1.0	%	1.5% for 3V3 & 5V models, 1% for others at 50% load
Minimum Load	0			A	No minimum load required
Line Regulation			1	%	
Load Regulation			1		
Start Up Delay			2	s	
Start Up Rise Time			35	ms	
Hold Up Time	8	14		ms	At full load and 115VAC
Transient Response			4	%	Deviation, recovery within 1% in less than 500µs for a 25% load change
Ripple & Noise			100	mV pk-pk	3.3-5V models, 20 MHz bandwidth
			1	% pk-pk	9V to 48V models, 20 MHz bandwidth
Overvoltage Protection	115		140	% Vnom	210% typical for 3V3 model, auto recovery
Overload Protection	110		190	%	
Short Circuit Protection					Trip & Restart (hiccup mode)
Temperature Coefficient			0.05	%/°C	

General

Characteristic	Minimum	Typical	Maximum	Units	Notes & Conditions
Efficiency		85		%	Model dependent
Isolation: Input to Output	3000			VAC	
Switching Frequency	5		65	kHz	Varied load
Power Density			7.7	W/in ³	For '-P' version
Mean Time Between Failure	550	600		khrs	MIL-HDBK-217F, +25°C GB
Weight		0.088 (40)		lb (g)	Open frame versions (-P)
		0.198 (90)			Encapsulated version

Environmental

Characteristic	Minimum	Typical	Maximum	Units	Notes & Conditions
Operating Temperature	-25		+70	°C	3V3 & 5V models: derate output linearly from 100% at +45°C to 45% at +70°C. Other models: derate output linearly from 100% at 50 °C to 50% at 70°C.
Storage Temperature	-40		+85	°C	
Cooling	Convection-cooled				
Humidity			95	%RH	Non-condensing
Operating Altitude			5000	m	
Shock	IEC68-2-27, 30g, 11ms half sine, 3 times in each of 6 axes				
Vibration	IEC68-2-6, 2g, 10Hz to 500kHz, 10 mins/cycle, 60 mins each cycle				

Efficiency Graphs

VCE20US12-P

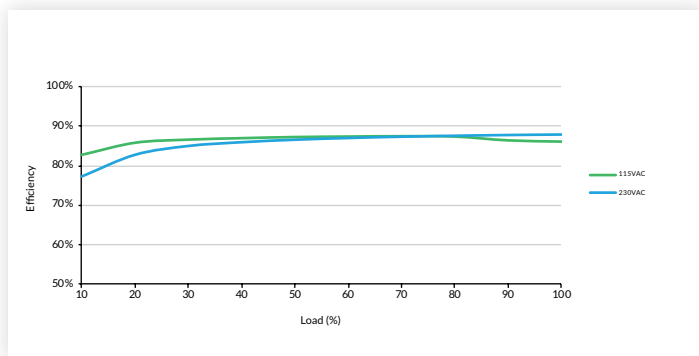

VCE20US24-P

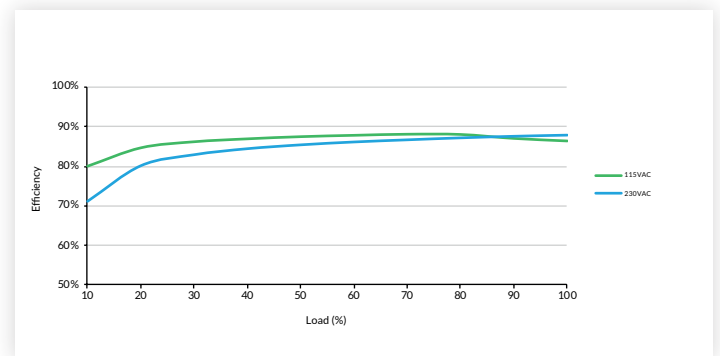

Safety Approvals

Certification	Standard	Notes & Conditions
CB	IEC60950-1	ITE
	IEC62368-1	
IEC	IEC60335-1	Household, informative only
UL	UL62368-1	ITE
TUV	EN62368-1	
CE	Meets all applicable directives	
UKCA	Meets all applicable legislation	

EMC: Emissions

Phenomenon	Standard	Test Level	Notes & Conditions
Conducted	EN55032	Class B	If output is connected to a ground additional external components will be required. See application notes
Radiated	EN55032	Class B	
Harmonic Current	EN61000-3-2	Class A	
Voltage Flicker	EN61000-3-3		

EMC: Immunity

Phenomenon	Standard	Test Level	Criteria	Notes & Conditions
ITE	EN55035	As below		As below
ESD Immunity	EN61000-4-2	±6kV contact, ±8kV air discharge	A	
Radiated Immunity	EN61000-4-3	10 V/m	A	
EFT/Burst	EN61000-4-4	3	A	
Surge	EN61000-4-5	2	A	Line to line
Conducted	EN61000-4-6	10Vrms	A	
Magnetic Fields	EN61000-4-8	30A/m	A	
Dips and Interruptions	EN61000-4-11 (115VAC)	70% U_T (80.5VAC) for 100ms	A	
		40% U_T (46VAC) for 200ms	B	
		<5% U_T (0VAC) for 10ms	A	
		<5% U_T (0VAC) for 5000ms	B	
	EN61000-4-11 (230VAC)	70% U_T (161VAC) for 100 ms	A	
		40% U_T (92VAC) for 200ms	A	
		<5% U_T (0VAC) for 10ms	A	
		<5% U_T (0VAC) for 5000ms	B	

Applications Notes

EMC with output grounded

This product is designed for class II operation, but if there is a requirement to connect the output to ground then an X-capacitor as shown in the diagram can be added to improve emissions.

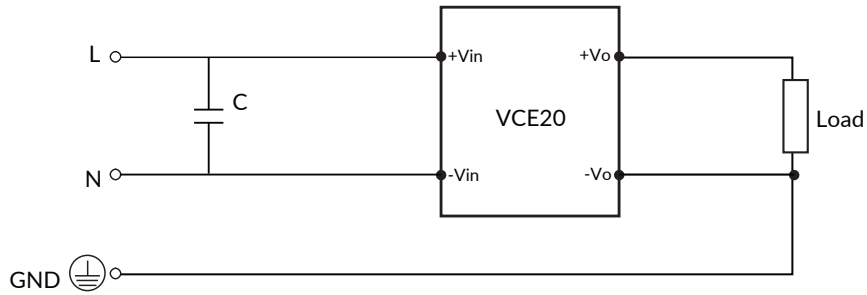

Suggested value - C: X2 cap, 0.4 μ F/310V, 10%, metallised polypropylene film.

VCE20 Series

Mechanical Details

Encapsulated

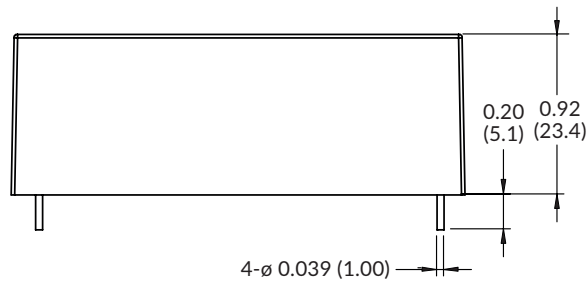
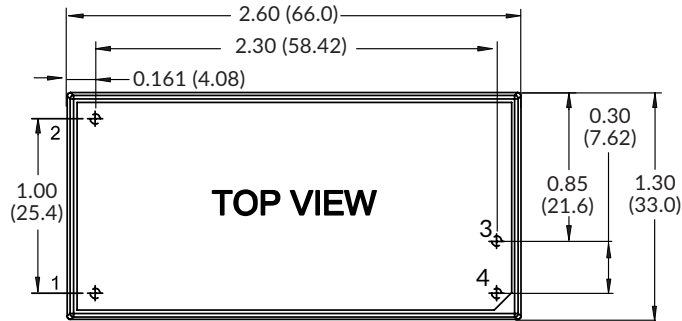

Pin Connections	
Pin	Single
1	ACN
2	ACL
3	-Vout
4	+Vout

Open Frame (-P)

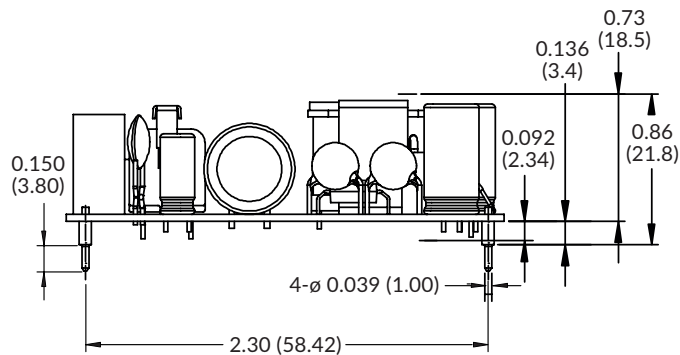
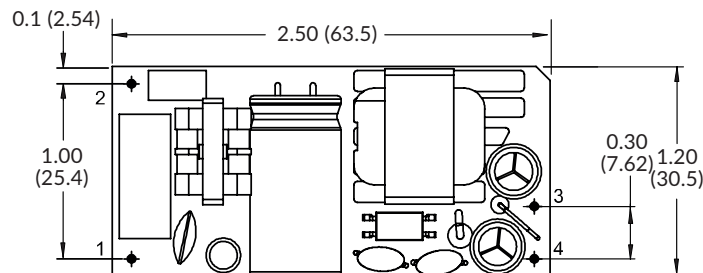

Notes:

1. Dimensions in inches (mm).
2. Weight: Open frame versions (-P): 0.088 lbs (40 g) Encapsulated: 0.198 lbs (90 g)
3. Tolerances: x.x (x.xx) = ± 0.02 (± 0.5) x.xx (x.xxx) = ± 0.01 (± 0.25)

Specifications subject to change without notice.