

- Forced air cooled design approach
- Operating temperature range  $-30^{\circ}\text{C}$  to  $+70^{\circ}\text{C}$
- I/O reinforced isolation 4250 VAC
- Over voltage category (OVC III)
- High efficiency up to 92%
- Operating up to 5000 m altitude
- Internal EN 55032 conducted class B filter
- Protection class I prepared
- 3-year product warranty



UL 62368-1 IEC 62368-1

The TCI 500 is a 500 Watt forced air cooled AC/DC enclosed power supply series with a 4250 VAC reinforced isolation system. Traco Power's new TCI line focuses on maximizing the proficiency of conduction cooled systems as it offers superior temperature behavior when mounted on a metal chassis or baseplate. Excellent efficiency of up to 92% allows the TCI 500 series to operate from  $-30$  to  $+70^{\circ}\text{C}$  with load derating. They also meet OVC III requirements and can operate at up to 5000 m altitude. Active power factor correction, EMC characteristics dedicated for applications in industrial/automation and test & measurement fields and high reliability make the new TCI line an ideal solution for any demanding industrial application.

Models				
Order Code	Output Power max.	Output Voltage nom. (adjustable)	Output Current max.	Efficiency typ.
TCI 500-112-T	500 W	12 VDC (11.4 - 12.6 VDC)	41'500 mA	90 %
TCI 500-124-T		24 VDC (22.8 - 25.2 VDC)	20'800 mA	91 %
TCI 500-148-T		48 VDC (45.6 - 50.4 VDC)	10'410 mA	92 %

Options	
TCI 500-AUX	- Optional Cable: <a href="http://www.tracopower.com/overview/tci500-aux">www.tracopower.com/overview/tci500-aux</a>
TCI-AC1	- Optional Cable: <a href="http://www.tracopower.com/overview/tci-ac1">www.tracopower.com/overview/tci-ac1</a>

### Input Specifications

Input Voltage	- AC Range	Operational Range: <b>90 - 264 VAC</b> (Full Range) Rated Range: <b>100 - 240 VAC</b> (Full Range)
	- DC Range	Operational Range: <b>127 - 370 VDC</b> (Designed for, no certification) Polarity: <b>irrelevant</b>
Input Frequency		Operational Range: <b>47 - 63 Hz</b> Certified: <b>50/60 Hz</b>
Power Consumption	- No load & Vin = 230 VAC - No load & Vin = 115 VAC	<b>500 mW max.</b> (Ready to meet ErP directive) <b>500 mW max.</b>
Input Current	- Full load & Vin = 230 VAC - Full load & Vin = 115 VAC	<b>3'150 mA max.</b> <b>6'300 mA max.</b>
Input Inrush Current	- At 230 VAC - At 115 VAC	<b>80 A max.</b> <b>40 A max.</b>
Power Factor	- At 230 VAC - At 115 VAC	<b>0.94 min.</b> (Active Power Factor Correction) <b>0.94 min.</b> (Active Power Factor Correction)
Input Protection		<b>T 10 A / 250 VAC</b> (Internal Fuse in L & N)
Recommended Input Fuse		(The need of an external fuse has to be assessed in the final application.)

### Output Specifications

Output Voltage Adjustment		<b>±5%</b> (By trim potentiometer) Output power must not exceed rated power!
Voltage Set Accuracy		<b>±2% max.</b>
Regulation	- Input Variation (Vmin - Vmax) - Load Variation (10 - 100%)	<b>1% max.</b> <b>1% max.</b>
Ripple and Noise (20 MHz Bandwidth)		12 VDC model: <b>160 mVp-p max.</b> (w/ 0.1 µF ceramic    47 µF KY) 24 VDC model: <b>240 mVp-p max.</b> (w/ 0.1 µF ceramic    47 µF KY) 48 VDC model: <b>480 mVp-p max.</b> (w/ 0.1 µF ceramic    47 µF KY)
Capacitive Load		12 VDC model: <b>5'000 µF max.</b> 24 VDC model: <b>2'500 µF max.</b> 48 VDC model: <b>1'250 µF max.</b>
Minimum Load		<b>1 % of Iout max.</b> (Operation at lower load will not damage the converter, but it may not meet all specifications)
Temperature Coefficient		<b>±0.06 %/K max.</b> (-30°C - 0°C) <b>±0.03 %/K max.</b> (0°C - 50°C)
Hold-up Time	- At 230 VAC - At 115 VAC	<b>8 ms min.</b> <b>8 ms min.</b>
Start-up Time	- At 230 VAC - At 115 VAC	<b>350 ms max.</b> <b>350 ms max.</b>
Short Circuit Protection		<b>Continuous, Automatic recovery</b> (Level 1, nom.) <b>Latch</b> (Level 2, instantaneous high current)
Output Current Limitation		<b>113 - 161% of Iout max.</b>
Overvoltage Protection		<b>111 - 130% of Vout nom.</b>
Transient Response	- Response Deviation - Response Time	<b>3% typ. / 5% max.</b> (25% to 100% Load Step) <b>2'000 µs typ. / 3'000 µs max.</b> (25% to 100% Load Step)

### Safety Specifications

Standards	- IT / Multimedia Equipment	<b>EN 62368-1</b> <b>IEC 62368-1</b> <b>UL 62368-1</b>
	- Certification Documents	<a href="http://www.tracopower.com/overview/tci500">www.tracopower.com/overview/tci500</a>
Protection Class		<b>Class I</b> (Prepared): <b>Connection to PE</b>

All specifications valid at 230 VAC, resistive full load and +25°C after warm-up time, unless otherwise stated.

Pollution Degree	PD 2
Over Voltage Category	OVC II OVC III

### EMC Specifications

EMI (Emissions)	- Conducted Emissions	EN 55032 class B (internal filter)
	- Radiated Emissions	EN 55032 class A (internal filter)
	- Harmonic Current Emissions	EN 61000-3-2, class A
EMS (Immunity)		EN 55035 (Multimedia)
	- Electrostatic Discharge	Air: EN 61000-4-2, $\pm 8$ kV, perf. criteria A Contact: EN 61000-4-2, $\pm 4$ kV, perf. criteria A
	- RF Electromagnetic Field	EN 61000-4-3, 3 V/m, perf. criteria A
	- EFT (Burst) / Surge	EN 61000-4-4, $\pm 1$ kV, perf. criteria A
		L to L: EN 61000-4-5, $\pm 1$ kV, perf. criteria A
		L to PE: EN 61000-4-5, $\pm 2$ kV, perf. criteria A
	- Conducted RF Disturbances	EN 61000-4-6, 3 Vrms, perf. criteria A
	- PF Magnetic Field	Continuous: EN 61000-4-8, 1 A/m, perf. criteria A
	- Voltage Dips & Interruptions	230 VAC / 50 Hz: EN 61000-4-11 30%, 25 periods, perf. criteria A >95%, 250 periods, perf. criteria B
		115 VAC / 60 Hz: EN 61000-4-11 30%, 25 periods, perf. criteria A >95%, 250 periods, perf. criteria B
EMC / Environmental	- Certification Documents	<a href="http://www.tracopower.com/overview/tci500">www.tracopower.com/overview/tci500</a>

### General Specifications

Relative Humidity		95% max. (non condensing)
Temperature Ranges	- Operating Temperature	-30°C to +70°C
	- Storage Temperature	-30°C to +85°C
Power Derating	- High Temperature	2 %/K above 50°C
	- Low Input Voltage	3 %/V below 100 VAC
	See application note:	<a href="http://www.tracopower.com/overview/tci500">www.tracopower.com/overview/tci500</a>
Over Temperature Protection Switch Off	- Protection Mode	115°C min. / 120°C typ. / 125°C max. (Automatic recovery at 90°C typ.)
	- Measurement Point	Internal IC temperature
Cooling System		Forced air cooling (with internal fan)
Fan Power Source	- Characteristic	Variable fan speed (load regulated)
	- Output Voltage	12 VDC
	- Output Current	209 mA max. (Fan output voltage: 10.2 - 13.3 VDC when main output load > 3% and fan current > 0.1 mA)
Standby Power Source	- Output Voltage	5 VDC
	- Output Current	1 A max.
Remote Control	- Voltage Controlled Remote (passive = on)	On: 3.3 to 5 VDC or open circuit Off: 0 to 1.0 VDC or short circuit
	- Off Idle Input Current	Refers to '+Remote' and '-Remote' Pin 92 mA typ. / 155 mA max.
	- Remote Pin Input Current	8 to 30 mA
Altitude During Operation		4'000 m max. (for OVC III)
		5'000 m max. (for OVC II)
Regulator Topology		LCC Converter
Switching Frequency		58 - 76 kHz (PFM)
		67 kHz typ. (PFM)
Insulation System		Reinforced Insulation
Working Voltage (rated)		277 VAC

All specifications valid at 230 VAC, resistive full load and +25°C after warm-up time, unless otherwise stated.

Isolation Test Voltage	- Input to Output, 60 s	4'250 VAC (6'000 VDC)
	- Input to Case or PE, 60 s	2'830 VAC (4'000 VDC)
	- Output to Case or PE, 60 s	1'500 VAC (2'121 VDC)
Isolation Resistance	- Input to Output, 500 VDC	100 MΩ min.
Leakage Current (at 264 VAC / 63 Hz)	- Earth Leakage Current	1500 μA max.
Distance Through Isolation		7.1 mm
Reliability	- Calculated MTBF	160'000 h (MIL-HDBK-217F, ground benign)
Washing Process		Not allowed
Environment	- Vibration	IEC 60068-2-6 2 g, 3 axis, 60 min, 10-500 Hz, 10 min/cycle
	- Mechanical Shock	IEC 60068-2-27 50 g, 3 axis, half sine, 11 ms
Housing Material		Aluminum
Potting Material		Silicone (UL 94 V-0 rated) (the converter is partly potted on the bottom)
Housing Type		Metal Case
Mounting Type		Chassis Mount
Connection Type		Screw Terminal, Pin Connector
Weight		710 g
Power OK Signal		Voltage source output
	- Power OK	High level
	- Power Off	Low level (Refers to 'PG' and 'GND' Pin)
Status Indicator		Indicated by green LED
Sense Function		3% max. of Vout nom.
Environmental Compliance	- REACH Declaration	<a href="http://www.tracopower.com/info/reach-declaration.pdf">www.tracopower.com/info/reach-declaration.pdf</a> REACH SVHC list compliant REACH Annex XVII compliant
	- RoHS Declaration	<a href="http://www.tracopower.com/info/rohs-declaration.pdf">www.tracopower.com/info/rohs-declaration.pdf</a> Exemptions: 7a, 7c-1 (RoHS exemptions refer to the component concentration only, not to the overall concentration in the product (O5A rule).)
	- SCIP Reference Number	1dab86cb-c6c6-4c4f-9524-9695b51a1299

## Supporting Documents

Overview Link (for additional Documents)

[www.tracopower.com/overview/tci500](http://www.tracopower.com/overview/tci500)

All specifications valid at 230 VAC, resistive full load and +25°C after warm-up time, unless otherwise stated.

### Outline Dimensions

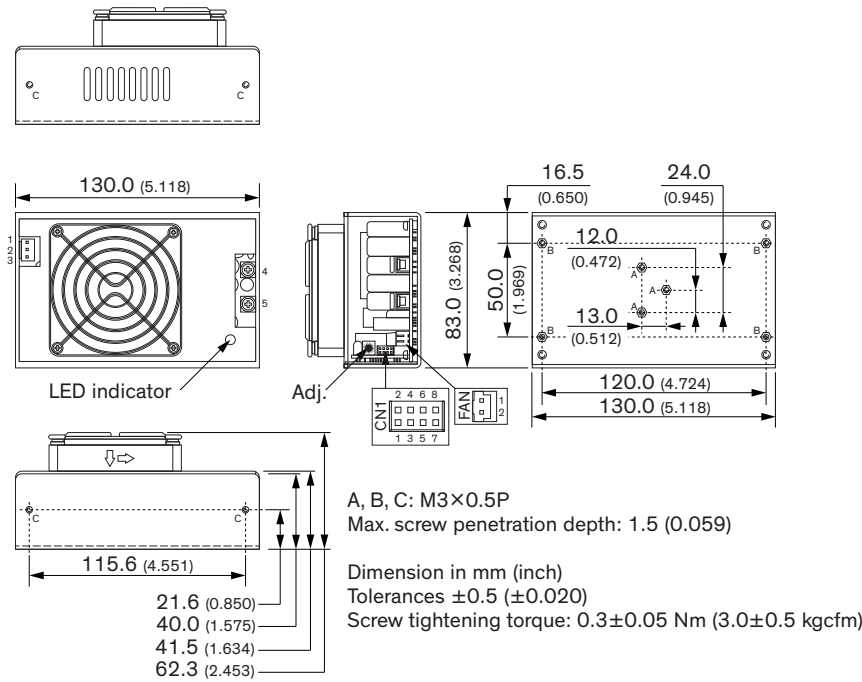

Input	
Pin	Function
1	AC (N)
2	No Pin
3	AC (L)

Output	
Pin	Function
4	+Vout
5	-Vout**

Auxiliary	
CN1	
Pin	Function
1	-Standby**
2	+Standby
3	GND
4	Power Good
5	-Remote**
6	+Remote
7	-Sense**
8	+Sense

FAN	
Pin	Function
1	+12V
2	GND

Case	
(no dedicated connector)	
Pos	Function
A	For mounting on chassis only
B	For mounting on PCB or chassis, and connecting PE
C	For connecting PE only

\*\*Internally connected with GND

**Input:** JST series  
mates with JST crimp terminal: SVH-41T-P1.1 or Equivalent  
and terminal housing: VHR-3N or Equivalent

**Output:** Screw Terminal  
M3.5 Pozzi Pan Head Screw  
max. torque: 0.9 Nm (9.1 kgcfm)

**Auxiliary:** JST series  
mates with JST crimp terminal: SPHD-001T-P0.5 or Equivalent  
and terminal housing: PHDR-08VS or Equivalent

**FAN:** JST series  
mates with JST crimp terminal: SXH-002T-P0.6 or Equivalent  
and terminal housing: XHP-2 or Equivalent