

40W

Convection cooled

AC-DC power supplies

The ECF40 series is designed to minimize the no load power consumption and maximize efficiency to facilitate equipment design to meet the latest environmental legislation. Approved for medical (2 x MOPP) and ITE applications in either Class I or Class II installations and has two AC line fuses and low leakage currents required by medical applications.

This range of single output AC-DC power supplies are packaged in a low profile 28.0mm height with a foot print of just 76.2 x 38.1mm. The ECF40 provides up to 40W convection-cooled over the full 90-264VAC input range, and operates down to 80VAC with minimal de-rating. The low profile, low noise and safety approvals covering ITE and medical standards allows the versatile series to be used in a wide range of applications.



Features

- ▶ 40W convection cooled
- ▶ 76.2 x 38.1mm (3" x 1.5") footprint, 28.0mm profile
- ▶ Regulated single outputs 12 to 48VDC
- ▶ Input range 80 to 264VAC
- ▶ Medical (2 x MOPP) & ITE approvals
- ▶ Class I & Class II installations
- ▶ Less than 0.15W no load input power
- ▶ 3 year warranty

Applications

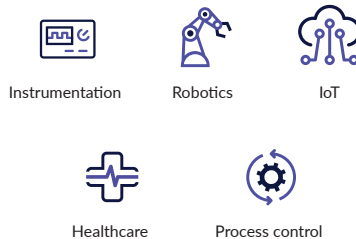

Dimensions

76.2 x 38.1 x 28.0mm (3.00" x 1.50" x 1.10")

Models & ratings

Model number ⁽²⁾	Output voltage	Output current	Efficiency	Output power
ECF40US12	12.0VDC	3.34A	91%	40W
ECF40US15	15.0VDC	2.67A	92%	40W
ECF40US18	18.0VDC	2.23A	93%	40W
ECF40US24	24.0VDC	1.67A	91%	40W
ECF40US36	36.0VDC	1.11A	90%	40W
ECF40US48	48.0VDC	0.83A	90%	40W

Notes:

1. Typical efficiency measured at full load and 230VAC input.

Input

Characteristic	Minimum	Typical	Maximum	Units	Notes & conditions
Input voltage range	80	115/230	264	VAC	Derate output from 100% at 90VAC to 90% at 85VAC and 80% at 80VAC
Input frequency	47	50/60	63	Hz	Agency approval, 47-63Hz
No load input power			0.15	W	
Inrush current			70	A	264VAC cold start, 25°C
Earth leakage current			250	μA	264VAC/60Hz
Input protection	T3.15A/250A, 250V Internal fuse fitted in line and neutral.				
Power factor	EN61000-3-2 Class A				

Output

Characteristic	Minimum	Typical	Maximum	Units	Notes & conditions
Output voltage	12		48	48	See models and ratings
Initial set accuracy			±1	%	50% load, 115/230VAC
Output voltage adjustment	10				
Minimum load	No minimum load required				
Line regulation			±0.5	%	90-264VAC
Load regulation			1		0-100% load.
Start up delay		1	2	s	
Start up rise time		50		ms	
Hold up time	8.3/20				At full load and 115VAC
Transient response			4	%	Recovery within 1% in less than 500μs for a 50-75% and 75-50% load step
Ripple & noise			3/2	% pk-pk	12V/15-48V models
Overvoltage protection	115		140	% Vnom	Vnom, recycle input to reset
Overload protection	140		160	%	Of total power
Over/undershoot			5	%/°C	
Short circuit protection	Continuous trip & restart (hiccup mode)				
Temperature coefficient			0.05	%/°C	

General

Characteristic	Minimum	Typical	Maximum	Units	Notes & Conditions
Efficiency	See models & ratings				
Isolation	4000			VAC	Input to output (2 MOPP)
	1500				Input to ground (1 MOPP)
	500				Output to ground (1 MOPP at output voltage)
Switching frequency				kHz	
Power density			0.4 (8.1)	W/cm ³ (W/in ³)	PCB mount version
Mean time between failure	500			khrs	MIL-HDBK-217F, Notice 2 +25°C GB
Weight		69.0 (0.15)		g (lbs)	

Environmental

Characteristic	Minimum	Typical	Maximum	Units	Notes & conditions
Operating temperature	-20		+70	°C	See derating curve
Storage temperature	-40		+85	°C	
Cooling	Convection-cooled				
Humidity			95	%RH	Non-condensing
Operating altitude			5000/4000	m	ITE/Medical
Shock	±3 x 30g shocks in each plane, total 18 shocks. 30g = 11ms (±0.5msecs), half sine. Conforms to EN60068-2-27				
Vibration	Single axis 10-500Hz at 2g sweep and endurance at resonance in all 3 planes. Conforms to EN60068-2-6				

Emissions - EMC

Phenomenon	Standard	Test level	Notes & conditions
Conducted	EN55011/32	Class B	
Radiated	EN55011/32	Class A	
Harmonic current	EN61000-3-2	Class A	
Voltage flicker	EN61000-3-3		

Safety approvals

Certification	Standard	Notes & conditions
CB	IEC60950-1, IEC62368-1	Information technology
	IEC60601-1 Ed 3.1 Including Risk Management	Medical
UL	UL62368-1 2nd Ed., CSA C22.2 No. 62368-1-14	Information technology
	ANSI/AAMI ES60601-1: & CSA C22.2 No.6061-1:08	Medical
EN	EN62368-1	Information technology
	EN60601-1	Medical
CE	Meets all applicable directives	
UKCA	Meets all applicable legislation	

Emissions - Immunity

Phenomenon	Standard	Test level	Criteria	Notes & conditions
Medical device EMC	IEC60601-1-2	Ed.4.0 : 2014	as below	
Low voltage PSU EMC	EN61204-3	High severity level	as below	
ESD	EN61000-4-2	±8kV contact, ±15kV air	A	
Radiated	EN61000-4-3	3	A	
EFT	EN61000-4-4	3	A	
Surge	EN61000-4-5	Installation class 3	A	
Conducted	EN61000-4-6	3	A	
Magnetic fields	EN61000-4-8	4	A	
Dips and interruptions	EN61000-4-11 (100VAC)	Dip 100% (0VAC), 8.4ms	A	25% derating
		Dip 100% (0VAC), 16.7ms	B	
		Dip 60% (40VAC), 200ms	B	
		Dip 30% (70VAC), 500ms	B	
		Dip 20% (80VAC), 5000ms	B	
		Int 100% (0VAC), 5000ms	B	
	EN61000-4-11 (115VAC)	Dip 100% (0VAC), 8.4ms	A	
		Dip 100% (0VAC), 16.7ms	B	
		Dip 60% (40VAC), 200ms	B	
		Dip 30% (70VAC), 500ms	B	
		Dip 20% (80VAC), 5000ms	B	
		Int 100% (0VAC), 5000ms	B	
	EN61000-4-11 (240VAC)	Dip 100% (0VAC), 10ms	A	
		Dip 100% (0VAC), 20ms	B	
		Dip 60% (96VAC), 200ms	B	
		Dip 30% (168VAC), 500ms	B	
		Dip 20% (192VAC), 5000ms	B	
		Int 100% (0VAC), 5000ms	B	
	EN60601-1-2 (100VAC)	Dip 100% (0VAC), 10ms	A	30% derating
		Dip 100% (0VAC), 20ms	A	60% derating
		Dip 60% (40VAC), 100ms	A	75% derating
		Dip 30% (70VAC), 500ms	A	
		Int 100% (0VAC), 5000ms	B	
	EN60601-1-2 (240VAC)	Dip 100% (0VAC), 10ms	A	
Dip 100% (0VAC), 20ms		A		
Dip 60% (96VAC), 100ms		A		
Dip 30% (168VAC), 500ms		A		
Int 100% (0VAC), 5000ms		B		

Application notes

Efficiency vs load

ECF40US12

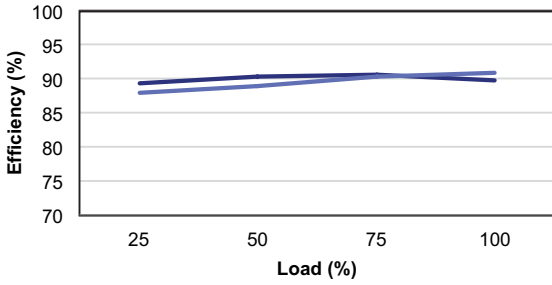

ECF40US24

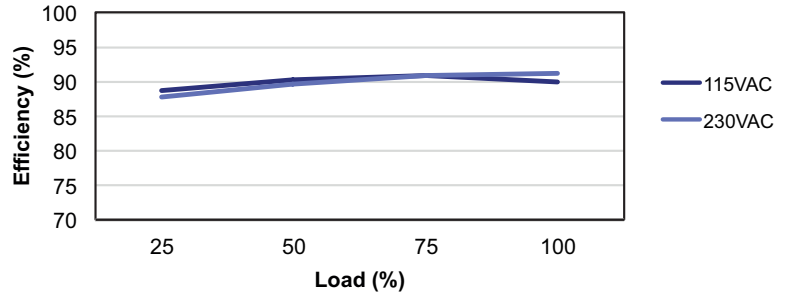

Temperature derating curve

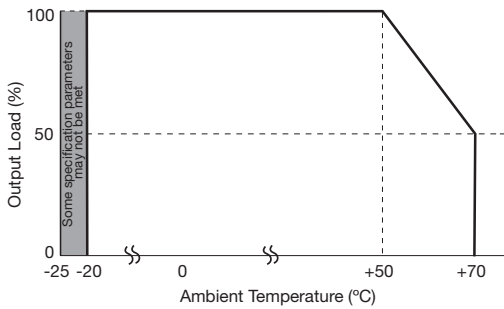

Thermal considerations

In order to ensure safe operation of the PSU in the end-use equipment, the temperature of the components listed in the table below must not be exceeded. Temperature should be monitored using thermocouples placed on the hottest part of the component (out of direct air flow). See mechanical details for component locations.

Temperature measurements (at maximum ambient)	
Component	Max temperature (°C)
TR1 coil	120°C
L1 coil	120°C
C2	105°C
C13	105°C
C14	105°C

Application notes

Service life

The estimated service life of the ECF40 is determined by the cooling arrangements and load conditions experienced in the end application. Due to the uncertain nature of the end application this estimated service life is based on the actual measured temperature of key capacitors within the product when installed by the end application. The graph below expresses the estimated lifetime based on the temperature of these key components based on the average temperature over the lifetime of the equipment.

Estimate service life vs component temperature

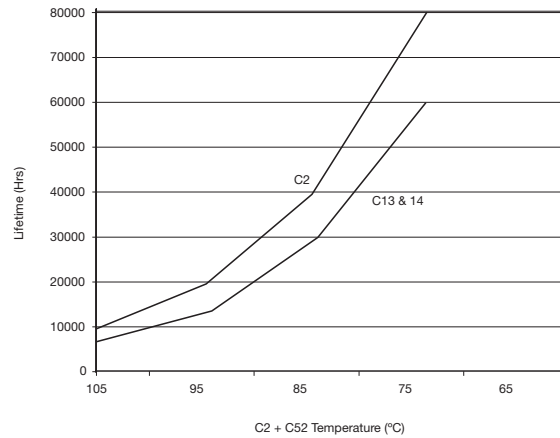

Mechanical details

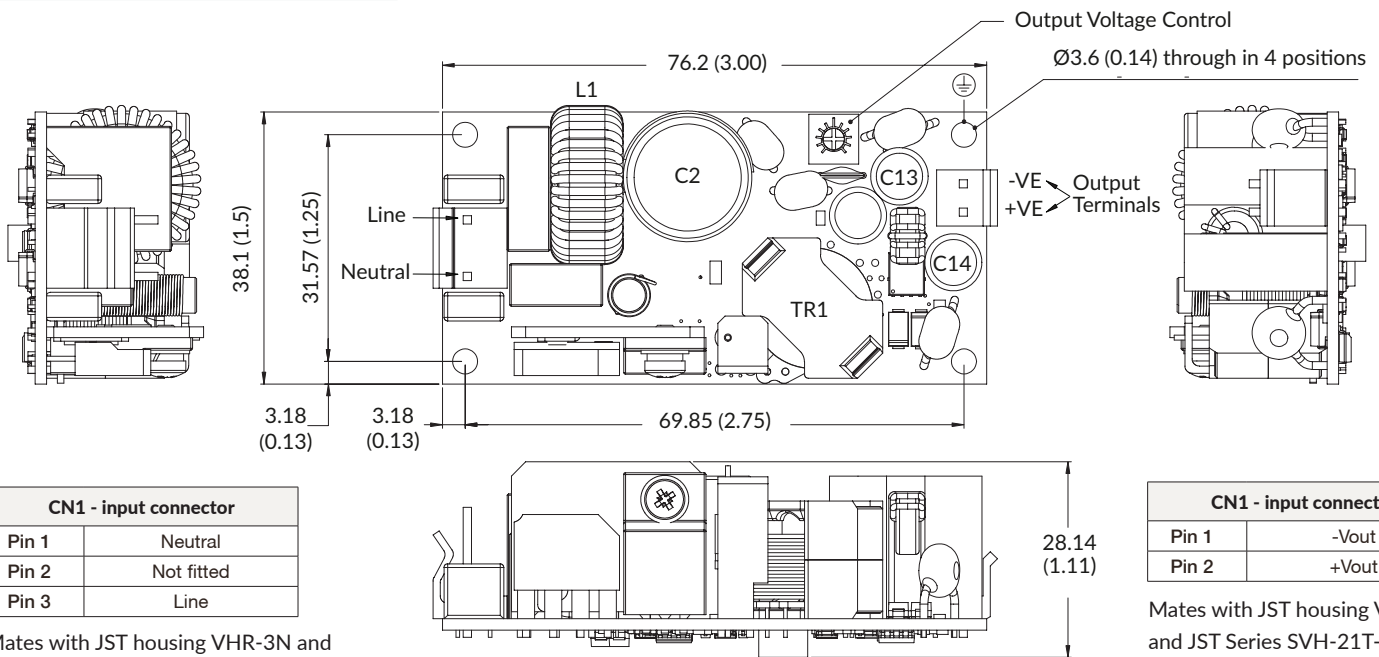

CN1 - input connector	
Pin 1	Neutral
Pin 2	Not fitted
Pin 3	Line

Mates with JST housing VHR-3N and JST Series SVH-21T-P1.1 crimp terminals

CN1 - input connector	
Pin 1	-Vout
Pin 2	+Vout

Mates with JST housing VHR-3N and JST Series SVH-21T-P1.1 crimp terminals

Mounting hole marked with \oplus must be connected to safety earth for class I applications

Notes:

1. All dimensions in mm (inches).

2. Weight: 66g (0.14lb)

Specifications subject to change without notice.