

15W

AC-DC
power supplies

The ECL15 series is a range of single, dual and triple output AC-DC power supplies that delivers 15W of power and offers dual output voltages ranging from 3.3V to 48V. The ECL15 series can be supplied as PCB mount open frame (suffix -P), PCB mount encapsulated (suffix -E), open frame chassis mount (suffix -T), or as encapsulated chassis mount with screw terminals (suffix -S) with an optional DIN clip (suffix -SD). The ECL15 has IEC Class II construction and a no-load input power less than 0.3W.

The ECL15 series, with worldwide ITE safety approvals, Class B conducted and radiated emissions, IEC Class II insulation, and 3kVAC isolation, is ideal for a wide range of industrial and analytical instrumentation applications including test and measurement, process control, factory automation, communications and other ITE applications.



Features

- ▶ Regulated single outputs from 3.3V to 48VDC
- ▶ Regulated dual outputs +5V +12VDC, ±12V & ±15VDC
- ▶ Regulated triple outputs +5V ±12V & +5V ±15VDC
- ▶ Universal input range 85-264VAC
- ▶ 3kVAC input to output isolation
- ▶ <0.3W no load input power
- ▶ EN55032 Class B conducted and radiated emissions
- ▶ IEC62368-1 ITE safety agency approvals
- ▶ IEC Class II insulation rating
- ▶ Overvoltage, overload, and short circuit protection
- ▶ -20°C to +70°C operating temperature
- ▶ 3 year warranty

Applications

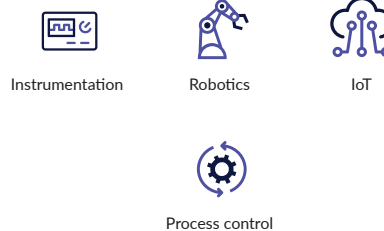

Dimensions

ECL15-P

62.0 x 30.7 x 20.0mm (2.44" x 1.21" x 0.78")

ECL15-E

65.0 x 33.3 x 24.4mm (2.56" x 1.31" x 0.96")

ECL15-T

78.7 x 31.7 x 20.0mm (3.10" x 1.25" x 0.78")

ECL15-S

84.0 x 34.5 x 26.4mm (3.30" x 1.36" x 1.04")

Models & ratings

Model number ⁽²⁾	Output voltage	Output current		Efficiency	Output power
		Nominal	Peak ⁽¹⁾		
ECL15US03	3.3VDC	3.00A	3.90 A	75%	10.0W
ECL15US05	5.0VDC	3.00A	3.90A	78%	15.0W
ECL15US09	9.0VDC	1.67A	2.17A	80%	15.0W
ECL15US12	12.0VDC	1.25A	1.62A	80%	15.0W
ECL15US15	15.0VDC	1.00A	1.30A	80%	15.0W
ECL15US24	24.0VDC	0.63A	0.82A	82%	15.0W
ECL15US48	48.0VDC	0.32A	0.41A	82%	15.0W

Notes:

1. Peak load lasting <30s with a maximum duty cycle of 10%, average output power not to exceed nominal.
2. Add suffix to model number to define type: add '-P' for PCB mount, add '-T' for chassis mount, add '-E' for encapsulated, add '-S' for screw terminals.
3. A screw terminal version (-S) is available with DIN clip attached, add suffix 'D', e.g. ECL15US24-SD, DIN rail mounting kit is available as a separate item, order code ECL15 DIN CLIP.
4. For medically-approved 15 W power supplies contact sales or see www.xppower.com for details of EML15 series.

Models & ratings - ECL15UD/UT

Model number ^(3,4)	Output 1		Output 2		Output 3		Efficiency	Output power
	Voltage	Current ⁽²⁾	Voltage	Current ⁽²⁾	Voltage	Current ⁽²⁾		
ECL15UD01	+12.00V	0.65A	-12.00V	0.65A			82%	15.0W
ECL15UD02	+15.00V	0.50A	-15.00V	0.50A			82%	15.0W
ECL15UD03	5.00V ⁽¹⁾	1.50A	12.00V ⁽¹⁾	0.625A			81%	15.0W
ECL15UT02	5.00V ⁽¹⁾	2.00A	+12.00V	0.20A	-12.00V	0.20A	81%	15.0W
ECL15UT03	5.00V ⁽¹⁾	2.00A	+15.00V	0.15A	-15.00V	0.15A	81%	15.0W

Notes:

1. Isolated output
2. Peak load of 130% lasting <30s with a maximum duty cycle of 10%, average output power not to exceed nominal.
3. Add suffix to model number to define type: add '-P' for PCB mount, add '-T' for chassis mount, add '-E' for encapsulated, add '-S' for screw terminals.
4. A screw terminal version (-S) is available with DIN clip attached, add suffix 'D' e.g. ECL15UT02-SD, DIN rail mounting kit is available as a separate item, order code ECL15 DIN CLIP.

Input

Characteristic	Minimum	Typical	Maximum	Units	Notes & conditions
Input voltage range	85		264	VAC	
	120		370	VDC	
Input frequency	47		63	Hz	
Input current		0.3		A rms	At 230VAC
No load input power			<0.3	W	
Inrush current			20	A	At 115VAC, cold start at 25°C
			40	A	At 230VAC, cold start at 25°C
Earth leakage current					Class II construction no earth
Input protection	Internal T2A/250 VAC fuse				
Power factor	EN61000-3-2 Class A				

General

Characteristic	Minimum	Typical	Maximum	Units	Notes & conditions
Efficiency	75		82	%	See Models & Ratings
Isolation: input to output	3000			VAC	
Switching frequency		70		kHz	
Power density			86.85 (5.30)	W/cm ³ (W/in ³)	PCB mount version
Mean time between failure	>400			khrs	MIL-HDBK-217F, +25°C GB
Weight		35 (0.07)		g (lb)	ECL15-P
		35 (0.07)			ECL15-T
		90 (0.20)			ECL15-E
		110 (0.24)			ECL15-S
		40 (0.09)			ECL15-P (UD/UT)
		40 (0.09)			ECL15-T (UD/UT)
		95 (0.21)			ECL15-E (UD/UT)
		120 (0.26)			ECL15-S (UD/UT)

Output

Characteristic	Minimum	Typical	Maximum	Units	Notes & conditions
Output voltage	3.3		48	VDC	
Output voltage trim		±5		%	On output 1 only, on multiple output versions, V2 & V3 will track by same percentage, (not '-E' or '-S' versions)
Initial set accuracy			±1	%	For output 1
			±1		For output 2 of UD01 & UD02 versions
			±5		For output 2 & output 3 of other versions
Minimum load	Single output versions: none Multi output versions: UD01 & UD02: 10% V1 & V2, UD03: 10% V1, 20% V2, UT02 & UT03: 10% V1, 20% V2 & V3 to meet regulation specifications				
Line regulation			±0.5	%	For single output versions and output 1 of multiple output versions
			±0.9		For output 2 & output 3 of multiple output versions
Load regulation		<3%		%	UD01/UD02, 10-100% load
		<1% (V1) <10% (V2)			UD03
		1% V1 <10% V2 & V3			UT02/UT03
Cross regulation		<3%		%	UD01/UD02, one output fixed, the other varied from 10-100% load
		<10% V2			UD03, V1 varied from 10-100% load
		10% V2 & V3			UT02/UT03, 50% load & V1 varied from 20-100% load
Start up delay			3	s	
Start up rise time			14	ms	
Hold up time		16		ms	Single output versions
		12			Multiple output versions at full load and 115VAC
Transient response			4	%	Deviation, recovery within 1% in less than 500µs for a 25% load change
Ripple & noise			50	mV pk-pk	3.3-5V versions, 20 MHz bandwidth
			90		9V versions, 20 MHz bandwidth
			120		12-15V versions, 20 MHz bandwidth
			200		24-48V versions, 20 MHz bandwidth
	Multi output versions: 1% pk-pk on any output, 20 MHz bandwidth				
Overvoltage protection	115		140	% Vnom	3.3V
	195		216		
Overload protection	120		150	%	
Short circuit protection	Trip & restart (hiccup mode)				
Temperature coefficient			0.05	%/°C	

Environmental

Characteristic	Minimum	Typical	Maximum	Units	Notes & conditions
Operating temperature	-20		+70	°C	Derate linearly from 100% at +50°C to 50% at +70°C
Storage temperature	-40		+85	°C	
Cooling	Convection-cooled				
Humidity			95	%RH	Non-condensing
Operating altitude			3000 (9842)	m (ft)	
Vibration	2g, 10Hz to 500Hz, 10 mins/cycle, 60 mins each cycle				

Emissions - EMC

Phenomenon	Standard	Test level	Notes & conditions
Conducted	EN55032	Class B	
Radiated	EN55032	Class B	
Harmonic current	EN61000-3-2	Class A	
Voltage flicker	EN61000-3-3		

Emissions - Immunity

Phenomenon	Standard	Test Level	Criteria	Notes & conditions
ESD immunity	EN61000-4-2	3	A	
Radiated immunity	EN61000-4-3	10 V/m, 80%	A	
EFT/burst	EN61000-4-4	3	A	
Surge	EN61000-4-5	3	A	
Conducted	EN61000-4-6	10Vrms	A	
Magnetic fields	EN61000-4-8	10A/m	A	
Dips and interruptions	EN61000-4-11	30% for 10ms	A	
		60% for 100ms	B	
		100% for 5000ms	B	

Safety approvals

Certification	Standard	Notes & conditions
CB	IEC60950-1:2005 Ed 2 / IEC62368-1:2014	
UL	UL62368-1 & CAN/CSA C22.2 No. 62368- 1-14	
EN	EN62368-1	
CE	Meets all applicable directives	
UKCA	Meets all applicable legislation	

Mechanical details

Open frame - PCB mount (-P)

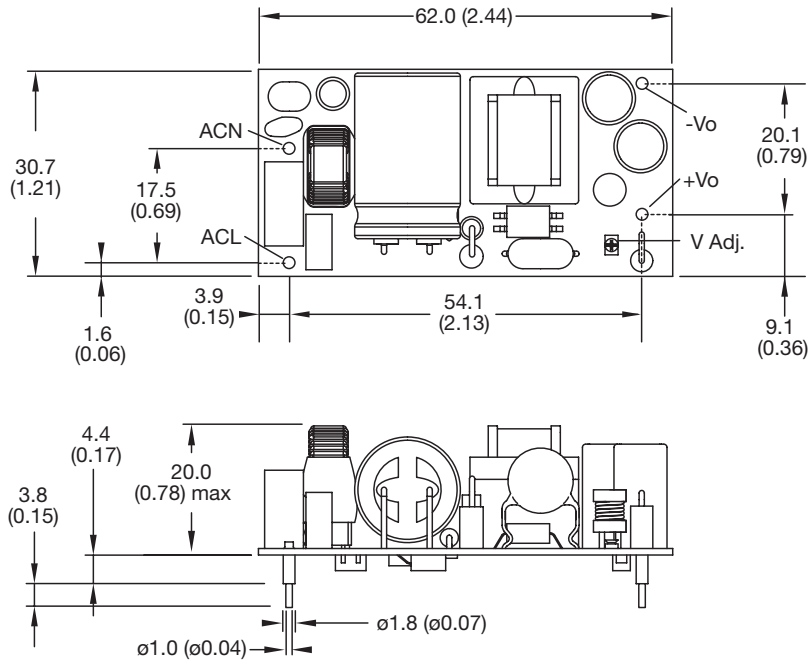

Open frame - Chassis mount (-T)

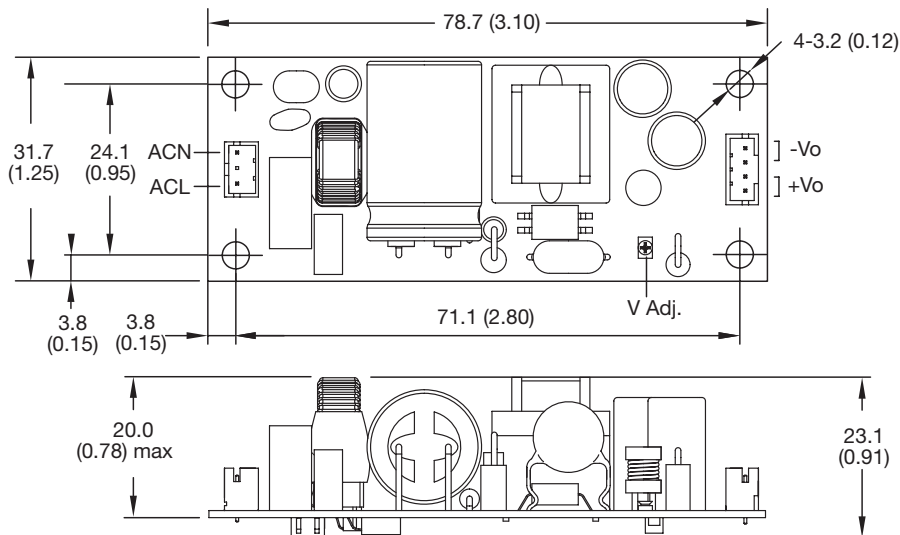

Notes:

1. All dimensions in mm (inches).
2. Tolerances: x.x (x.xx) = ± 0.5 (± 0.02), x.xx (x.xxx) = ± 0.25 (± 0.01)
3. Weight: ECL15 -P version: 35g (0.07lb); ECL15 -T version: 35g (0.07lb)

Mating Connectors (-T version only)

Input Connector: JST PHR-3

Output Connector: JST XHP-5

Mechanical details

Encapsulated (-E)

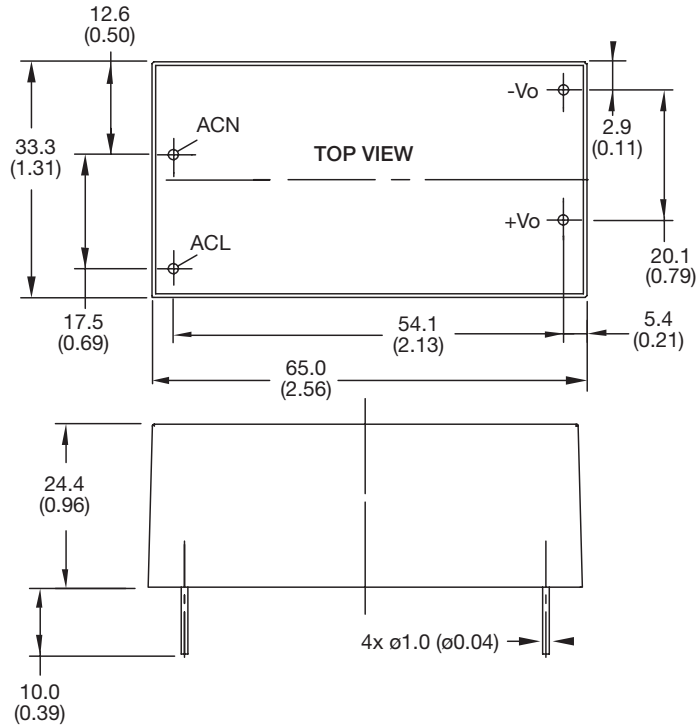

Screw terminal (-S)

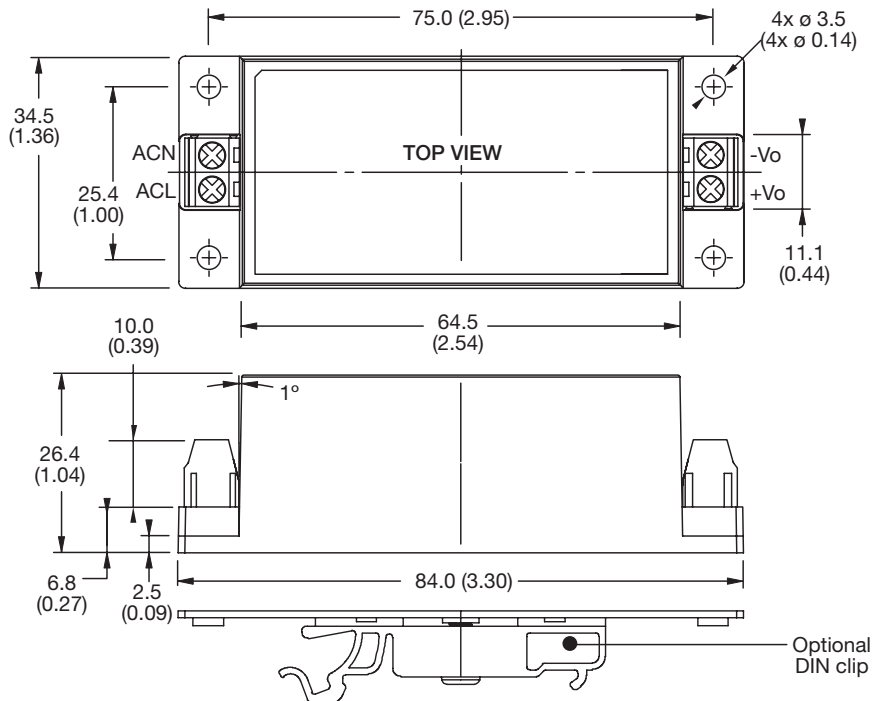

Notes:

1. All dimensions in mm (inches).
2. Tolerances: x.x (x.xx) = ± 0.5 (± 0.02), x.xx (x.xxx) = ± 0.25 (± 0.01)
3. Weight: ECL15 -E version: 90g (0.20lbs) ECL15-S Version: 110g (0.24lbs)

Mating Connectors (-T version only)

Input Connector: JST PHR-3
Output Connector: JST XHP-5

ECL15UD/UT series

Mechanical details

Open frame - PCB mount (-P)

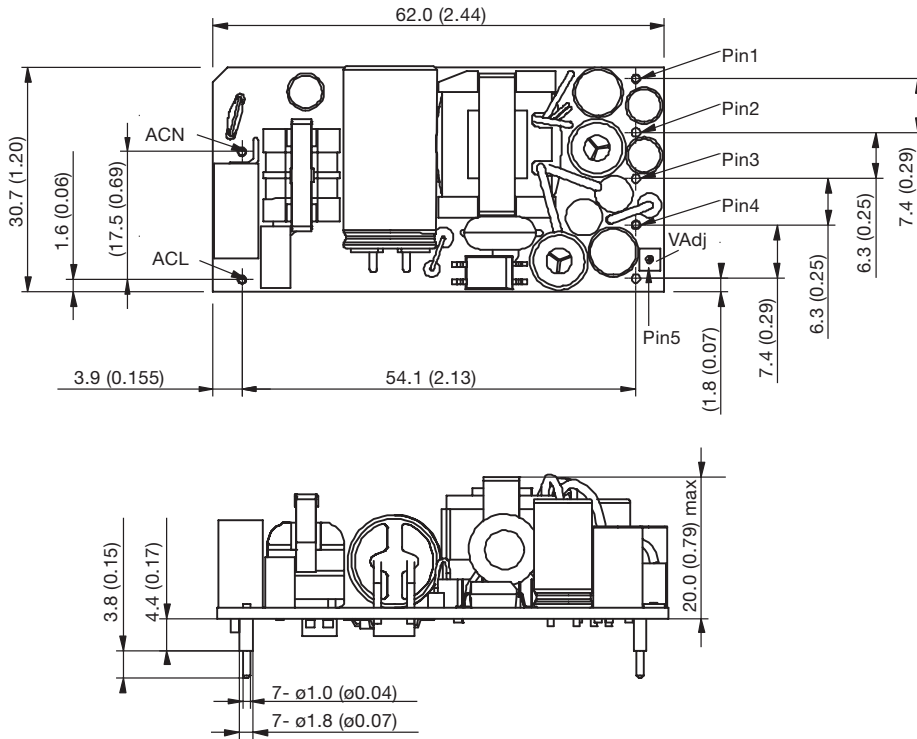

Pin	UD01/02	UD03	UT02/03
1	V2	No pin	V3
2	No pin	V2 RTN	COM
3	COM	V2	V2
4	V1	V1	V1
5	No pin	V1 RTN	V1 RTN

Open frame - Chassis mount (-T)

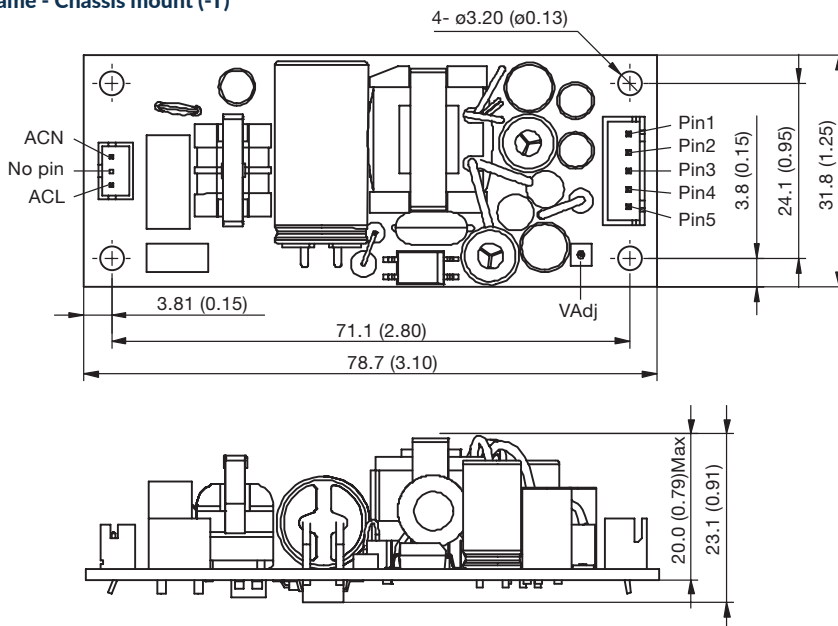

Pin	UD01/02	UD03	UT02/03
1	V2	No connection	V3
2	COM	V2 RTN	COM
3	COM	V2	V2
4	COM	V1	V1
5	V1	V1 RTN	V1 RTN

Notes:

1. All dimensions in mm (inches).
2. Tolerances: x.x (x.xx) = ± 0.5 (± 0.02), x.xx (x.xxx) = ± 0.25 (± 0.01)
3. Weight: ECL15 -P version: 40g (0.09lb); ECL15 -T version: 40g (0.09lb)

Mating Connectors (-T version only)

Input Connector: JST PHR-3
Output Connector: JST XHP-5

ECL15UD/UT series

Mechanical details

Encapsulated (-E)

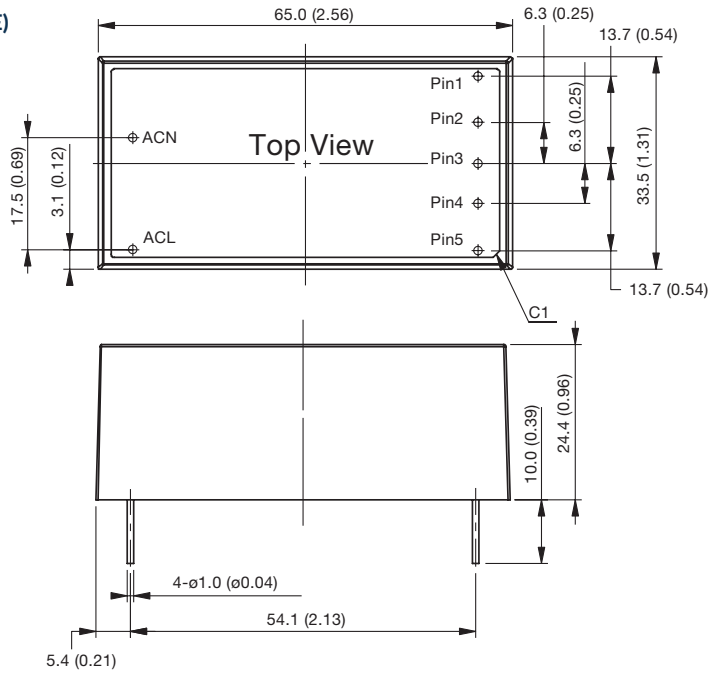

Pin	UD01/02	UD03	UT02/03
1	V2	No pin	V3
2	No pin	V2 RTN	COM
3	COM	V2	V2
4	V1	V1	V1
5	No pin	V1 RTN	V1 RTN

Screw terminal (-S)

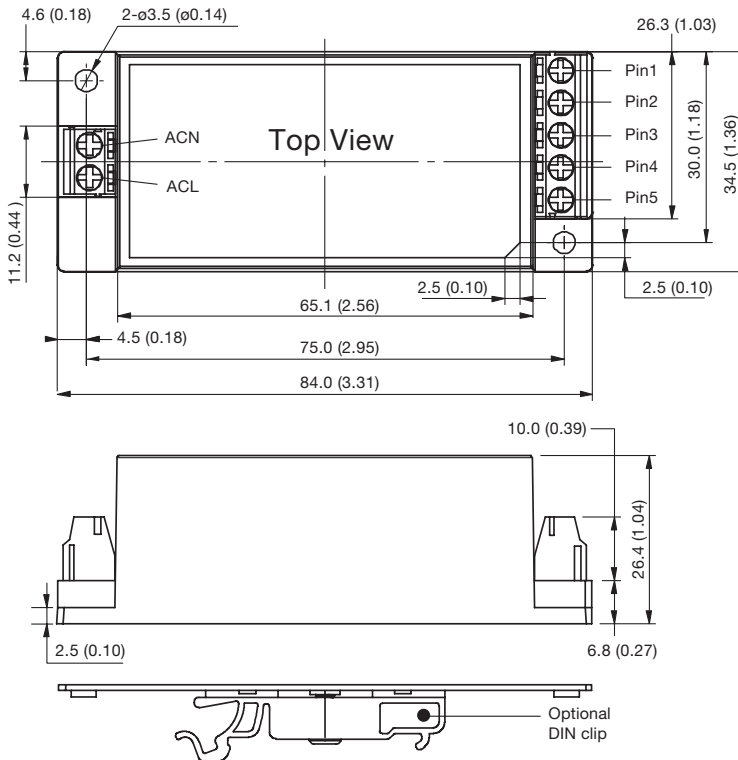

Pin	UD01/02	UD03	UT02/03
1	V2	No connection	V3
2	COM	V2 RTN	COM
3	COM	V2	V2
4	COM	+V1	V1
5	V1	V1 RTN	V1 RTN

Notes:

- All dimensions in mm (inches).
- Tolerances: x.x (x.xx) = ±0.5 (±0.02), x.xx (x.xxx) = ±0.25 (±0.01)
- Weight: ECL15 -E version: 95g (0.21lbs) ECL15-S Version: 120g (0.26 lbs)

Mating Connectors (-T version only)

Input Connector: JST PHR-3
Output Connector: JST XHP-5

Specifications subject to change without notice.