

**5kW** Fan cooled

AC-DC power supplies

The HPL5K0 series offers ultimate flexibility with both output voltage and output current programming and user defined signals, warnings and alarms. Programming is via voltage, I<sup>2</sup>C PMBus, RS485 and CANopen in a very high efficiency, high power density 5kW chassis mount package. The HPL5K0 can be used in both constant voltage and constant current operation.

Measuring just 13.0" x 5.0" x 5.0", the HPL5K0 also features active current sharing, remote on/off, remote sense and a power OK signal. The 5V/2A standby output is available whenever the mains supply is present.



## Features

- ▶ 3 Phase 180 to 264VAC input - 3 wire & earth
- ▶ High efficiency - up to 93%
- ▶ Programmable output voltage (0-105%)
- ▶ Programmable output current (0-110%)
- ▶ Parallel operation
- ▶ Analog and digital interfaces
- ▶ Multiple digital protocols - PMBus, CANopen, MODBUS & SCPI
- ▶ Fully featured signals & controls
- ▶ 5V/2A standby output
- ▶ Graphical user interface (GUI)
- ▶ SEMI F47 compliant
- ▶ 3 year warranty

## Applications

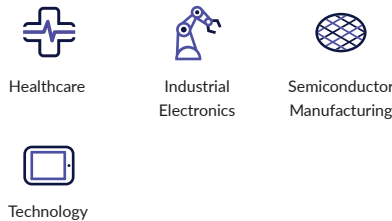

## Dimensions

330.2 x 127.0 x 127.0mm (13.00 x 5.00 x 5.00")

## Models & ratings

Model number <sup>(1)</sup>	Max output power	Output voltage V1			Output current		Efficiency <sup>(2)</sup>
		Minimum	Nominal	Maximum	Minimum	Maximum	
HPL5K0TS048	5kW	0 VDC	48 VDC	50.4 VDC	0.0A	104.0 A	92%
HPL5K0TS060	5kW	0 VDC	60 VDC	63.0 VDC	0.0A	83.3 A	92%
HPL5K0TS100	5kW	0 VDC	100 VDC	105.0 VDC	0.0A	50.0 A	92%
HPL5K0TS200	5kW	0 VDC	200 VDC	210.0 VDC	0.0A	25.0 A	92%

### Notes:

1. Standard models include PMBus, CANopen and RS485 interfaces. RS485 default is full duplex. RS485 half duplex can be configured via I<sup>2</sup>C or factory configured on request.
2. Measured with 180 VAC input and full load.
3. USB host adaptor available, converting to I<sup>2</sup>C, CANbus and RS485. Works with application download: XP PS Manager. Contact sales for kit: I<sup>2</sup>C-USB

## Input

Characteristic	Minimum	Typical	Maximum	Units	Notes & conditions
Input voltage	180		264	VAC	5kW output power max, 3 wire & earth
Input frequency	47		63	Hz	
Power factor		0.98			Complies with EN61000-3-2 for Class A
Input current			18	A	Per phase, 180VAC (5 kW)
Inrush current			60	A	Per phase, 264VAC (5 kW), cold start 25°C
Earth leakage current			1.0	mA	264VAC/60Hz
			3.3		264VAC/60Hz, single fault
Input protection	F25A / 250V fuse fitted in each phase				
Loss of phase	Shut down after 0.5s, auto-recovery				

## Output

Characteristic	Minimum	Typical	Maximum	Units	Notes & conditions
Output voltage	0		210	VDC	See Models and ratings table
Output set tolerance		±0.5		%	Nominal voltage irrespective of set voltage.
+5 V standby tolerance		±3		%	5V/2A Standby
Output voltage program	0		105	%	Of nominal, slew rate <40ms 10-105% & 105-10%. Max frequency of voltage program is 0.5Hz 0-5% load, 0.67Hz 5-10% load, 1Hz 10-20% load, 3Hz 20-100% load
Output voltage adjust	±10			%	Of set output via potentiometer 105% of nominal max.
Output current program	0		110	%	Of nominal
Minimum load	0			A	No minimum load required
Start up delay		1.8	2.3	s	Under all load and line conditions
Start up rise time			40	ms	
Hold up time	20	22		ms	208VAC at 5000 W and 25°C
Line regulation			±0.5	%	Of nominal voltage
			±0.5		5V/2A Standby
Load regulation			1	%	0-100% or 100-0% load
			2		5V/2A Standby
Transient response			3	%	Deviation with a 50-75-50% load change. Output returns to within 1% in less than 500µs
Ripple & noise			1/2.5	%	Of nominal voltage/5V Standby. Measured with 20 MHz bandwidth limited oscilloscope 0-50°C.
Overshoot			5	%	Turn on & turn off
Overvoltage protection			120	%	Of nominal voltage, latching. Cycle AC to reset. No protection for 5V Standby
Overtemperature protection	Auto resetting thermal protection				
Overload protection			±3	% of max load	Set current limit point. Constant current characteristics. Max current limit is 108% ±3% of maximum rated current. <5A max
Temperature coefficient			0.03 of max load	%/°C	
Short circuit protection	Constant current characteristics. 5V/2A Standby: Foldback characteristic <5A max				
Remote sense	Compensates for 1% max of nominal voltage per lead, 2% of total nominal voltage drop. Not fitted on HPL5K0TS200				
5V standby supply	5V/2A standby supply, available whenever the mains supply is present				

## General

Characteristic	Minimum	Typical	Maximum	Units	Notes & conditions
Efficiency	92	93		%	Measured from 180 to 264VAC, 5V Standby at full load
Isolation: Input to output Input to ground Output to ground	4000 <sup>(1)</sup>			VDC	
	2500 <sup>(1)</sup>			VDC	
	500			VDC	
Switching frequency	40	45	50	kHz	Fixed frequency PFC
	40		250	kHz	Variable frequency main converter
Power density			15.38	W/in <sup>3</sup>	
Signals and controls	V Program, I Program, AC OK, DC OK, Fan Fail/Temperature Warning, Sync, PMBus, Inhibit, Current Share.				
MTBF		450		khrs	Telecordia 332, 25°C
Weight		12.5 (5.7)		lb (kg)	

1. Rating for complete assembly with HI-POT screw removed (see mechanical details for screw position). Maximum isolation test voltage is 2121VDC with screw installed.

## Environmental

Characteristic	Minimum	Typical	Maximum	Units	Notes & conditions
Operating temperature	-20		+70	°C	Derate linearly from 50°C to 50% rated power at 70°C
Storage temperature	-40		+85	°C	
Cooling	Force-cooled with intelligent fan speed control				
Humidity	5		95	%RH	Non-condensing
Operating altitude			5000	m	Medical
			5000		ITE
Transport altitude			10000	m	
Shock	±3 x 30g shocks in each plane, total 18 shocks. 30g = 11 ms (±0.5ms) half sine. Conforms to EN60068-2-27 & EN60068-2-47				
Vibration	Single axis 10-500Hz at 1.5g sweep and endurance at resonance in all 3 planes. Conforms to EN60068-2-6				
Acoustic noise	<70 db(A) Lw				

## Application notes

### Output voltage programming

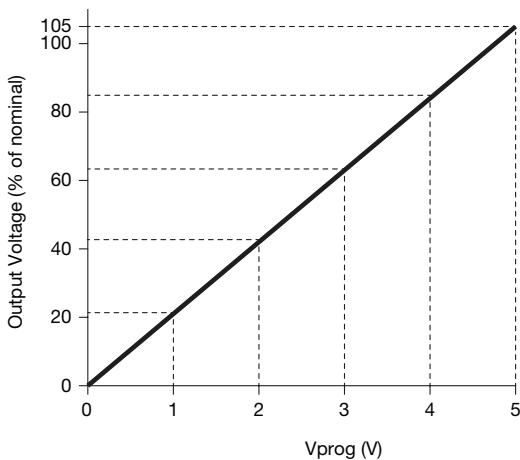

### Output current programming

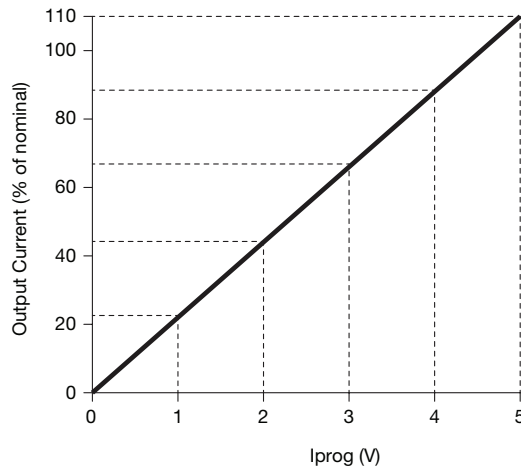

## Signals & controls

	Function
V program <sup>(1)(2)</sup>	0V to 5V signal will program Vout from 0-105%. VProg accuracy $\pm 1\%$ of nominal output voltage. When left open, supply will go into its default operating mode.
I program <sup>(1)(2)</sup>	0V to 5V signal will program the current limit from 0-110%. When this signal is left open, supply will go into its default operating mode. IProg accuracy $\pm 2\%$ of maximum rating.
AC OK	LOW = Input Voltage is within operating range, HIGH = Input Voltage is outside of operating range or there is a loss of phase. Uncommitted opto-transistor, 2ms warning time
DC OK	When the supply is used as a variable output supply, this signal is disabled. When the supply is programmed as a fixed output supply, LOW = Vout > 95% of Vnominal. This level is programmable by the user through the PMBus. Uncommitted opto-transistor
Fan fail/Temp warning	High = Fan FAIL and/or overtemperature, Low = Fan OK and temperature OK (3.3V Logic), unit switches off 10s after Fan Fail/Temp Warning alarm, auto recovery. XP GUI available for download, contact sales.
Sync.	Connect parallel units to synchronise output turn on.
PMBus, CANopen and RS485	The interface specification is detailed in a separate document "HPL5K0 Communication, Control and Status Specification". XP GUI available for download, contact sales. Vout monitor accuracy is $\pm 1\%$ of nominal voltage, Vout setting accuracy is $\pm 1\%$ of nominal voltage, Iout monitor accuracy is $\pm 2\%$ of full load, Iout setting accuracy is $\pm 2\%$ of full load.
Current share	Connecting pin 23 on one unit to pin 23 on a like voltage unit will force the current to be shared. Up to 5 units can be paralleled. Current share accuracy $\pm 3\%$ of full load of single unit.
Inhibit	Uncommitted opto diode. See signal connections.

(1) In analog mode, the default Vout and Iout settings are 0% when open circuit.

(2) To activate analog mode, PMBus\_EN (pin 24) must be pulled down to SGND. Default when open is digital programming.

## Safety approvals

Certification	Safety standard	Notes & conditions
CB report	IEC62368-1 Ed 2	Information technology
	IEC60601-1 Ed 3.1 Including Risk Management	Medical
UL	UL62368-1, CSA 22.2 No.62368-1	Information technology
	ANSI/AAMI ES60601-1:2005 & CSA C22.2, No.60601-1:08	Medical
EN	EN62368-1	Information technology
	EN60601-1/2006	Medical
CE	Meets all applicable directives	
UKCA	Meets all applicable legislation	
Equipment protection class	Class I	See safety agency conditions of acceptability for details

Isolation	Means of protection	Notes & conditions
Primary to secondary	2 x MOPP (Means of patient protection)	IEC60601-1 Ed 3.1
Primary to earth	1 x MOPP (Means of patient protection)	
Secondary to earth	N/A	

## EMC: emissions

Phenomenon	Standard	Test level	Notes & conditions
Conducted	EN55011/EN55032	Class B	
Radiated	EN55011/EN55032	Class A	
Harmonic currents	EN61000-3-2	Class A	

## EMC: immunity

Phenomenon	Standard	Test level	Criteria	Notes & conditions
ESD immunity	EN61000-4-2	4	A	±8kV contact / ±15kV air discharge
Radiated immunity	EN61000-4-3	3	A	
EFT/Burst	EN61000-4-4	3	A	
Surge	EN61000-4-5	Installation class 4	A	
Conducted	EN61000-4-6	3	A	
Magnetic field	EN61000-4-8	4	A	
Dips and interruptions	EN61000-4-11 (200 VAC)	Dip 100% (0 VAC), 8.4ms	A	
		Dip 100% (0 VAC), 16.7ms	A	
		Dip 60%, 200ms	A	
		Dip 30%, 500ms	A	
		Dip 20%, 5000ms	B	
		Int 100% (0 VAC), 5000ms	B	
	EN61000-4-11 (240 VAC)	Dip 100% (0 VAC), 10ms	A	
		Dip 100% (0 VAC), 20ms	A	
		Dip 60%, 200ms	A	
		Dip 30%, 500ms	A	
		Dip 20%, 5000ms	B	
		Int 100% (0 VAC), 5000ms	B	
	EN60601-1-2 (200 VAC)	Dip 100% (0 VAC), 10ms	A	
		Dip 100% (0 VAC), 20ms	A	
		Dip 60% (80/152 VAC), 100ms	A	
		Dip 30% 140/266 VAC	A	
		Int 100% (0 VAC), 5000ms	B	
	EN60601-1-2 (240 VAC)	Dip 100% (0 VAC), 10ms	A	
		Dip 100% (0 VAC), 20ms	A	
		Dip 60%, 100ms	A	
		Dip 30%, 500ms	A	
		Int 100% (0 VAC), 5000ms	B	
	SEMI F47-0706		208VAC nominal	A

## Signals connection

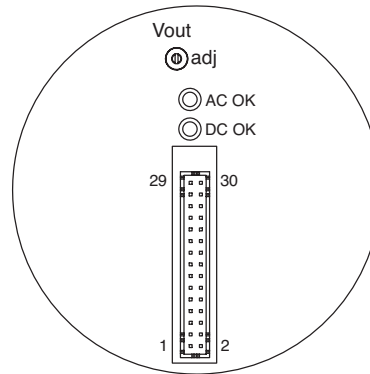

View A

J1 signal connector connections		
Pin	Function	Description
1	DCOK	Low means Vout is within range (Opto Isolated; Open Collector)
2	DCOK return	Return for DCOK (Opto Isolated)
3	Remote inhibit	High to Inhibit - uncommitted opto diode
4	Remote inhibit return	Return for Inhibit - uncommitted opto diode
5	A0	I <sup>2</sup> C Device Address Bit (10k $\Omega$ pull up to 3.3V)
6	A1	I <sup>2</sup> C Device Address Bit (10k $\Omega$ pull up to 3.3V)
7	A2	I <sup>2</sup> C Device Address Bit (10k $\Omega$ pull up to 3.3V)
8	CANH	CAN Bus Communication using CANopen protocol
9	RS485_Y	RS485 Differential Serial Bus Communication
10	CANL	CAN Bus Communication using CANopen protocol
11	RS485_Z	RS485 Differential Serial Bus Communication
12	SGND	Signal Return
13	RS485_A	RS485 Differential Serial Bus Communication
14	I <sup>2</sup> C SDA	I <sup>2</sup> C (10k $\Omega$ pull up to 3.3V)
15	RS485_B	RS485 Differential Serial Bus Communication
16	I <sup>2</sup> C SCL	I <sup>2</sup> C Bus Clock (10k $\Omega$ pull up to 3.3V)
17	FAN_FAIL/TEMP WARNING	Fan Failure/Temp Warning Reporting (High means fan fails and/or overtemperature rating; 10k $\Omega$ pull up to 3.3V)
18	SYNC	Connect parallel units to synchronise output turn on
19	VPROG	0 - 5V to set Vout from 0 to 105% <sup>(1)</sup> (50.8 k $\Omega$ discharge resistor to SGND <sup>(2)</sup> )
20	RS+	Positive Remote Sense (HPL5K0TS048, HPL5K0TS060 and HPL5K0TS100 only)
21	RS-	Negative Remote Sense (HPL5K0TS048, HPL5K0TS060 and HPL5K0TS100 only)
22	I <sup>2</sup> C IPROG	0 - 5V to set Current Limit from 0 - 110% of rated current <sup>(1)</sup> (50.8 k $\Omega$ discharge resistor to SGND <sup>(2)</sup> )
23	ISHARE	0 - 2.6V for current sharing of units in parallel
24	PMBUS_EN	Selecting Digital (open) or Analog (low) mode for VPROG & IPROG (10k $\Omega$ pull up to 3.3V)
25	ACOK	Low means AC is within range operating range (Opto Isolated; Open Collector)
26	ACOK Return	Return for ACOK (Opto isolated)
27	5VSBY	5V/2A Standby
28	5VSBY	5V/2A Standby
29	5VSBY_RTN	5V/2A Standby Return
30	5VSBY_RTN	5V/2A Standby Return

### Notes:

1. In analog mode, the default Vout & Iout settings are 0% when Vprog & Iprog are open circuit.
2. To activate analog mode, PMBUS\_EN must be pulled down to 5VSBY-RTN. Default if left open is digital programming.

## Signals & controls

### DC OK

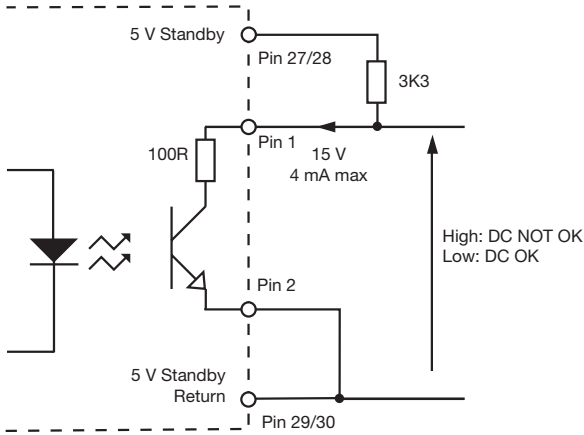

### AC OK

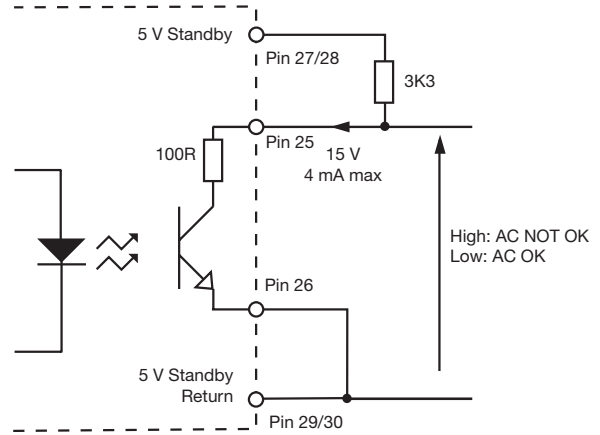

### Fan fail/Temperature warning

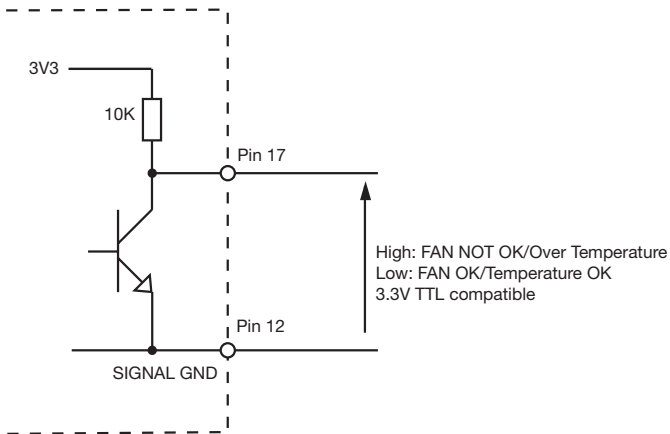

### Inhibit

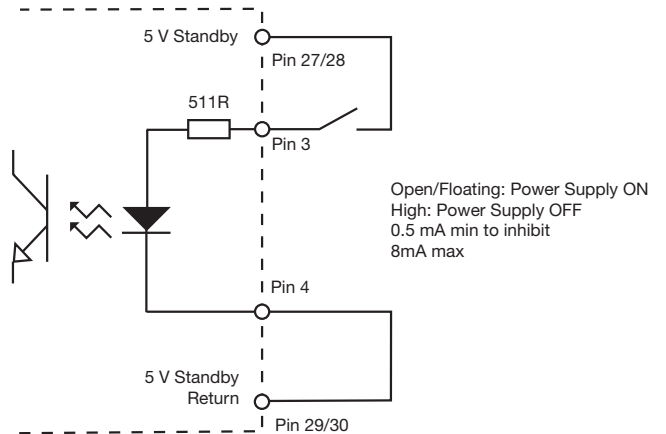

### Current share

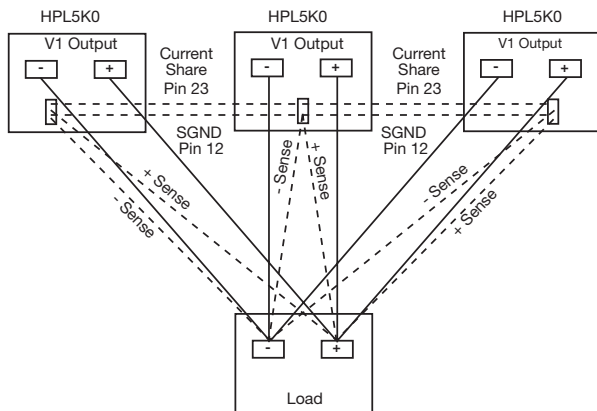

Up to 5 x HPL5K0 units

To synchronise output turn on from application of AC input, connect SYNC (pin 18) of parallel units together.

## LED signals

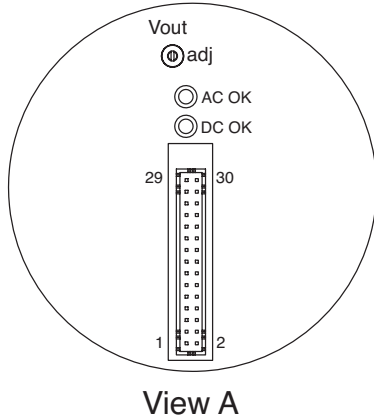

Conditions	LED state		Signals			
	AC OK	DC OK	AC OK	DC OK	FAN_FAIL/TEMP	Remote inhibit
AC input OK	ON	ON <sup>(3)</sup>	LOW	LOW	LOW	LOW
AC not present or too low	OFF	OFF	HIGH	HIGH	LOW	X <sup>(2)</sup>
AC present but out of range or PFC failure or no primary to secondary communication	Blink (0.2s ON, 0.2s OFF)	OFF	HIGH	HIGH	LOW	X <sup>(2)</sup>
Output over voltage	ON	OFF	LOW	HIGH	LOW	LOW
Current limit (Constant current response)	ON	Blink (0.2s ON, 0.2s OFF)	LOW	LOW or HIGH <sup>(3)</sup>	LOW	LOW
Fan failure/Thermal shutdown	ON	OFF	LOW	HIGH	HIGH <sup>(1)</sup>	LOW
Remote OFF	ON	Blink (1.0s ON, 1.0s OFF)	LOW	HIGH	LOW	HIGH
PMBus operation OFF	ON	Blink (1.0s ON, 1.0s OFF)	LOW	HIGH	LOW	LOW

### Notes:

- In case of fan failure, and/or Overtemperature, FAN\_FAIL/Temp Warning signal will be set 10s before output shutdown.
- Don't care / not applicable.
- DC\_OK LED is ON if Output Voltage  $\geq$  VOUT\_UV\_FAULT\_LIMIT, if Output Voltage  $<$  VOUT\_UV\_FAULT\_LIMIT, the DC\_OK LED will be OFF

## Mechanical details

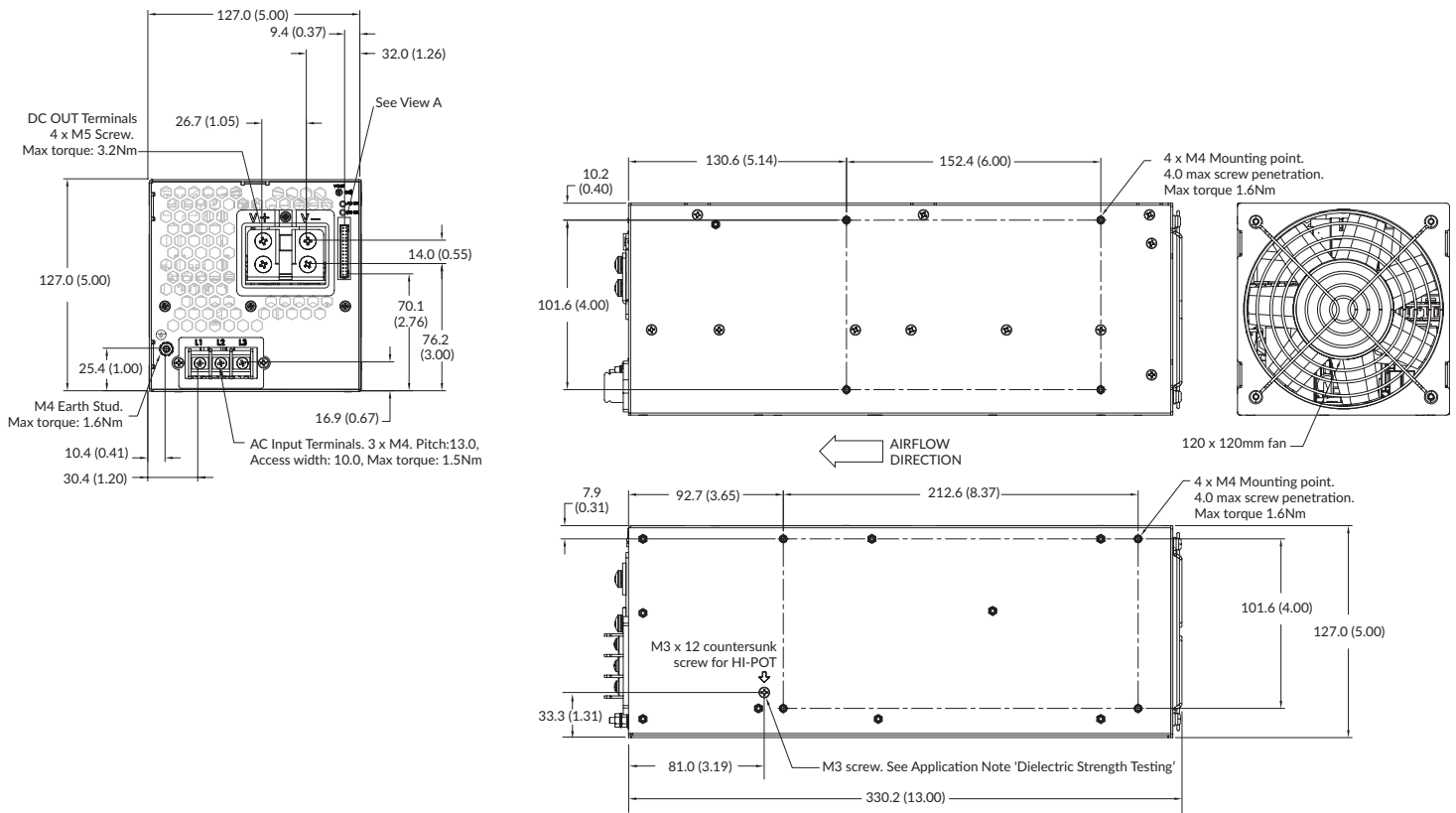

### Notes:

- All dimensions are in mm (inches).
- Weight 5.7kg (12.5lb)
- Signal Connector: P/N JST S30B-PHDS5 (LF) (SN) or equivalent  
Mates with P/N JST PHDR-30VS or equivalent  
Contact: SPHD-002T-P0.5

Specifications subject to change without notice.