

12W

AC-DC
power supplies

The VER12 series of 12W class II wall plug adaptors comply with energy efficiency VI standards, have high active mode efficiency, low no load power consumption and are limited power source (LPS) approved.

Supplied complete with interchangeable US, UK, EU, CN & AU mains plugs, the DC lead has a 5.5mm x 2.1mm centre positive barrel jack plug connector, these adaptors suit a wide variety of cost sensitive applications while maintaining industry leading performance.



Features

- ▶ Output voltages from 5V to 12VDC
- ▶ Energy efficiency level VI
- ▶ European CoC tier 2
- ▶ Interchangeable AC mains connectors included
- ▶ Universal input
- ▶ Class II construction
- ▶ Limited power source (LPS) approved
- ▶ 1 year warranty

Applications

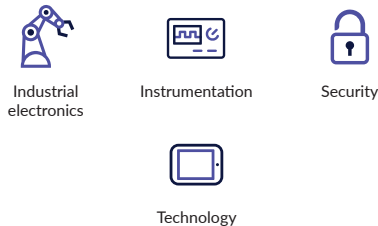

Dimensions

Body only:
76.5 x 41.0 x 37.6mm (3.01" x 1.61" x 1.48")

Models & ratings

Model number	Output voltage	Output current	Total regulation ⁽²⁾	Output connector	Output power
VER12US050-JA	5.0VDC	2100mA	5%	5.5 x 2.1 x 12mm DC Jack	12W
VER12US090-JA	9.0VDC	1280mA		5.5 x 2.1 x 12mm DC Jack	
VER12US120-JA	12.0VDC	1000mA		5.5 x 2.1 x 12mm DC Jack	

Notes:
1. Other output voltages available, contact sales for details. 2. Total regulation includes initial set accuracy, line and load regulation.

Input

Characteristic	Minimum	Typical	Maximum	Units	Notes & conditions
Input voltage	90		264	VAC	
Input frequency	47		63	Hz	
Power factor	EN61000-3-2 class A				
Input current			0.3	A	100VAC
Inrush current			60	A	240VAC cold start, +25°C
No load input power			0.1	W	
Input protection	Internal T1.0A/250VAC fuse				

Output

Characteristic	Minimum	Typical	Maximum	Units	Notes & conditions
Output voltage	5		12	VDC	See models & ratings
Minimum load	No minimum load required				
Start up delay			4	s	
Start up rise time		30		ms	
Hold up time	10			ms	Full load and 100VAC
Total regulation			5	%	See models & ratings
Transient response			4	% deviation	Recovery within <1% within 500µs for a 60% step load change at 0.15A/µs
Ripple & noise			150	mV pk-pk	Measured with 20MHz bandwidth and 47µF electrolytic in parallel with 0.1µF ceramic capacitor
Temperature coefficient			0.05	%/°C	
Short circuit protection	Continuous, trip and restart (hiccup mode) with auto recovery				

General

Characteristic	Minimum	Typical	Maximum	Units	Notes & conditions
Efficiency		79/83		%	5V/9V, 12V typical average of efficiencies measured at 25%, 50%, 75% and 100% load and 115 VAC input
Energy efficiency	Level VI				
Isolation		3000		VAC	Input to output
Switching frequency	24		70	kHz	Variable
Mean time between failure	100			khrs	MIL-HDBK-217F, 25°C GB
Weight		80 (0.28)		g (lb)	Body only

Environmental

Characteristic	Minimum	Typical	Maximum	Units	Notes & Conditions
Operating Temperature	0		+60	°C	Derate from 100% load at +40°C to 50% load at +60°C
Storage Temperature	-40		+85	°C	
Cooling	Natural convection				
Operating Humidity	5		95	%	RH, non-condensing
Shock	1m drop onto concrete on each of 6 axes				
Vibration	10		300	Hz	2g, 15 mins/sweep, 30 mins for each of 3 axes

EMC: Emissions

Phenomenon	Standard	Test level	Notes & conditions
Conducted	EN55032	Level B	
Radiated	EN55032	Level B	
Harmonic currents	EN61000-3-2	Class A	
Voltage flicker	EN61000-3-3		

EMC: Immunity

Phenomenon	Standard	Test level	Criteria	Notes & conditions
ESD immunity	EN61000-4-2	2,3	A	±4kV contact, ±8kV air
Radiated immunity	EN61000-4-3	3V/m	A	
EFT/burst	EN61000-4-4	Level 2	A	
Surge	EN61000-4-5	Level 2	A	
Conducted	EN61000-4-6	3V	A	
Magnetic field	EN61000-4-8	1A/m	A	
Dips and interruptions	EN55024 100% 10ms, 30% 500ms, 100% 5000ms, Perf Criteria A, A, B			

Safety approvals

Certification	Standard	Notes & conditions
UL	UL/cUL62368-1	Approved as limited power source (LPS)
EN	EN60950-1, EN62368-1	
CB	IEC60950-1, IEC62368-1	
CCC	China Compulsory Certification, GB4943	
AU/NZ	AU/NZ 60950.1	
CE	Meets all applicable directives	
UKCA	Meets all applicable legislation	

Mechanical details

VER12US

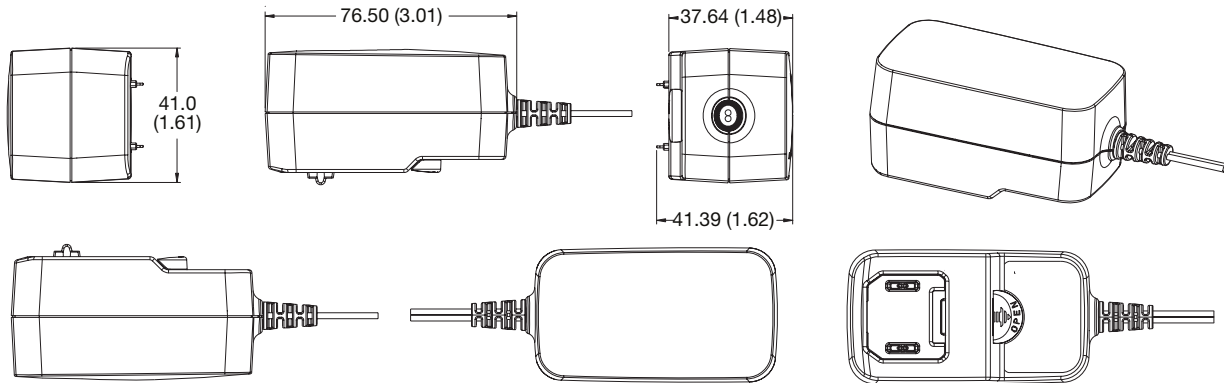

AC input plugs

UK plug

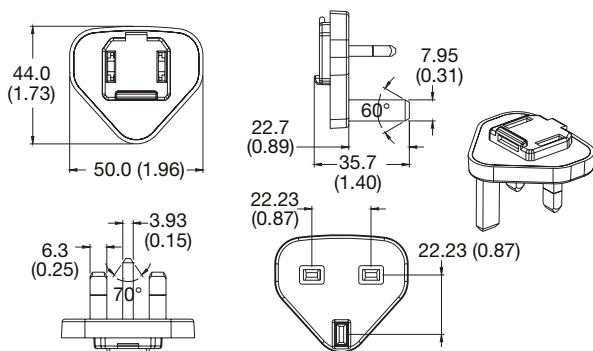

US plug

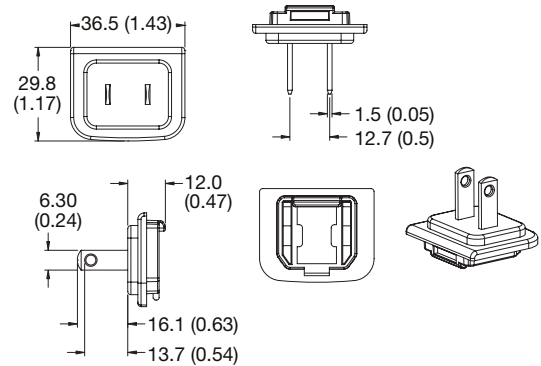

AU plug

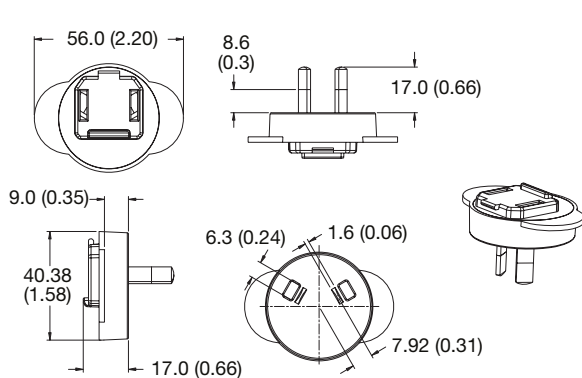

EU plug

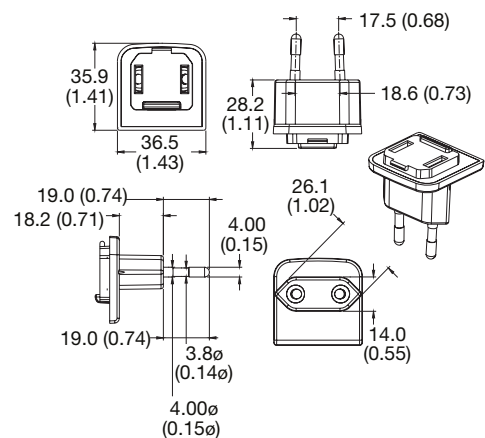

Notes:

1. Dimensions in mm (inches).

Mechanical details

CN plug

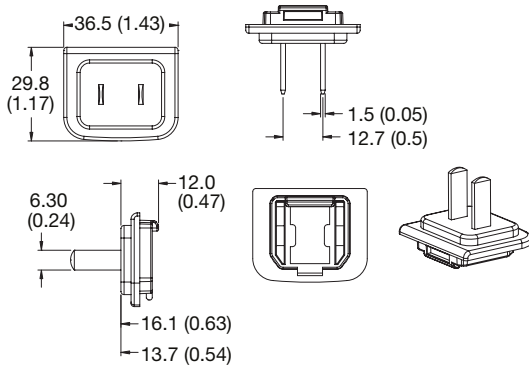

Output lead and connection

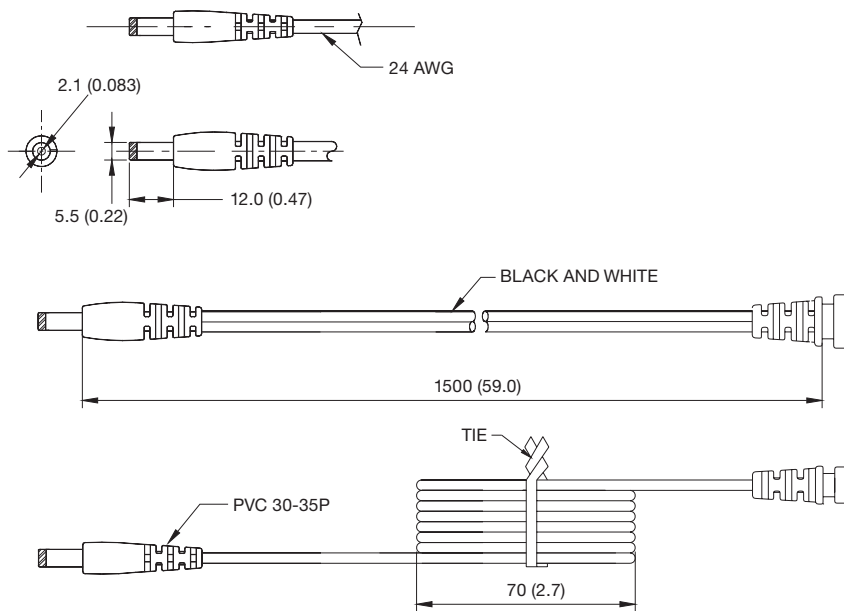

Wire type: VW-1 80°C 300V L=1500mm 2468 20AWG for 5 V output, 22AWG for 9V output, 24AWG for 12 V output, 2C Black and White. Black - Negative, White - Positive

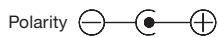

Notes:

1. Dimensions in mm (inches).

Specifications subject to change without notice.