

DSF226 Series



- Up to 200 W Output Power
- Active Surge Protection
- MIL-STD 461 & DEF-STAN 59-411
- MIL-STD 1275
- DEF-STAN 61-5 Part 6 Issue 6
- MIL-STD 810
- 3 Year Warranty

Specification

Input

- | | |
|----------------------------------|--------------------------------------------------------------------------------------------------------------------------------------------------------------------------------------------------------------------------------------------------------------------------|
| Input Voltage Range | • 15 - 33 VDC |
| Input Transient | • ± 250 V for 70 μ s 15 mJ,
100 V for 50 ms 0.5 Ω
per MIL-STD-1275A/B/C/D
± 600 V for 10 μ s per MIL-STD-704A,
± 200 V for 100 ns, pulse train,
174 V+ V_{in} for 350 ms
per DEF-STAN 61-5 part 6 issue 6
10V for 1 s. |
| Input Reverse Voltage Protection | • Continuous |
| Fuse Protection | • External T25 A fuse is recommended |

Output

- | | |
|--------------------------|------------------------------------------------------------------------------------------------------------------------------------------------------------------------------------------------------------------------------------------------------------------------------------------------------------------------------------------------------------------------------------------------------------------------------------------------------------------------------------------------------------------------------------------------------------------------------------------------------------------------------------------------------------------------------------------------|
| Output Voltage | • Tracks input voltage & clamps <36 VDC |
| Output Power | • 200 W max |
| Thermal Warning (TW) | • The TW output is an open collector transistor rated at 100 VDC, with a maximum sink current of 10 mA, referenced to $-V_{in}/-V_{out}$. The signal output is low when the maximum base plate temperature is exceeded. This signal indicates an over temperature condition so that action can be taken by the end application such as shutting down non critical loads or individual downstream DC/DC converters. If connected to the DIS pin of the DSF226 this will disable the filter output and perform as a thermal shut down for the system. The TW output will automatically return to a high signal level once the filter base plate has cooled to a temperature of less than 100°C. |
| Maximum Output Capacitor | • 10,000 μ F recommended |

General

- | | |
|------------------------|-----------------------------------------------------------|
| Efficiency | • 97% typical |
| Isolation Voltage | • 500 VDC Input & Output to Case |
| Series Resistance | • <0.1 Ω |
| Disabled Input Current | • <25 mA |
| Disable (DIS) | • On = Open circuit
Off = Logic low or short circuit |
| No Load Current | • <35 mA |
| Package Style | • Photo-etched nickel-silver case and aluminium baseplate |
| MTBF | • >2000 kHrs to MIL-HDBK-217F at 40 °C, GB |

Environmental

- | | |
|-----------------------|--------------------------------------------------------------------------------------------------------------------------------------------|
| Operating Temperature | • -46 °C to +100 °C baseplate |
| Storage Temperature | • -55 °C to +100 °C |
| Salt Atmosphere | • MIL-STD-810G method 509.4 |
| Humidity | • MIL-STD-810G 507.4 |
| Altitude | • MIL-STD-810G 500.4 |
| Shock | • MIL-STD-810G 516.5 function test for ground equipment 40 g in 3 axes |
| Vibration | • MIL-STD-810G method 514.5C-17. Minimum integrity test for military equipment (1 Hr/axis, 3 axes). Vibration 5-33 Hz, 0.5 mm displacement |

EMC & Safety

- | | |
|------------------|-----------------------------------------------------------------------------------------------------------------|
| Immunity | • MIL-STD-1275A-D, MIL-STD-461E/F/G (CS101, CS114, CS115 & CS116) MIL-STD-704A, DEF-STAN 61-5 part 6 issue 6 |
| Emissions | • MIL-STD 461E/F/G CE101, CE102 & DEF STAN 59-411 DCE01/DCE02 with external components. (See application notes) |
| Safety Approvals | • CE & UKCA meets all applicable directives & legislation. |

Models & Ratings

Output Power	Input Voltage	Output Voltage	Typical Efficiency	Model Number
200 W	15-33 VDC	<36 VDC	97%	DSF226

Mechanical Details

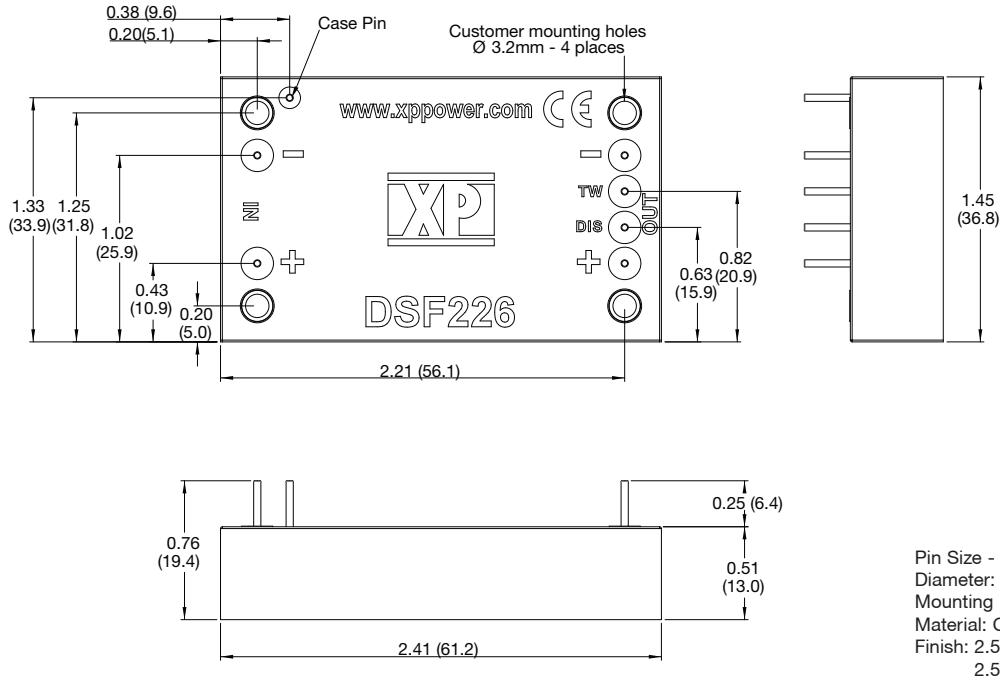

Notes

- All dimensions in inches (mm).
- Weights: 0.165 lbs (75 g)
- Tolerance ±0.012 (±0.3)

Application Notes

Typical Schematic for DEF-STAN 59-411 Compliance

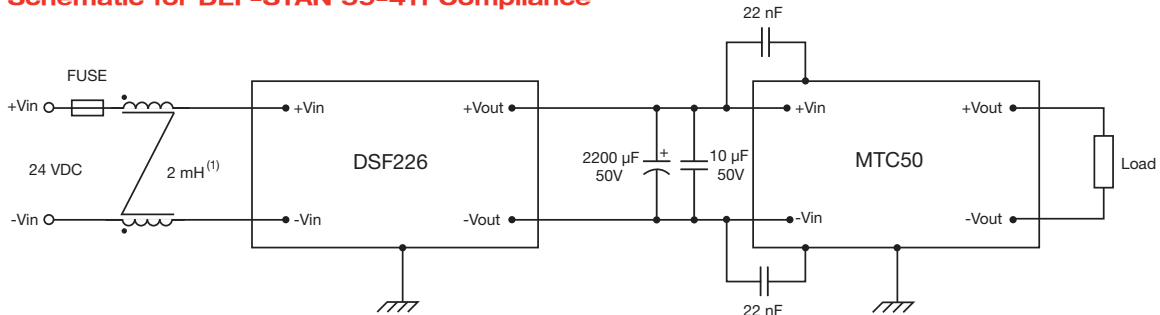

(1) Common mode choke part number W409 core from VAC and 2 x 6 turns, 1.5 mm wire.

Typical Schematic for MIL-STD-461 Compliance

