

# GFR1K5 Handbook



GFR1K5

GFR1K5 Rack - Provides up to 6 kW in a 19" rack  
(See rack section)

- 1U Blind-Mate Hotswap Redundant
- All models share the same compact size
- 56V POE Compatible Model
- Load dependant variable speed fans for audible noise reduction
- High Power Density – 18 W/in<sup>3</sup>
- Up to 6 kW in 1U Rack Available
- Customizable Faceplate & Field Replaceable Fans
- -20 °C to +70 °C Operation
- 5V / 1A Standby Rail
- AC OK, DC OK, Inhibit, Enable, Pwr ID & Current Share Signals
- I<sup>2</sup>C Interface

The GFR1K5 is a 1U 1500 Watt AC - DC front end with market leading power density that is designed for use in communications applications such as networking, broadcast, data storage, power over ethernet, power amplifiers and other applications that require bulk power and/or need redundant or hotswap power supplies. The GFR1K5 delivers 1200 Watts at Low Line and 1500 Watts at High Line with four output models 12 V, 24 V, 48 V and 56 V. The 56V model meets the requirements of the IEEE 802.3.AF for power over ethernet. All four models have the same form factor making it easy to design a system that needs to combine output voltages. An innovative electrical keying system protects the GFR if inserted in the wrong slot.

The GFR1K5 has an extensive signals and control set including inhibit, enable, voltage trim, parallel, AC OK, failure detect and I<sup>2</sup>C Interface. A detailed I<sup>2</sup>C Interface applications note is available on request. Variable speed fan controller reduces fan noise by 30% in a typical hotswap application. Up to 8 GFR units can be paralleled at one time. A standard 1U 19" Rack is also available which has space for 4 GFR's (6kW) along with I/O connections for power, signals & control. The standard rack is easily customised to suit customer specific requirements.

## Models and Ratings

Table 1

Output Power	Output Voltage V1	Voltage Adj V1	Max Output Current V1		Standby Supply V2	Model Number
			90-264 VAC	> 180 VAC		
1200 W	12.0 VDC	11-14 V	100 A	100 A	5 V/1 A	GFR1K5PS12
1500 W	24.0 VDC	22-28 V	50 A	63 A	5 V/1 A	GFR1K5PS24
1500 W	48.0 VDC	45-52 V	25 A	31 A	5 V/1 A	GFR1K5PS48
1500 W	56.0 VDC	54-59 V	22 A	27 A	5 V/1 A	GFR1K5PS56

## Input Characteristics

Table 2

Characteristic	Minimum	Typical	Maximum	Units	Notes & Conditions
Input Voltage - Operating	85	115/230	264	VAC	Derate output power < 90 VAC. See fig. 1.
Input Frequency	47	50/60	63	Hz	
Power Factor		>0.9			EN61000-3-2 class A compliant
Input Current - No Load		0.6		A	
Input Current - Full Load		13/6.5		A	115/230 VAC
Inrush Current			35	A	230 VAC cold start, 25 $\mu$ C
Earth Leakage Current		0.45/0.9	1.5	mA	115/230 VAC/50 Hz (Typ.), 264 VAC/60 Hz (Max.)
Input Protection	T20 A/250 V internal fuse in both line and neutral				

## Input Derating Curve

Figure 1

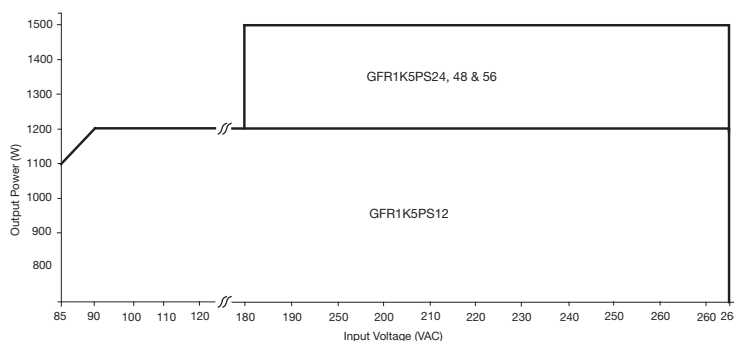

## Output Characteristics

Table 3

Characteristic	Minimum	Typical	Maximum	Units	Notes & Conditions
Output Voltage - V1	12		56	VDC	See Models and Ratings table
Initial Set Accuracy			$\pm 1^{(V1)}$ , $\pm 5^{(V2)}$	%	50% load, 115/230 VAC
Output Voltage Adjustment				%	V1 only. See model table above & mech. details.
Minimum Load	0			A	
Start Up Delay		1		s	230 VAC full load, see fig.2
Drift			$\pm 0.2$	%	After 20 min warm up
Line Regulation			$\pm 0.5$	%	90-264 VAC
Load Regulation			$\pm 1^{(V1)}$ , $\pm 5^{(V2)}$	%	0-100% load.
Transient Response - V1			4	%	Recovery within 1% in less than 500 $\mu$ s for a 50-75% and 75-50% load step
Over/Undershoot - V1		0.5		%	See fig.3
Ripple & Noise			2	% pk-pk	V1: 12 V models, 20 MHz bandwidth
			1		V1: 24-56 V models, 20 MHz bandwidth, see fig.4
			3		V2: 5 V standby, 20 MHz bandwidth
Overvoltage Protection	115		140	%	Vnom DC. Output 1 only, recycle input to reset
Overload Protection	110		140	% I nom	Output 1 only, auto reset. See fig 5.
Short Circuit Protection					Continuous, trip & restart (hiccup mode) all outputs
Temperature Coefficient			0.02	%/ $^{\circ}$ C	
Overtemperature Protection				$^{\circ}$ C	Protects unit from overtemperature. Auto reset.

### Start Up Delay From AC Turn On

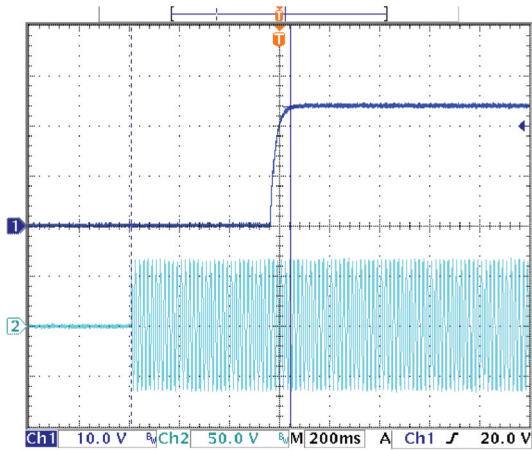

Figure 2 - V1 Start up examples from AC turn on (650ms)

### Overshoot

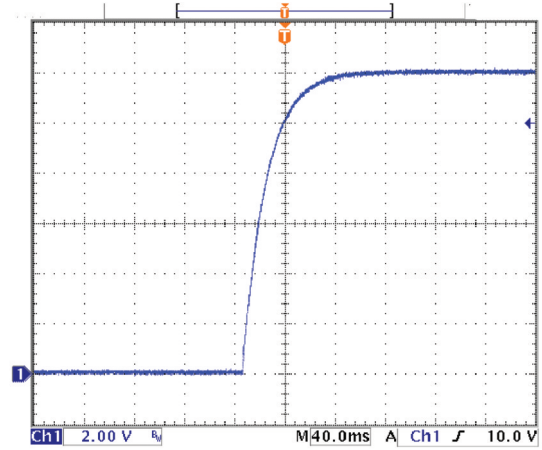

Figure 3 - V1 Typical no overshoot at start up.

### Output Ripple and Noise

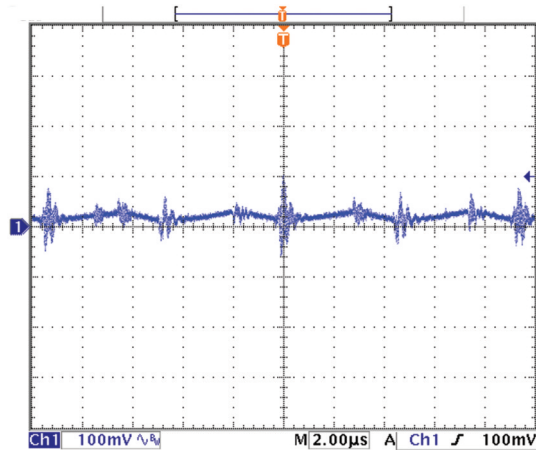

Figure 4 - V1 GFR1K5PS24 (Full load) 160mV pk-pk ripple and noise 20 MHz bandwidth

### Output Overload Characteristic

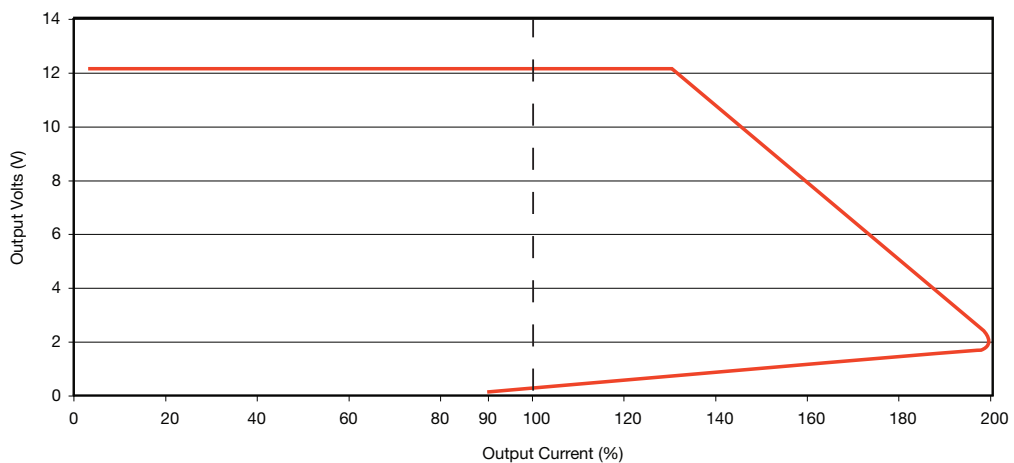

Figure 5  
Typical V1 Overload  
Characteristic  
(GFR1K5PS12 shown)

## General Specifications

Table 4

Characteristic	Minimum	Typical	Maximum	Units	Notes & Conditions
Efficiency		90		%	
Isolation: Input to Output Input to Ground Output to Ground <sup>(1)</sup>	3000/4000			VAC	12-24 V models / 48-56 V models
	1500			VAC	
	500 / 1500			VDC / VAC	12-24 V models / 48-56 V models
Switching Frequency		70/130		kHz	PFC converter / Main converter
Power Density			18	W/in <sup>3</sup>	
Mean Time Between Failure		470		kHrs	TELECORDIA SR-332, 25 °C
Weight			5.2 (2.35)	lb (kg)	

1. See page 8 for information of how to achieve the required signal isolation for POE compatibility (See fig. 19).

## Signals & Control

Table 5

Characteristic	Notes & Conditions
<b>Signals &amp; Control</b>	
Remote Sense	Compensates for 0.5 V total voltage drop
AC OK	AC OK is an opto isolated transistor, referenced to logic ground, providing a minimum of 3 ms warning of loss of output regulation. The signal is fully isolated and the collector and emitter must be connected externally. The transistor is normally on when AC is healthy. See fig. 6 & 16.
DC OK	DC OK is an opto isolated transistor, referenced to logic ground, providing warning of loss of output. The signal is fully isolated and the collector and emitter must be connected externally. The transistor is normally on when output DC is healthy. See fig. 7 & 16.
Inhibit	Floating isolated optocoupler diode referenced to logic ground powered diode inhibits the supply. See fig. 8 & 18.
Enable	Enable pin should be pulled low with reference to V1 ground to switch the output on. Enable pin is shorter and mates last when the unit is plugged into a mating connector. The Enable pin location differs between 12/24V & 48/56V models. See fig. 13.
Fault	Fault is an opto isolated transistor, referenced to logic ground, providing warning of power fail, DC fail or fan fault. The signal is fully isolated and the collector and emitter must be connected externally. The transistor is normally on when there is a fault. See fig. 9.
Pwr ID	The power ID pin B2 can be used to detect the presence of the unit when fitted in a rack. See fig. 14.
Current Share	Connecting pins A1 and C1 of like voltage units (8 maximum) will force the current to share between the outputs. Units share current within 10% of each other at full load. See fig. 12 & 15.
V Program	The voltage program function allows $\pm 10\%$ remote adjustment of V1 via 0-5V signal. See fig. 10.
Current Monitor	Enables the monitoring of the supplied current from V1 output. See fig. 11.
I <sup>2</sup> C	The I <sup>2</sup> C PMBus compatible interface can be used for monitoring the unit output voltage, current, internal temperature and run time. It can also be utilized to turn the unit on and off, detect faults along with identification of the unit model number and serial number. A separate application note is available detailing the use of this interface, contact sales for further information. See table 5.
5V Standby (V2)	5 V/1 A supply, always present when AC supplied

## Signals & Control

### AC OK

Maximum sink current 2 mA, maximum voltage 20 V.

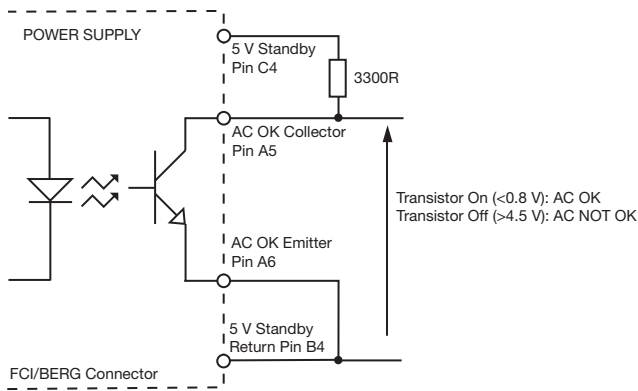

Figure 6

### DC OK

Maximum sink current 2 mA, maximum voltage 20 V.

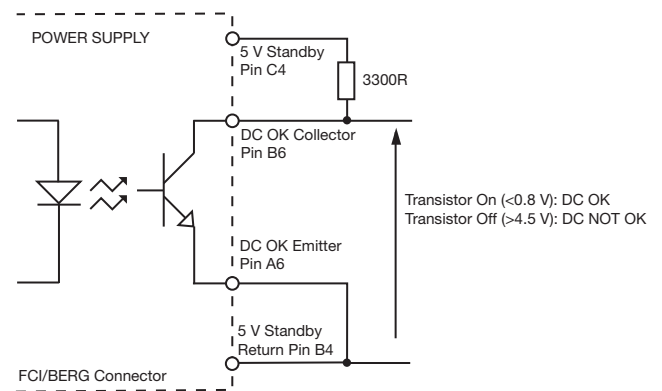

Figure 7

### Inhibit

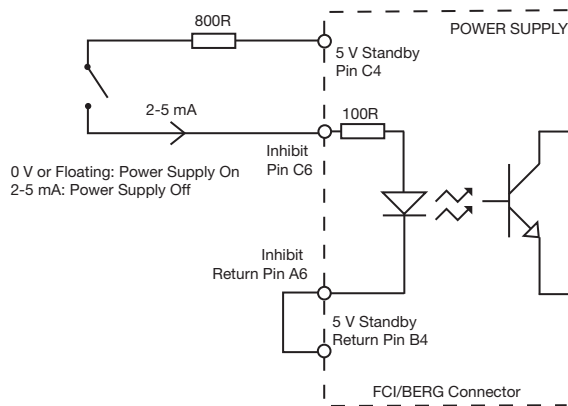

Figure 8

### Fault

Maximum sink current 2 mA, maximum voltage 20 V.

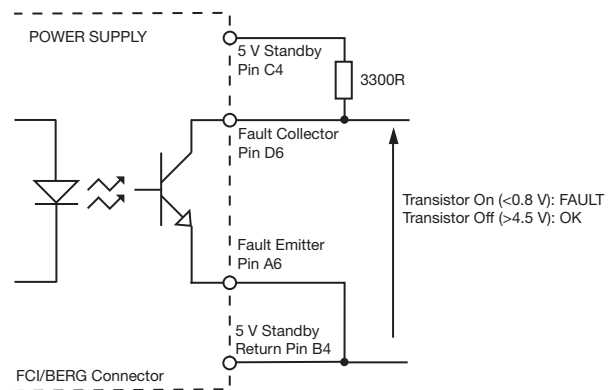

Figure 9

### V Program

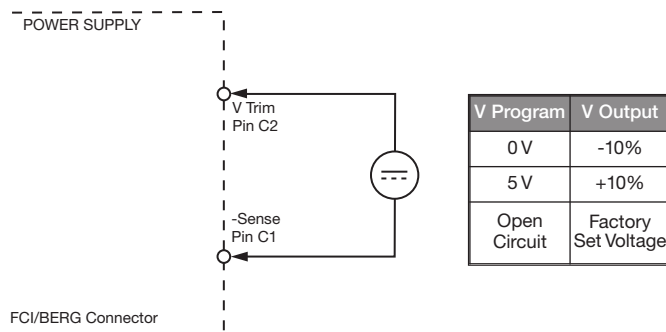

Figure 10

### Current Monitor

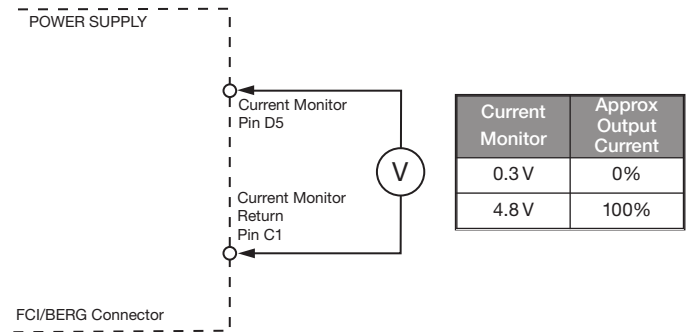
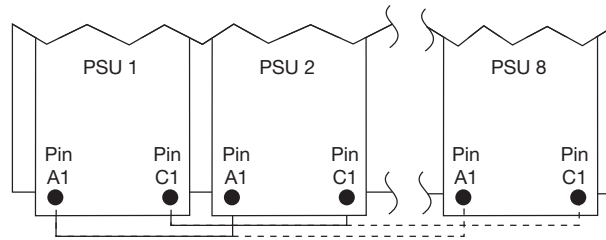

Figure 11

## Signals & Control

### Current Share

Figure 12



### Enable

Figure 13

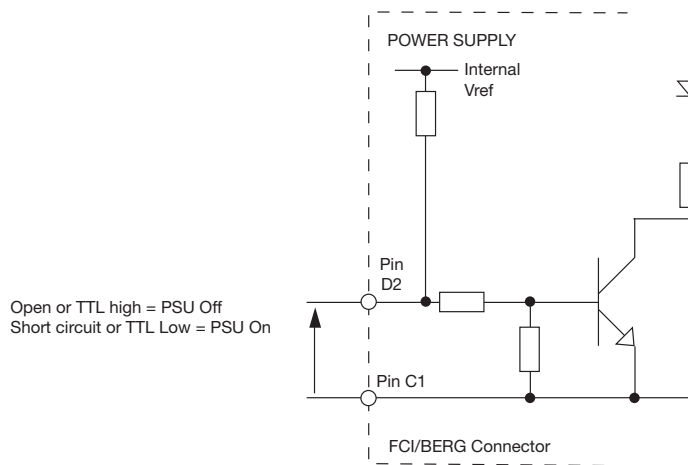

### Power ID

Figure 14

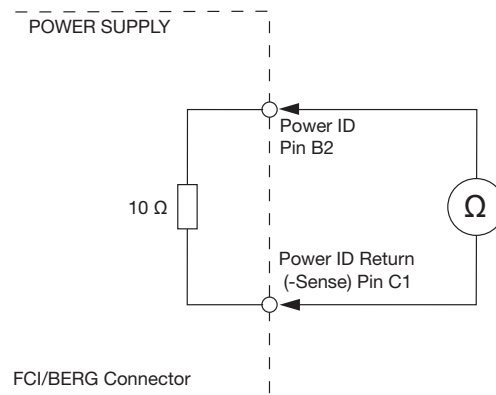

## Signals - Parallel Load & Current Share Connection Example

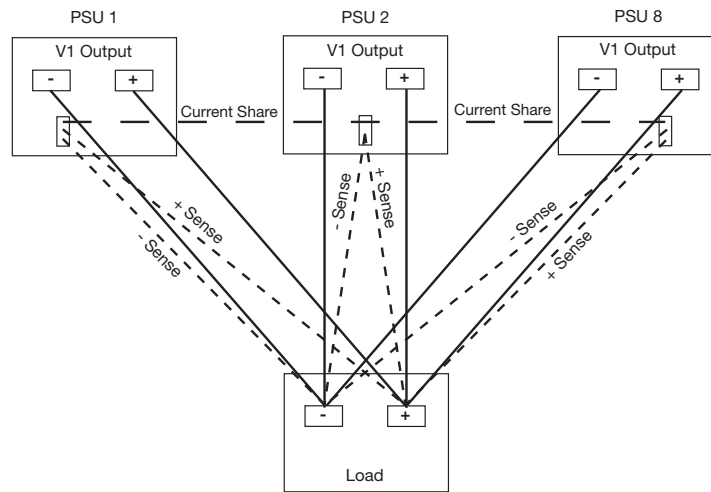

Figure 15

## Parallel AC OK Connection (DC OK follows same format)

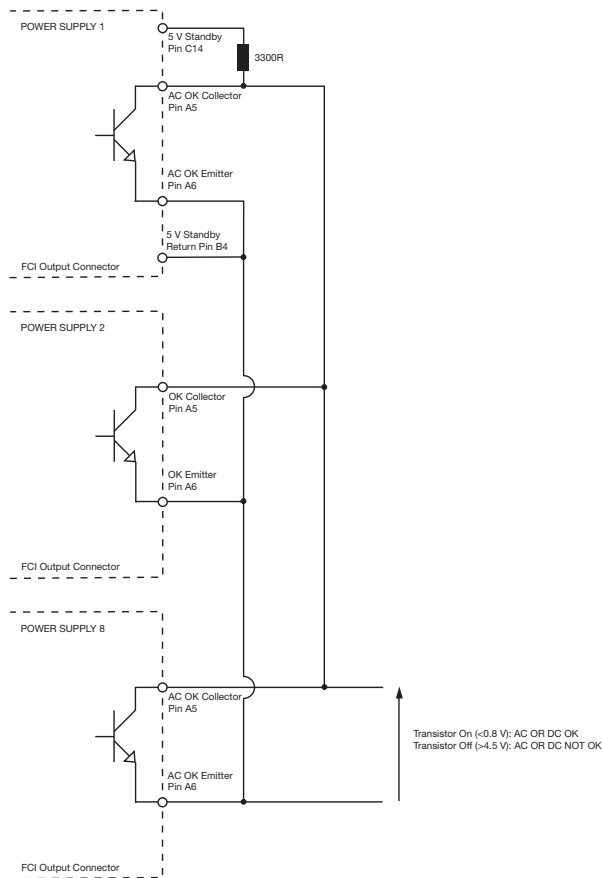

Figure 16

## Parallel Remote Inhibit Connection

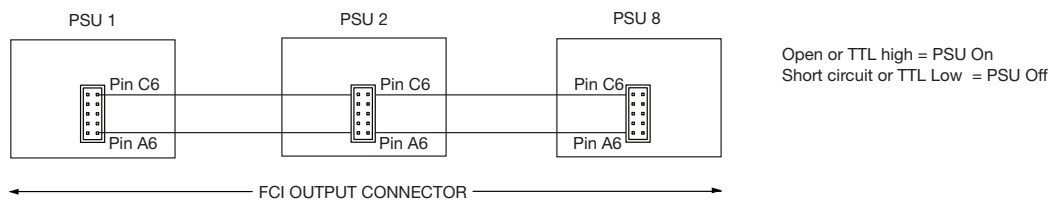
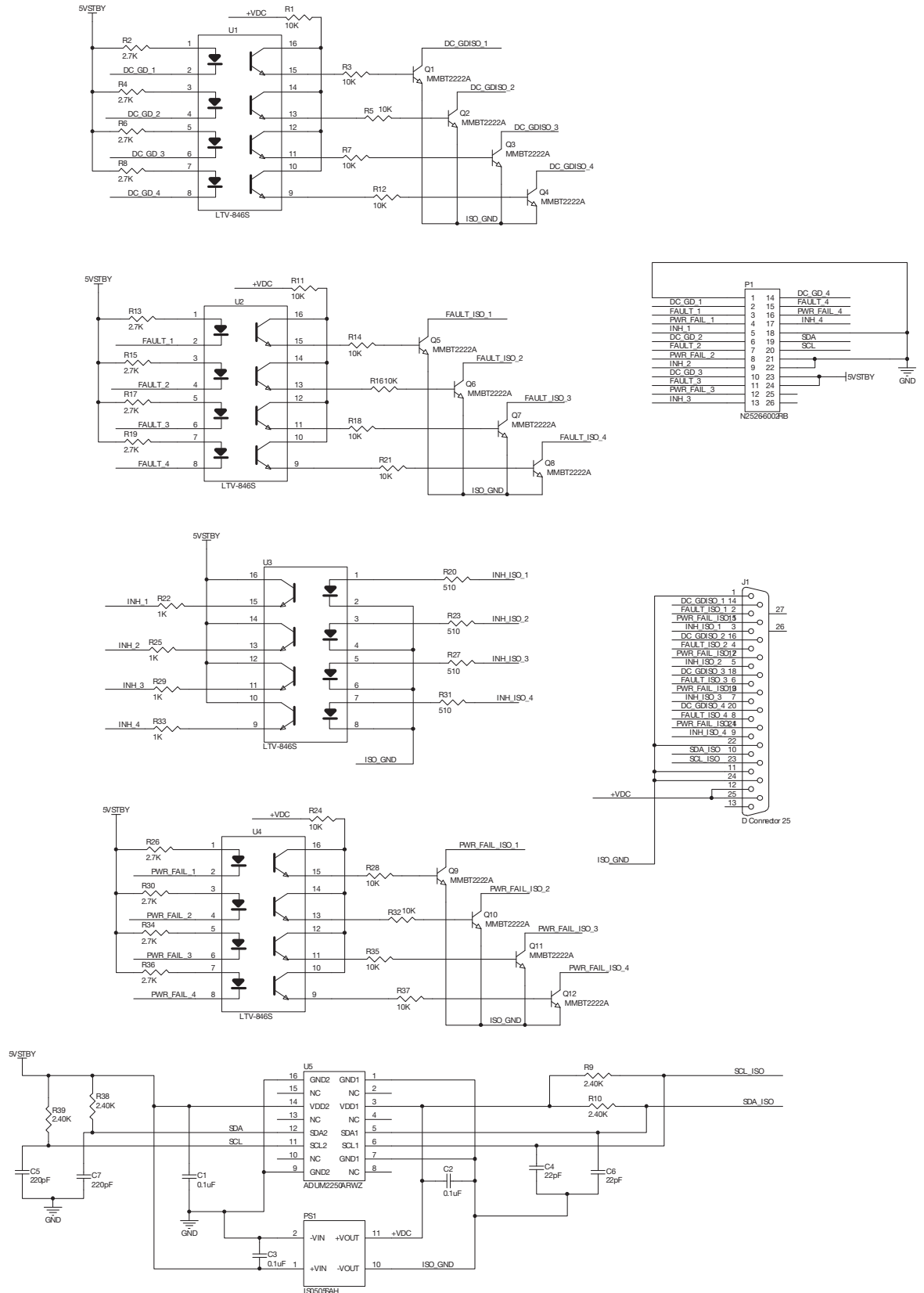

Figure 17

## POE Compatibility

The signals within the GFR1K5 require additional isolation compliance to achieve POE. A typical application circuit is shown below for reference. Contact sales for further detailed information.

Figure 18



## Environmental

Table 6

Characteristic	Minimum	Typical	Maximum	Units	Notes & Conditions
Operating Temperature	-20		+70	°C	Derate linearly from +50 °C at 2.5%/°C to 50% at 70 °C. See fig. 20.
Warm up time		20		Minutes	
Storage Temperature	-40		+85	°C	
Cooling				CFM	2 x integral variable speed fans load dependant
Humidity	5		95	%RH	Non-condensing
Operating Altitude			3000	m	
Shock					3 x 30 g/11 ms shocks in both +ve & -ve directions along the 3 orthogonal axis, total 18 shocks.
Vibration					Single axis 10-500 Hz at 2 g x 10 sweeps

## Temperature Derating Curve

Figure 19

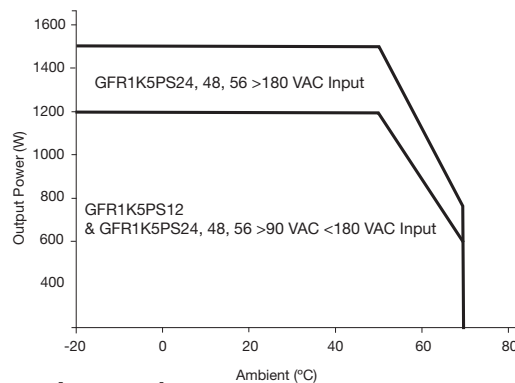

## Electromagnetic Compatibility - Immunity

Table 7

Phenomenon	Standard	Test Level	Criteria	Notes & Conditions
Low Voltage PSU EMC	EN61204-3	High severity level	as below	
Harmonic Current	EN61000-3-2	Class A		
ESD	EN61000-4-2	3	A	
Radiated	EN61000-4-3	3	A	
EFT	EN61000-4-4	3	A	
Surges	EN61000-4-5	Installation class 3	A	
Conducted	EN61000-4-6	3	A	
Dips and Interruptions	EN61000-4-11	Dip: 30% 10 ms	A	
		Dip: 60% 100 ms	B	
		Dip: 100% 5000 ms	B	
	SEMI F47			Compliant

## Electromagnetic Compatibility - Emissions

Table 8

Phenomenon	Standard	Test Level	Criteria	Notes & Conditions
Conducted	EN55022	Class A <sup>(1)</sup>		
Radiated	EN55022	Class A		
Voltage Fluctuations	EN61000-3-3			

1. Contact sales for class B conducted performance.

## Safety Agency Approvals

Table 9

Safety Agency	Safety Standard	Category
CB Report	CSA CB155548-2035526 IEC60950-1:2005 Ed 2	Information Technology
CSA	CSA certificate #2035528 CSA22.2 No. 60950-1-07	Information Technology
UL	UL File #139109 UL60950-1 (2007)	Information Technology
TUV	TUV Certificate #8 08 07 573960 51 EN60950-1:2006	Information Technology
CE	LVD	

Equipment Protection Class	Safety Standard	Notes & Conditions
Class I	IEC60950-1:2005 Ed 2	

## Mechanical Details

Figure 20

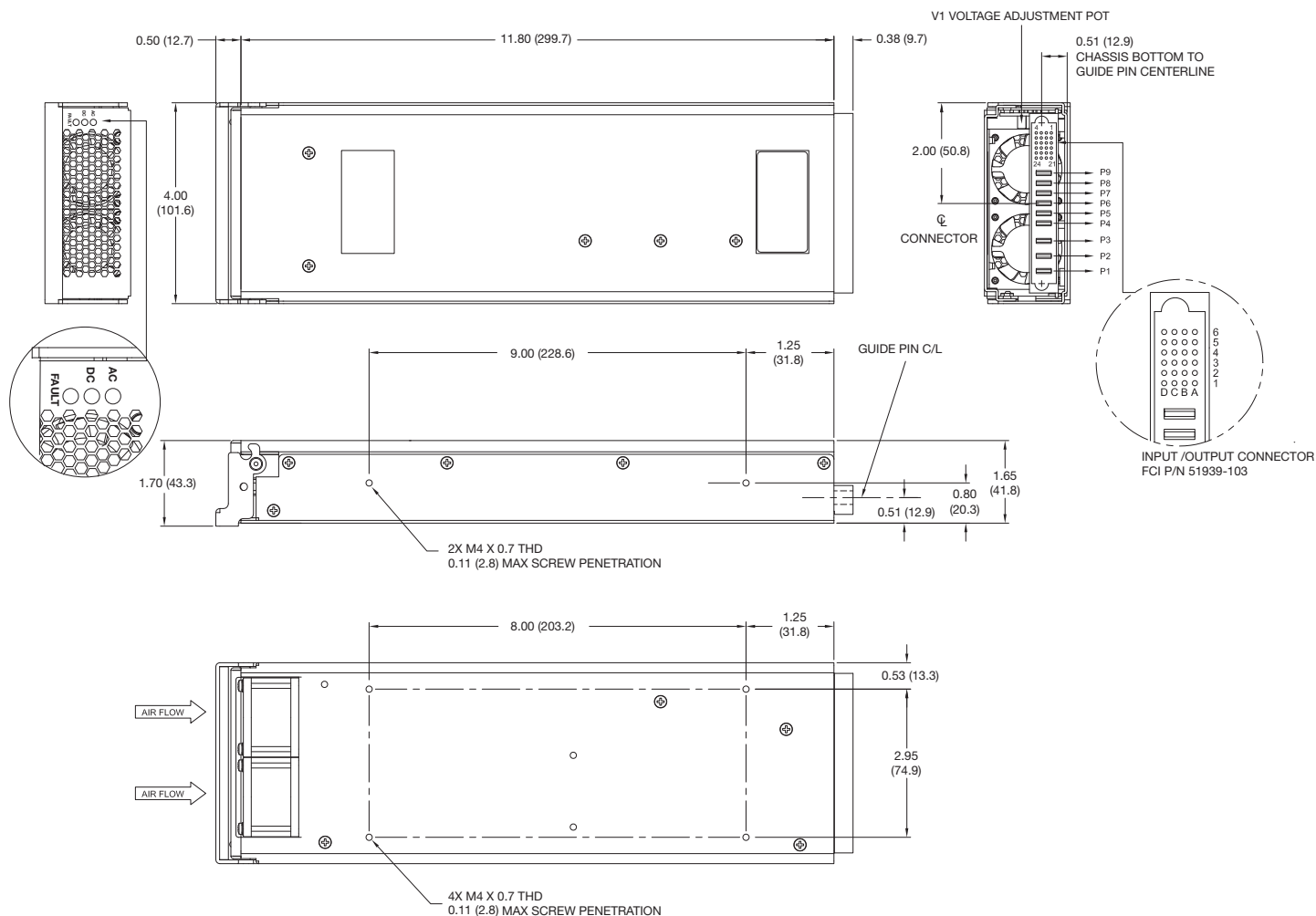

PIN CONNECTIONS			
Pin	Function	Pin	Function
A6	SIGNAL GND	A3	GA1 (I <sup>2</sup> C)
B6	DC OK	B3	GA0 (I <sup>2</sup> C)
C6	INHIBIT	C3	I <sup>2</sup> C GND
D6	FAULT	D3	PMB SDA (DATALINE)
A5	AC OK/POWER FAIL	A2	PMB SCL (CLOCK)
B5	ENABLE (48-56 V models)	B2	PWR ID
C5	NC	C2	V PROGRAM
D5	CURRENT MONITOR	D2	ENABLE (12-24 V models)
A4	NC	A1	CURRENT SHARE
B4	5V STANDBY RETURN	B1	NC
C4	5V STANDBY	C1	- SENSE
D4	GA2 (I <sup>2</sup> C)	D1	+ SENSE

PIN CONNECTIONS	
Pin	Function
P1	AC NEUTRAL
P2	AC LINE
P3	CHASSIS GND
P4	-VOUT
P5	-VOUT
P6	-VOUT
P7	+VOUT
P8	+VOUT
P9	+VOUT

**Notes:**

- All dimensions are in inches (mm).  
Tolerance: X.XX = ±0.02 (±0.50), X.XXX = ±0.01 (±0.25)
- Output connector: BERG/FCI P/N 51939-103LF  
Mating connector: BERG/FCI P/N 51866-025LF right-angle PCB receptacle or BERG/FCI P/N 51940-117LF verticle PCB receptacle.

Mating connector evaluation purposes.  
Contact Sales

# GFR1K5 Rack

## INSTALLATION INSTRUCTIONS

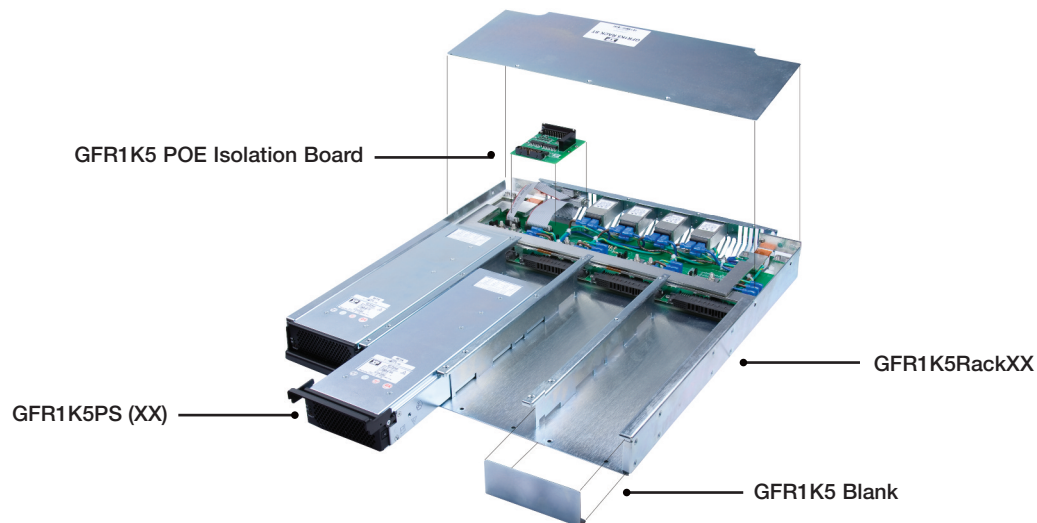

### **WARNING**

HAZARDOUS VOLTAGE AND ENERGY LEVELS ARE PRESENT WHICH CAN PRODUCE SERIOUS SHOCKS AND BURNS.

HIGH LEAKAGE CURRENT IS POSSIBLE, MAKE SURE EARTH CONNECTION IS ESTABLISHED BEFORE APPLYING AC.

DISCONNECT POWER BEFORE SERVICING.

DOUBLE POLE / NEUTRAL FUSING

# 1. SAFETY AND RECOMMENDED PRACTICES

## GENERAL PRACTICES

- For use in restricted access locations only.
  - Suitable for mounting over concrete or other non-combustible surfaces
  - Slide/rail mounted equipment is not to be used as a shelf or a workspace
- a) Elevated Operating Ambient – If installed in a closed or multi-unit rack assembly, the operating ambient temperature of the rack environment may be greater than room ambient. Therefore, consideration should be given to installing the equipment in an environment compatible with the maximum ambient temperature (Tmra 50°C) specified by the manufacturer.
- b) Reduced Air Flow – Installation of the equipment in a rack should be such that the amount of airflow required for safe operation of the equipment is not compromised.
- c) Mechanical Loading – Mounting of the equipment in the rack should be such that a hazardous condition is not achieved due to uneven mechanical loading. **WARNING: HIGH LEAKAGE CURRENT IS POSSIBLE. MAKE SURE EARTH CONNECTION IS ESTABLISHED BEFORE APPLYING AC.**

Only authorized, qualified, and trained personnel should attempt to work on this equipment. Refer to datasheets for full product specifications. Observe all local and national electrical, environmental and workplace codes.

- d) Circuit Overloading – Consideration should be given to the connection of the equipment to the supply circuit and the effect that overloading of the circuits might have on overcurrent protection and supply wiring. Appropriate consideration of equipment nameplate ratings should be used when addressing this concern.
- e) Reliable Earthing – Reliable earthing of rack-mounted equipment should be maintained. Particular attention should be given to supply connections other than direct connections to the branch circuit (e.g. use of power strips). The plug end of the AC cord is considered to be the primary disconnect means, and reasonable access must be given to the plug and receptacle area. The receptacle must be fed with a breaker or fuse according to table 10.

NOTE: Under-sizing the AC breaker and wiring could cause nuisance breaker trips and system outages. ALWAYS FOLLOW NEC RULES AND YOUR LOCAL COMPANY PRACTICES WHEN SELECTING WIRING AND PROTECTION

Table 10

Recommended AC Circuit Breaker and Wire Sizes						
Type of Feed	Model # of Power Module	Minimum Input Voltage (V)	Max P (W)	Max I (A)	Circuit Breaker Minimum Value to use (A)	90 °C Minimum Wire Gauge to use at 30 °C ambient (AWG)
Individual Feed	12 V	90	1200	16.15	20	12
		180	1200	8.20	15	14
	24 V	90	1200	15.97	20	12
		180	1500	10.00	15	14
	48 V	90	1200	15.60	20	12
		180	1500	9.80	15	14
	56 V	90	1200	15.58	20	12
		180	1500	9.80	15	14

CAUTION: ALL RECTIFIERS EMPLOY INTERNAL DOUBLE POLE / NEUTRAL FUSING

## Output Conditions

Table 11

Output Power	Output Voltage V1	Max Total Output Current V1	Output Voltage V2	Max Output Current V2	AC Input
1200 W	12 VDC	100 A	5 V	1 A	115 V/230 VAC
2400 W	12 VDC	200 A	5 V	2 A	115 V/230 VAC
3600 W	12 VDC	300 A	5 V	3 A	115 V/230 VAC
4800 W	12 VDC	400 A	5 V	4 A	115 V/230 VAC

Table 12

Output Power	Output Voltage V1	Max Total Output Current V1	Output Voltage V2	Max Output Current V2	AC Input
1500 W	24/48/56 VDC	63/31/27 A	5 V	1 A	230 VAC
3000 W	24/48/56 VDC	126/62/54 A	5 V	2 A	230 VAC
4500 W	24/48/56 VDC	189/96/81 A	5 V	3 A	230 VAC
6000 W	24/48/56 VDC	252/124/108 A	5 V	4 A	230 VAC

**CAUTION** SINGLE OUTPUT RACK: Use all rectifier units with the same rated output voltage.  
 DUAL OUTPUT RACK: Make sure that each output use rectifiers with the same output voltage rating.

Use double hole, UL Listed lugs for all DC connections to prevent lug rotation and inadvertent contact with other circuits. The maximum current draw per side is 200 A.

Reference table 13 to determine minimum wire sizes for all dc connections. In practice, loop voltage drop considerations will usually dictate larger than minimum safe wire size. Custom output buss bars should be considered for over 125A per side.

## Maximum Current Rating in Amperes

Table 13

Wire Gauge	Current (A)
12	30
10	35
8	50
6	70
4	90
2	125
1	150
0	200
00	225

## Torque Settings

Table 14 shows recommended torque settings for all mechanical and electrical connections according to screw or nut size.

Table 14

Recommended Torque Settings		
Fastner Size	Torque	
M3	5-6 In-lbs	0.058 - 0.069 kg-m
M3.5	9-10 In-lbs	0.104 - 0.115 kg-m
M4	12-14 In-lbs	0.138 - 0.161 kg-m
M5	24-28 In-lbs	0.276 - 0.322 kg-m
M6	44-50 In-lbs	0.507 - 0.576 kg-m

XP does not recommend shipping the rack with the power modules installed. Power modules should be shipped in separate boxes.

## Required Tools

XP Power power module rack is designed to be installed with a minimum number of commonly available tools:

- #1 & #2 Philips screwdrivers
- Torque wrench
- 5/16" and 7/16" box wrenches, sockets and/or nut drivers
- Wire and cable strippers
- Wire and cable crimpers

## Site and Equipment Preparations

After removing equipment from boxes and packaging material, inspect for shipping and / or other damage. Contact sale or technical support immediately if any damage is present. Have all tools, wire, cables, hardware, etc. within easy reach. To the extent possible, ensure a clean (free of debris, dust, foreign material etc.) work environment. Care should be taken in the installation process to prevent exposure of the equipment to wire clippings. If possible, the power modules should remain sealed in their shipping boxes until the shelf wiring is complete. Ensure all AC and DC power sources are off and disconnected.

## Power Plant Mounting and Wiring

This equipment is intended for normal operations and is to be installed in a standard 19" enclosure. It is recommended that one person lift the rack into place while another installs using the supplied hardware. Torque hardware according to Table 14.

Table 15

Model Number	Description
GFR1K5RACK01	1U Rack to parallel up to 4 GFR1K5 12V to 56V power supplies. Complete with mounting brackets and 3 blank plates, Class B.
GFR1K5RACK03	1U Rack to parallel up to 4 GFR1K5 48V or 56V power supplies to meet POE isolation requirements. Complete with mounting brackets and 3 blank plates. Class B.
GFR1K5RACK04	Provides dual output. 1U rack to parallel up to 2 GFR1K5 12V to 56V power supplies each side. Complete with mounting bracket and 2 blank plates. Class B.
GFR1K5RACK05	1U Rack to parallel up to 4 GFR1K5 12V to 56V power supplies to provide voltage free contacts for industrial applications. Complete with mounting brackets and 3 blank plates. Class B.
GFR1K5RACK06	1U Rack to parallel up to 4 GFR1K5 12V to 56V power supplies. Complete with mounting brackets and 3 blank plates, Class A.
GFR1K5RACK07	1U Rack to parallel up to 4 GFR1K5 48V or 56V power supplies to meet POE isolation requirements. Complete with mounting brackets and 3 blank plates. Class A.
GFR1K5RACK08	Provides dual output. 1U rack to parallel up to 2 GFR1K5 12V to 56V power supplies each side. Complete with mounting bracket and 2 blank plates. Class A.
GFR1K5RACK09	1U Rack to parallel up to 4 GFR1K5 12V to 56V power supplies to provide voltage free contacts for industrial applications. Complete with mounting brackets and 3 blank plates. Class A.

## GFR1K5 Rack - Input Characteristics

Notes and Conditions
Each GFR1K5 power supply within the rack is wired from a separate IEC320 inlet, the input characteristics therefore follow those for the individual GFR1K5 supplies detailed on page 2. The input power available at low voltage input is limited by the current available through the IEC320 inlet, see fig 21.

## Input Derating Curve

Figure 21

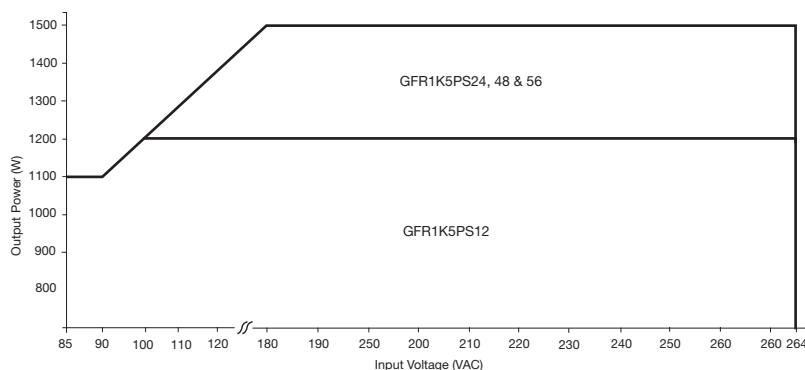

## GFR1K5 Rack - Configuration Tables

Table 16

Output Power	Output Voltage V1	Max Output Current V1	Output Voltage V2	Max Output Current V2	AC Input <sup>(1)</sup>	Model Numbers
1200 W	12 VDC	100 A	5 V	1 A	115 V/230 VAC	1 x GFR1K5PS12, 1 x GFR1K5RACK01
2400 W	12 VDC	200 A	5 V	2 A	115 V/230 VAC	2 x GFR1K5PS12, 1 x GFR1K5RACK01
3600 W	12 VDC	300 A	5 V	3 A	115 V/230 VAC	3 x GFR1K5PS12, 1 x GFR1K5RACK01
4800 W	12 VDC	400 A	5 V	4 A	115 V/230 VAC	4 x GFR1K5PS12, 1 x GFR1K5RACK01

Table 17

Output Power	Output Voltage V1	Max Output Current V1	Output Voltage V2	Max Output Current V2	AC Input <sup>(1)</sup>	Model Numbers <sup>(2)</sup>
1500 W	24/ 48/ 56 VDC	63/ 31 /27 A	5 V	1 A	230 VAC	1 x GFR1K5PS(XX), 1 x GFR1K5RACKXX
3000 W	24/ 48/ 56 VDC	126/ 62 /54 A	5 V	2 A	230 VAC	2 x GFR1K5PS(XX), 1 x GFR1K5RACKXX
4500 W	24/ 48/ 56 VDC	189/ 93 /81 A	5 V	3 A	230 VAC	3 x GFR1K5PS(XX), 1 x GFR1K5RACKXX
6000 W	24/ 48/ 56 VDC	252/124/108 A	5 V	4 A	230 VAC	4 x GFR1K5PS(XX), 1 x GFR1K5RACKXX

Table 18

Output Power	Output Voltage V1	Max Output Current V1	Output Voltage V2	Max Output Current V2	AC Input <sup>(1)</sup>	Model Numbers
1500 W	56 VDC	27 A	5 V	0.1 A	230 VAC	1 x GFR1K5PS56, 1 x GFR1K5RACK03
3000 W	56 VDC	54 A	5 V	0.2 A	230 VAC	2 x GFR1K5PS56, 1 x GFR1K5RACK03
4500 W	56 VDC	81 A	5 V	0.3 A	230 VAC	3 x GFR1K5PS56, 1 x GFR1K5RACK03
6000 W	56 VDC	100 A	5 V	0.4 A	230 VAC	4 x GFR1K5PS56, 1 x GFR1K5RACK03

1. See input derating chart from further information. See fig. 21 on page 14.

2. Replace (XX) in model number with required GFR1K5 output voltage & rack. All voltages must be the same in the standard rack as outputs are parallel, consult sales for alternate rack configurations.

## Rock Jumper Configuration

Table 19

Rack Model	Output Voltage	Enable								5 V Standby	
		JP1	JP2	JP3	JP4	JP5	JP6	JP7	JP8	JP9	JP10
01	12-24 V	1-2, 3-4, 5-6	1-2, 3-4	1-2, 5-6	1-2	3-4	3-4	3-4	3-4		
	48-56 V	1-2, 3-4, 5-6	1-2, 3-4	1-2, 5-6	1-2	1-2	1-2	1-2	1-2		
03	12-24 V	1-2, 3-4, 5-6	1-2, 3-4	1-2, 5-6	1-2	3-4	3-4	3-4	3-4	1-2	
	48-56 V	1-2, 3-4, 5-6	1-2, 3-4	1-2, 5-6	1-2	1-2	1-2	1-2	1-2	1-2	
04	12-24 V	1-2, 3-4, 5-6	1-2, 3-4	1-2, 5-6	1-2	3-4	3-4	3-4	3-4	1-2	1-2
	48-56 V	1-2, 3-4, 5-6	1-2, 3-4	1-2, 5-6	1-2	1-2	1-2	1-2	1-2	1-2	1-2
05	12-24 V	1-2, 3-4, 5-6	1-2, 3-4	1-2, 5-6	1-2	3-4	3-4	3-4	3-4	1-2	
	48-56 V	1-2, 3-4, 5-6	1-2, 3-4	1-2, 5-6	1-2	1-2	1-2	1-2	1-2	1-2	
06	12-24 V	1-2, 3-4, 5-6	1-2, 3-4	1-2, 5-6	1-2	3-4	3-4	3-4	3-4		
	48-56 V	1-2, 3-4, 5-6	1-2, 3-4	1-2, 5-6	1-2	1-2	1-2	1-2	1-2		
07	12-24 V	1-2, 3-4, 5-6	1-2, 3-4	1-2, 5-6	1-2	3-4	3-4	3-4	3-4	1-2	
	48-56 V	1-2, 3-4, 5-6	1-2, 3-4	1-2, 5-6	1-2	1-2	1-2	1-2	1-2	1-2	
08	12-24 V	1-2, 3-4, 5-6	1-2, 3-4	1-2, 5-6	1-2	3-4	3-4	3-4	3-4	1-2	1-2
	48-56 V	1-2, 3-4, 5-6	1-2, 3-4	1-2, 5-6	1-2	1-2	1-2	1-2	1-2	1-2	1-2
09	12-24 V	1-2, 3-4, 5-6	1-2, 3-4	1-2, 5-6	1-2	3-4	3-4	3-4	3-4	1-2	
	48-56 V	1-2, 3-4, 5-6	1-2, 3-4	1-2, 5-6	1-2	1-2	1-2	1-2	1-2	1-2	

Table 20

Characteristics	Minimum	Typical	Maximum	Units	Notes and Conditions
The outputs of all GFR power supplies are wired in parallel via bus bars to provide a single combined output as shown in the configuration tables.					

## General Specifications

Table 21

Characteristic	Minimum	Typical	Maximum	Units	Notes & Conditions
Isolation: Input to Output	3000/4000			VAC	12-24 V models / 48-56 V models
Input to Ground	1500			VAC	
Output to Ground	500 / 1500			VDC / VAC	GFR1K5RACK01 / GFR1K5RACK03
Output to Signals	1500			VAC	GFR1K5RACK03
Signals to Ground	1500			VAC	GFR1K5RACK03
Weight		12 (5.5)		lb (kg)	Rack only

## Safety Agency Approvals

Table 22

Safety Agency	Safety Standard	Category
CB Report	COMPLETED	Information Technology
UL	Listed	Information Technology
CE	LVD	

## Signals & Control

Table 23

Characteristic	Notes & Conditions
<b>Signals &amp; Control</b>	
AC OK	Up to 4 separate AC OK signals, one per installed power supply - AC OK is an opto isolated transistor referenced to logic ground providing a minimum of 3 ms warning of loss of output regulation. The signal is fully isolated and the collector and emitter must be connected externally. The transistor is normally on when AC is healthy. See fig. 6 & 16.
DC OK	Up to 4 separate DC OK signals, one per installed power supply - DC OK is an opto isolated transistor referenced to logic ground providing warning of loss of output. The signal is fully isolated and the collector and emitter must be connected externally. The transistor is normally on when output DC is healthy. See fig. 7 & 16.
Inhibit	Up to 4 separate Inhibit inputs, one per installed power supply - Floating isolated optocoupler diode referenced to logic ground powered diode inhibits the supply. See fig. 8 & 17.
Enable	The Enable pin is an integral rack connection and is the last to mate and holds the power supply off until the unit is fully plugged in. No external customer connection.
Fault	Up to 4 separate Fault signals, one per installed power supply - Fault is an opto floating isolated transistor referenced to logic ground providing warning of output voltage below 90% of nominal, fan fault or overtemperature. The signal is fully isolated and the collector and emitter must be connected externally. The transistor is normally on when there is no fault. See fig. 9.
Current Share	The current share connection of each installed power supply are parallel connected within the rack and referenced to logic ground. This connection is also available as a customer connection to parallel up to 2 racks. Units share current within 10% of each other at full load. Derate output to 90% of total combined load. See fig. 12 & 15.
Current Monitor	Enables the monitoring of supplied current from V1 output of each installed power supply. See fig. 11.
I <sup>2</sup> C	The I <sup>2</sup> C PMBus compatible interface can be used for monitoring the unit output voltage, current, internal temperature and run time. It can also be utilized to turn the unit on and off, detect faults along with identification of the unit model number and serial number. A separate application note is available detailing the use of this interface, contact sales for further information.
5V Standby (V2)	5 V / up to 4 A (up to 0.4 A when POE board installed) supply, always present when AC supplied.

## Environmental

Table 24

Characteristic	Minimum	Typical	Maximum	Units	Notes & Conditions
Operating Temperature	-20		+70	°C	Derate linearly from +50 °C at 2.5%/°C to 50% at 70 °C. See fig. 22.
Storage Temperature	-40		+85	°C	
Warm up time		20		Minutes	
Cooling				CFM	2 integral fans per power supply.
Humidity	5		95	%RH	Non-condensing
Operating Altitude			3000	m	
Shock					3 x 30 g/11 ms shocks in both +ve & -ve directions along the 3 orthogonal axis, total 18 shocks.
Vibration					Single axis 10-500 Hz at 2 g x 10 sweeps

## Temperature Derating Curves

Per installed power supply

Figure 22

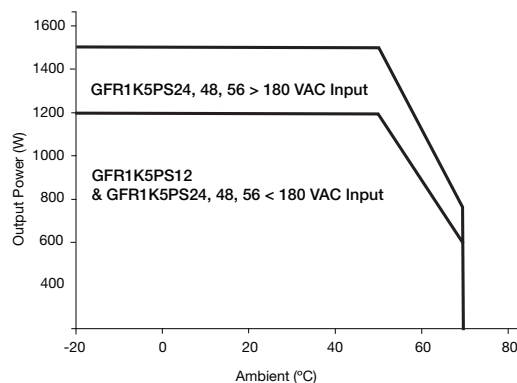

## Mechanical Details

Figure 23

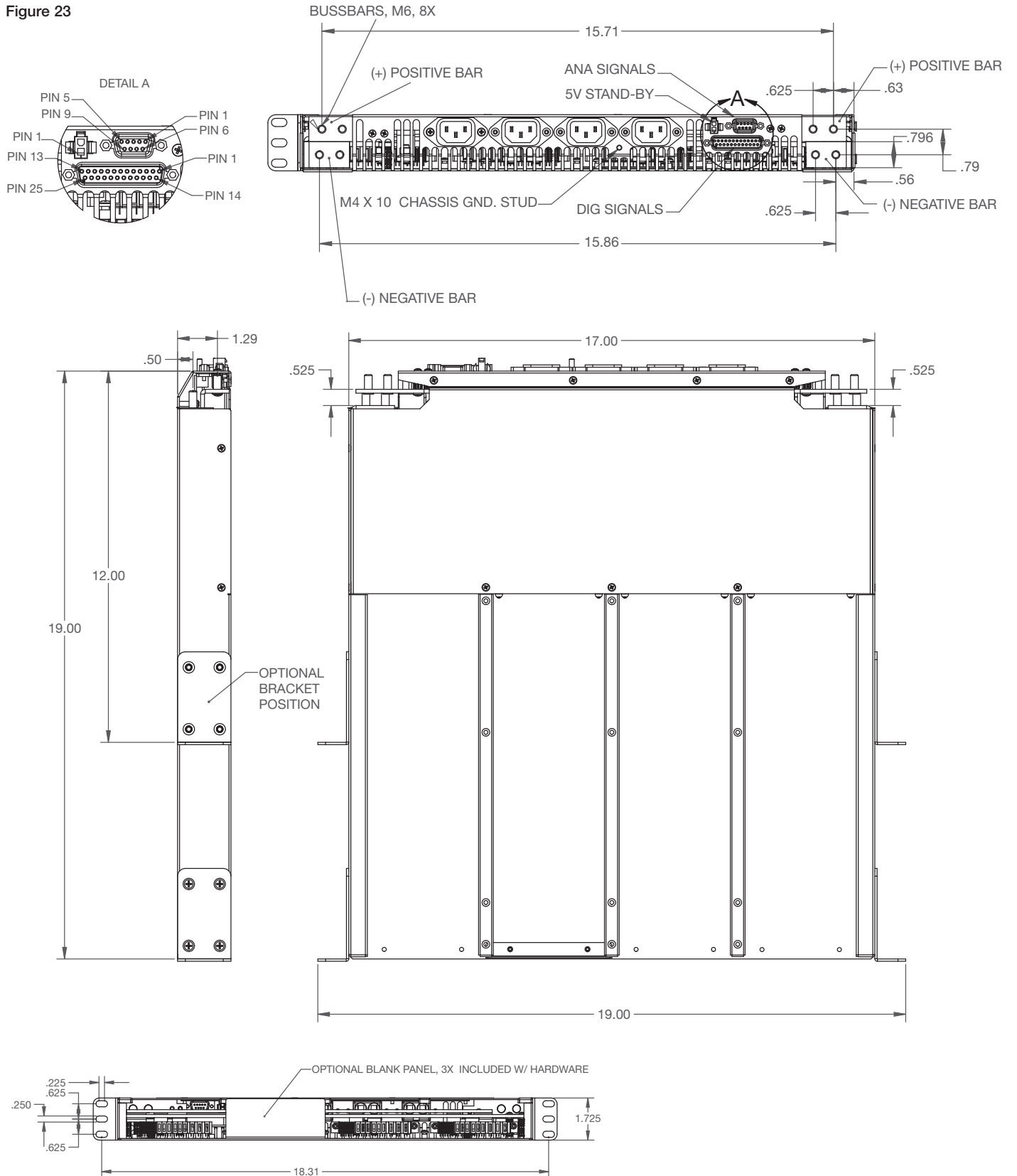

**Mechanical Details**  
Option 01, 03, 05, 06,  
07, 09

Figure 24

9 Way 'D' Type Connector

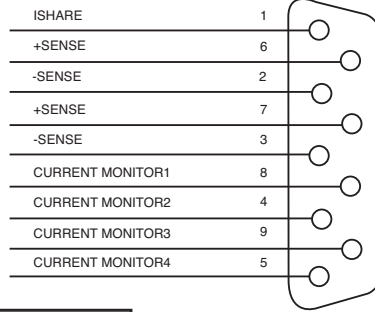

5 V Standby	
Pin	Function
1	5 V Standby
2	5 V Standby RTN

Mates with: Molex 39-01-2020 HSG  
Molex 39-00-0039 PIN

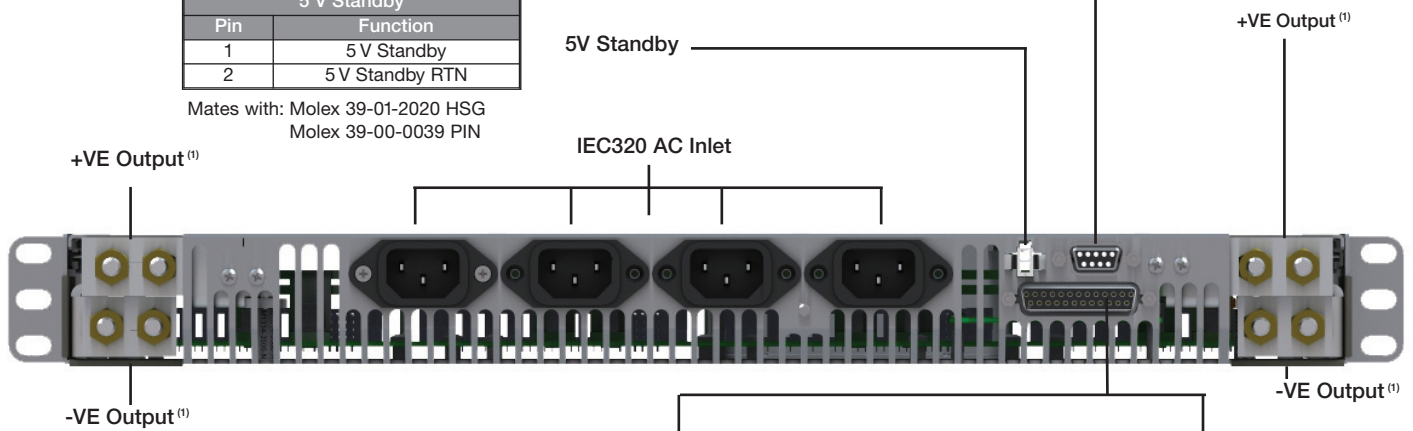

**01, 03, 06, 07**

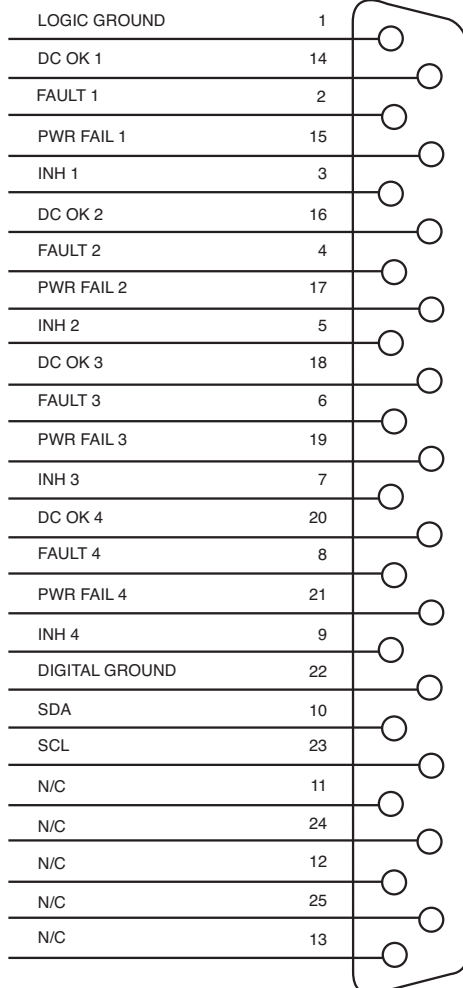

**05, 09**

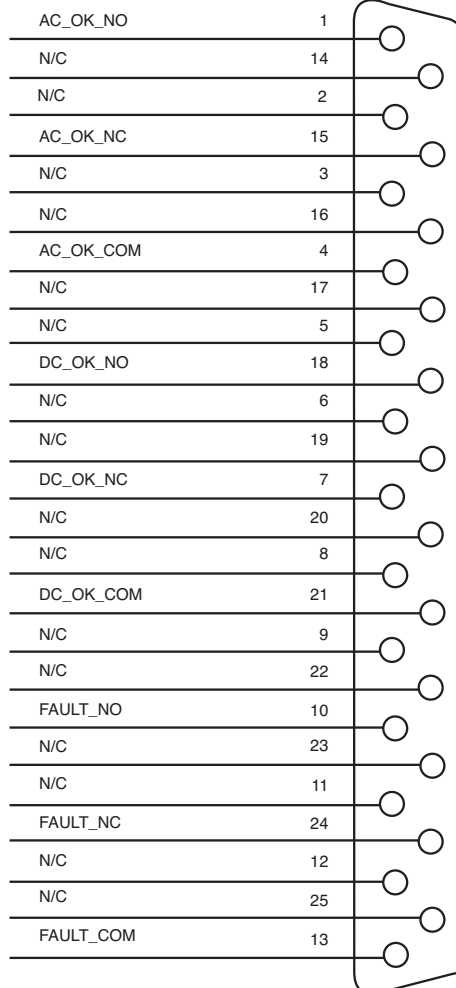

**D Conn  
25**

**Digital Signals - Logic Ground**

- The output bus bar connections should be loaded symmetrically for optimum thermal and regulation performance. Maximum current per side is limited to 200 A with 01 rack models and 125 A with 02 & 03 rack models.

## Mechanical Details Option 04, 08 (Dual Output)

Figure 25

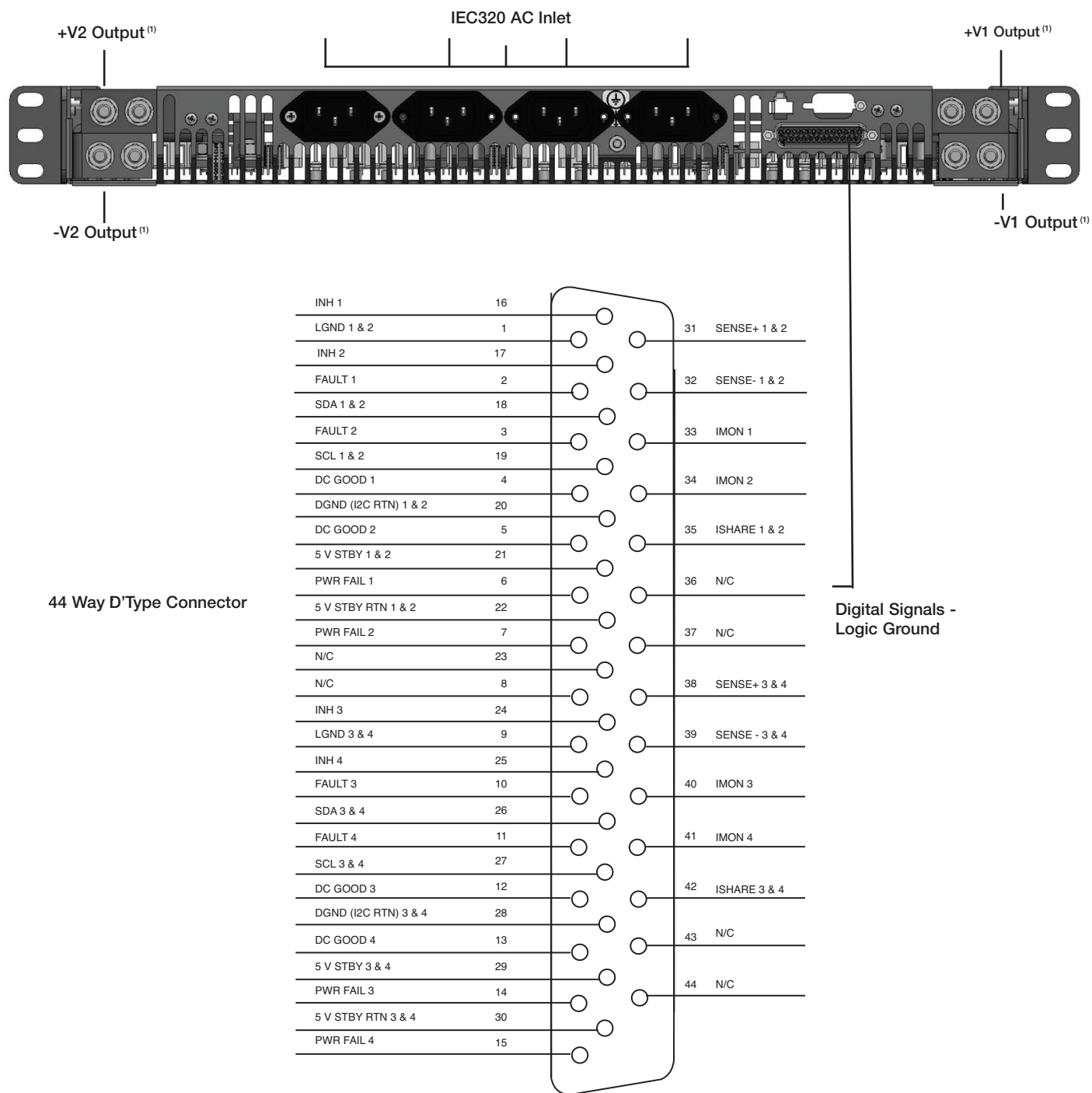

1. Maximum current per side is limited to 200 A with 04 rack models

## Test and Turn-Up

### Power Up

Once all AC and DC connectors have been secured and checked, install each power module, by sliding and latching each power module into a rack position as shown in figure 26. The power module latches must be open for installation. Attempting to install the power modules with the latches closed will result in mechanical damage to the power modules and the rack. After startup, fan speed will settle within 10 seconds.

Figure 26

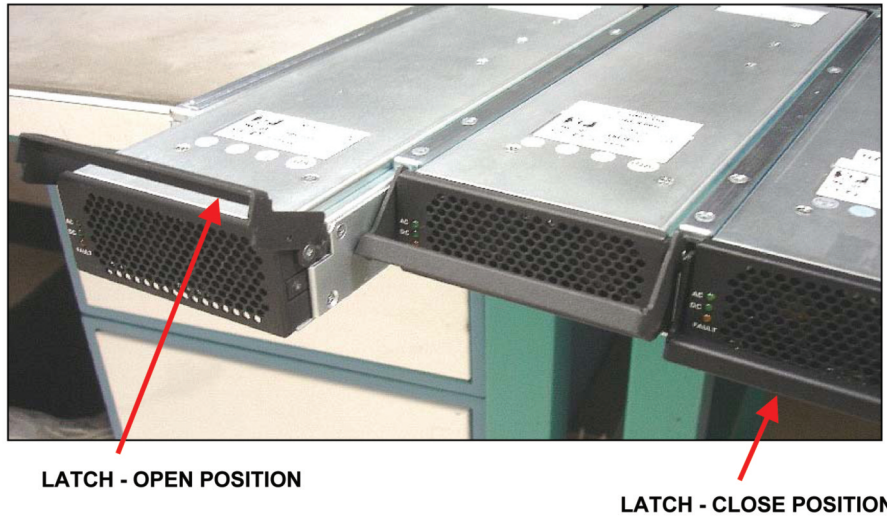

LATCH - OPEN POSITION

LATCH - CLOSE POSITION

## Troubleshooting - problems and solutions

The modular plug-n-play nature makes diagnostics very easy. Make sure that all power modules are properly seated and latched into their respective slots. Make sure that all power and signal connections are properly mated. Table 25 lists problems and potential solutions.

Each power modules will have 3 LED

- DC OK LED "ON" indicates main O/P is within specification.
- AC OK LED "ON" indicates a healthy AC with PFC present.
- Fault LED "OFF" indicates a good power modules.
- Fault LED "ON" means no DC output, thermal shutdown or power supply inhibit mode.

Table 25

Problem	Problem Indicator	Suggest Action
Fault LED "ON"		Make sure power supply is not inhibited, replace power module
DC OK LED "OFF"		
AC OK LED "OFF"		Make sure AC is plugged in, replace power module
All LED "OFF"		Check input line or circuit breaker

Recommended current share and sensing circuit, if customer is using their rack and their backplane.

Figure 27

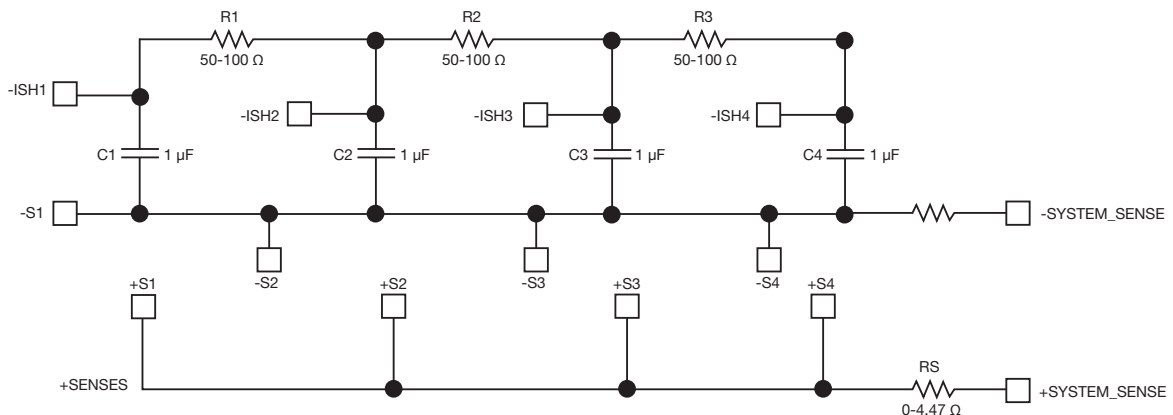

# GFR1K5 - Application Note

## PMBus Interface



### Interface Levels (Physical Layer)

The interface levels are open drain (with pull-ups installed inside the rectifier on the SDA and SCL lines). The address bits A0, 1, and 2 are pulled up internally to +5 VDC through 10 KOhm resistors so that in order to select the lower three bits of address information, the address bit needs to be left open (a "1") or grounded (a "0").

All ground references for the PMBus interface are to pin 15 (Signal Ground) on the I/O connector. System level bypassing of SCL and SDA lines may be required in order to reduce bus noise levels. We recommend a bus capacitance of 220 pF on the host system (other capacitance may work and is more system layout dependent than any thing else). We recommend a maximum data rate of 100 Kbps.

### Address Byte

The address for the PMBus interface is set by a combination of fixed device type bits (A6 – A3) and floating address bits (A2 – A0). The device address byte definition is shown below:

Bit	7	6	5	4	3	2	1	0
Level	H	L	H	H	X	X	X	X
Address Bits	A6	A5	A4	A3	A2	A1	A0	R/W

X = H or L

The floating address bits are connected to the back-plane interface and pulled high via 10 kOhm resistors. This allows for up to eight power supplies to be addressed individually by leaving the address bits open (high) or grounded (low). The table below shows all of the PMBus address combinations:

A2	A1	A0	PMBus Write Address (Hex)	PMBus Read Address (Hex)
L	L	L	b0	b1
L	L	H	b2	b3
L	H	L	b4	b5
L	H	H	b6	b7
H	L	L	b8	b9
H	L	H	ba	bb
H	H	L	bc	bd
H	H	H	be	bf

The addressing is similar to the Group Command Protocol without PEC as mentioned in the PMBus standard.

Addresses are continually read at a once per five second rate . Changing an address once the unit is powered up will affect the unit's address. Addresses will not be latched.

## Supported PMBus Protocols

The PMBus slave interface supports Read/Write Byte, Read/Write Word, and Read/Write Block protocols as defined in the PMBus specification. The figures below are from the PMBus specification and are repeated here for convenience. A write to a read-only command is ignored.

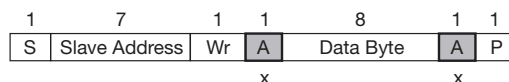

KEY			
S	Start Condition	A	Acknowledge (this bit position may be '0' for an ACK or '1' for a NACK)
Sr	Repeated Start Condition	P	Stop Condition
Rd	Read (bit value of 1)	PEC	Packet Error Code
Wr	Write (bit value of 0)	□	Master-to-Slave
x	Shown under a field indicates that that field is required to have the value of 'x'	■	Slave-to-Master
		...	Continuation of Protocol

## Byte Protocols:

Write Byte Protocol:

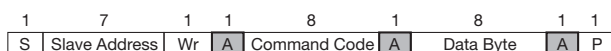

Read Byte Protocol:

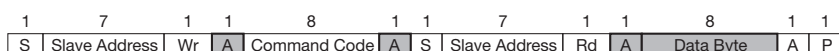

## Word Protocols:

Write Word Protocol:

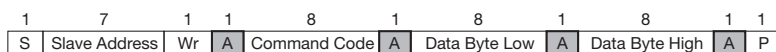

Read Word Protocol:

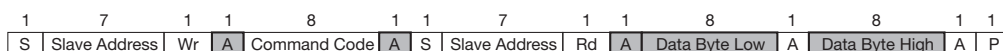

## Block Protocols:

### Block Write:

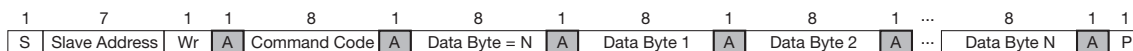

### Block Read:



## Data Registers (Standard Data Responses)

The data registers inside the unit are divided into two types: 1) read only data and 2) R/W data. Therefore, the R/W bit in the address byte needs to be set high in order to read the status bytes, or set low in order to write data into the status bytes.

The first byte of a Write Byte/Word access is the command code. The next one or two bytes are the data to be written. In this example, the master asserts the slave device address followed by the write bit. The device acknowledges, and then the master delivers the command code. The slave again acknowledges before the master sends the data byte or word (low byte first). The slave acknowledges each byte, and the entire transaction is finished with a STOP condition.

### Write Word Protocol:

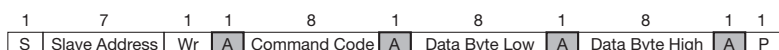

Reading data is slightly more complicated than writing data. First the host must write a command to the slave device. Then the host must follow that command with a repeated START condition to denote a read from that device's address. The slave then returns one or two bytes of data.

Note that there is no STOP condition before the repeated START condition, and that a NACK signifies the end of the read transfer.

### Read Word Protocol:

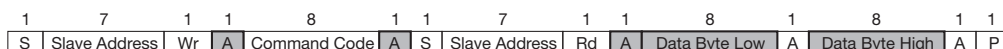

### Alarm Data Register (STATUS\_WORD) (Register 79h) Read Example

Master to Power Supply Data									Power Supply to Master Data	
Start	Address Byte								ACK	
S	1	0	1	1	x	x	x	0	A	
	A6	A5	A4	A3	A2	A1	A0	r/w		

Master to Power Supply Data								Power Supply to Master Data			
CMD Data								ACK			
0	1	1	1	1	1	0	1	A			
Status Byte 79h											

Master to Power Supply Data									Power Supply to Master Data								
Start	Address Byte								ACK	Register Information (Low Byte)							
S	1	0	1	1	x	x	x	1	A	0	0	1	1	x	x	x	1
	A6	A5	A4	A3	A2	A1	A0	r/w		P7	P6	P5	P4	P3	P2	P1	P0

Master to Power Supply Data		Power Supply to Master Data								Master to Rectifier Data		
ACK		ACK	Register Information (Low Byte)								ACK	STOP
A		A	0	0	1	1	x	x	x	1	A	P
			P7	P6	P5	P4	P3	P2	P1	P0		

## Data Registers (Inventory Data Responses)

PMBus Block Write and Block Read commands are used to write and retrieve inventory information. The Block Write and Read commands require that the first data byte is the number of data bytes to follow (Byte Count).

The Block Write begins with a slave address and a write condition. After the command code, the host issues a byte count which describes how many more bytes will follow in the message. If a slave has 20 bytes to send, the byte count field will have the value 20 (14h), followed by the 20 bytes of data. The byte count does not include the PEC byte. The byte count may not be zero. A Block Read or Write is allowed to transfer a maximum of 32 data bytes.

### Block Write:



A Block Read differs from a block write in that the repeated START condition exists to satisfy the requirement for a change in the transfer direction. A NACK immediately preceding the STOP condition signifies the end of the read transfer.

### Block Read:



Manufacturer ID (Register 99h) Read Example:

Master to Power Supply Data									Power Supply to Master Data	
Start	Address Byte								ACK	
S	1	0	1	1	x	x	x	0	A	
	A6	A5	A4	A3	A2	A1	A0	r/w		

Master to Power Supply Data								Power Supply to Master Data	
CMD Data								ACK	
1	0	0	1	1	0	0	1	A	
Manufacturer ID Byte 99h									

Master to Rectifier Data									Power Supply to Master Data								
Start	Address Byte								ACK	Byte Count = 8 (08h)							
S	1	0	1	1	x	x	x	1	A	0	0	0	0	1	0	0	0
	A6	A5	A4	A3	A2	A1	A0	r/w		8 Bytes of Data							

Master to Power Supply Data		Power Supply to Master Data								Master to Rectifier Data		
ACK		ACK	Data Byte 1 (58h)								ACK	
A		A	0	1	0	1	1	0	0	0	A	
			ASCII "X"									

Master to Rectifier Data		Power Supply to Master Data								Master to Rectifier Data		
ACK		ACK	Data Byte 2 (50h)								ACK	
A		A	0	1	0	1	0	0	0	0	A	
			ASCII "P"									

Power Supply to Master Data				Master to Rectifier Data				Power Supply to Master Data									
ACK	Data Byte 3 (5Fh)							ACK									
A	0	1	0	1	1	1	1	A	A	0	1	0	1	0	0	0	0
	ASCII "_"								ASCII "P"								

Master to Rectifier Data		Power Supply to Master Data								Master to Rectifier Data		
ACK		ACK	Data Byte 5 (4Fh)								ACK	
A		A	0	1	0	0	1	1	1	1	A	
			ASCII "O"									

Power Supply to Master Data				Master Rectifier Data				Power Supply to Master Data									
ACK	Data Byte 6 (57h)							ACK									
A	0	1	0	1	0	1	1	A	A	0	0	1	0	0	1	0	1
	ASCII "W"								ASCII "E"								

Master to Rectifier Data		Power Supply to Master Data								Master to Rectifier Data			
ACK		ACK	Data Byte 8 (52h)								ACK		STOP
A		A	0	1	0	1	0	0	1	0	A		P
			ASCII "R"										

The status data registers are defined as shown below:

Status Register CMD (hex)	Function	Protocol Type (R = Read / W = Write)	Number of Bytes
01h	On / Off Command (OPERATION)	Byte (R/W)	1 Read / Write
46h	Current Limit (in percent) (IOUT_OC_FAULT_LIMIT_)	Word (R/W)	2 Read / Write
47h	Current Limit Fault Response (IOUT_OC_FAULT_RESPONSE)	Byte (R/W)	1 Read / Write
79h	Alarm Data Bits (STATUS_WORD)	Word (R Only)	2 Read Only
8Bh	Output Voltage (READ_VOUT)	Word (R Only)	2 Read Only
8Ch	Output Current (READ_IOUT)	Word (R Only)	2 Read Only
8Dh	Power Supply Ambient Temp (READ_TEMPERATURE_1)	Word (R Only)	2 Read Only
9Ah	Unit Model Number (MFR_MODEL)	Block (R/W)	10 Read / Write plus byte count
9Eh	Unit Serial Number (MFR_MODEL)	Block (R/W)	8 Read / Write plus byte count
99h	Unit Manufacturer ID (MRF_ID)	Block (R/W)	8 Read / Write plus byte count
D0h	Unit Run Time Information (MFR_SPECIFIC_00)	Block (R Only)	4 Read Only plus byte count
B0h	User Data 1 (USER_DATA_00)	Block (R/W)	4 Read / Write plus byte count
B1h	User Data 2 (USER_DATA_01)	Block (R/W)	4 Read / Write plus byte count
B2h	User Data 3 (USER_DATA_02)	Block (R/W)	4 Read / Write plus byte count
B3h	User Data 4 (USER_DATA_03)	Block (R/W)	4 Read / Write plus byte count
B4h	User Data 5 (USER_DATA_04)	Block (R/W)	4 Read / Write plus byte count
B5h	User Data 6 (USER_DATA_05)	Block (R/W)	4 Read / Write plus byte count
B6h	User Data 7 (USER_DATA_06)	Block (R/W)	4 Read / Write plus byte count
B7h	User Data 8 (USER_DATA_07)	Block (R/W)	4 Read / Write plus byte count

## (OPERATION) On / Off Command 01h

The OPERATION command is used to turn the unit on and off in conjunction with the input from the Enable pin. The unit stays in the commanded operating mode until a subsequent OPERATION command instructs the device to change to another mode. At power up the rectifier will turn the unit on and keep it on until told to do otherwise. The contents of this register can be written and read to, but will not be maintained through a power cycle (all reset to normal operation when power is cycled).

The table below shows the command bits and what they do in the operation command.

Bits 7:6	Bits 5:6	Bits 3:2	Bits 1:0	Units On/Off
00	XX	XX	XX	OFF
01	XX	XX	XX	OFF
10	00	XX	XX	ON
10	01	01	XX	ON
10	01	10	XX	ON
10	10	01	XX	ON
10	10	10	XX	ON

## (IOUT\_OC\_FAULT\_LIMIT) Current Limit Set Point 46h

The IOUT\_OC\_FAULT\_LIMIT command sets the value of the output current, in percents, that causes the over-current detector to indicate an over-current fault condition. The two data bytes are HEX representation of the decimal in percentage, ie. 120% current limit, DEC2HEX (120d) = 0078h. Once an over-current occurred, the power supply will go to hiccup mode, OFF-time = 10 ms, On-time = 100 ms.

## (IOUT\_OC\_FAULT\_RESPONSE) Current Limit Fault Response 47h

The IOUT\_OC\_FAULT\_RESPONSE command instructs the device on what action to take in response to an output over-current fault. The register function is given below:

Bits	Description	Value	Meaning
7:6	Response to OC Trip	00	Do nothing, continue to supply output voltage until hardware OC trip point activates, (Default setting).
		01	Do nothing, continue to supply output voltage until hardware OC trip point activates, (Default setting).
		10	Do nothing, continue to supply output voltage until hardware OC trip point activates, (Default setting).
		11	The power supply shuts down and responds as programmed by the Retry setting in bits 5:3.
5:3	Retry Setting	000	A zero value for the retry setting means that the unit does not attempt to restart. The output remains disabled until the fault is cleared as mentioned in the Status/Control section.
		001-110	The power supply attempts to restart the number of times set by these bits. The minimum number $i \leq 1$ (001) and the maximum number is 6 (110). The on time for the retries is set at 10 ms. If the unit turns on during the retry the fault is cleared and the unit operation normally. Once the number of retries is reached the unit shuts down until the fault is cleared as mentioned in the Status/Control Section.
		111	The power supply attempts to restart continuously without limitation until it is commanded to turn off via the On/Off command (01h register) or AC power is cycled.
2:0	Delay Time	000-111	Not implemented.

## Resetting the over-current function

There are two ways to get the power supply out of the over-current mode once the unit has latched off:

1. Cycle the AC input power.
2. Using the ON/OFF command from the OPERATION (01h) register.

If the power supply is in continuous retry mode, the supply will turn back to normal operations if the load is decreased below the over-current fault limit setting.

## (STATUS\_WORD) Alarm Data 79h

Byte set (1) indicates a true condition bit cleared; (0) equals a false condition.

Low Byte

Bit	7	6	5	4	3	2	1	0
Data Bits	P7	P6	P5	P4	P3	P2	P1	P0

P6 = Off (the output is turned off for any reason such as disabled or faulted) 1 = fault (off), 0 = good (on)

P4 = IOUT\_OC (An over-current fault has occurred) 1 = fault, 0 = good

P3 = VIN\_UV (input under-voltage fault has occurred) 1 = fault (input under-voltage), 0 = good (input OK)

P2 = Temperature (an over temperature fault or warning has occurred) 1 = fault (over-temp), 0 = good (temperature OK)

P1 = Fault (Combination of AC-OK, DC-OK and Fan Fault) 1 = fault, 0 = good

High Byte

Bit	7	6	5	4	3	2	1	0
Data Bits	P7	P6	P5	P4	P3	P2	P1	P0

P7 = V\_OUT (an output voltage fault or warning has occurred) 1 = fault (DC output out of spec), 0 = good (DC output OK)

P5 = V\_IN (an input voltage fault or warning has occurred) 1 = fault (input under-voltage), 0 = good (input OK)

P3 = P\_GOOD (the power good signal is negated power not good) Uses an "OR" function for the DC\_OK OR AC\_OK signals.

If either signal is a 1, set this bit to a "1".

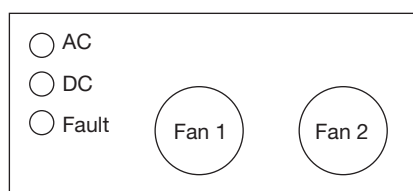

P2 = Fan 1 Fault, 1 = Fault, 0 = Good

P1 = Fan 2 Fault, 1 = Fault, 0 = Good

Literal data format:

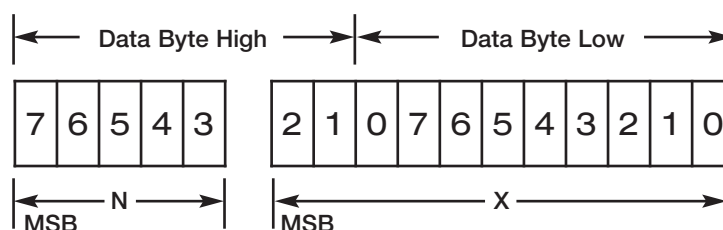

The relationship between X, N and the value communicated is:  $Y = X \cdot 2^N$ . Where, as described above: Y is the value being communicated, X is an 11 bit, two's complement integer, and N is a 5 bit, two's complement integer. To calculate the current or voltage from PMBus read out:

1. Extract N value from the PMBus read out, N is a fixed integer. The resulting 11 bits equals  $X \cdot 2^N$
2. Solving for X.  $N = -4$ . Converting X (11 bits binary) to decimal and multiply by  $2^N$  to derive the communicated data.

48V IOUT rectifier example max value = A3FF

$N = -4$  (10100 first 5 bits of the word),  $X = 2047$  (011,1111,1111 last 11 bits of the word)  $1023 \cdot 2^{-4} = 63.96 \text{ A}$

## (READ\_TEMPERATURE\_1) Power Supply Ambient Temperature 8Dh

Temperature is read from the temperature sensor located in the GFR1K5 near the rear left hand corner (as viewed from the front panel). The temperature is represented as a direct data formatted 2's complement number. This data will be in HEX representation of the degree in Celsius as shown in the examples below:

19h = 25 degrees Celsius

32h = 50 degrees Celsius

## (READ\_VOUT) Output Voltage Reading 8Bh

VOUT+ internal voltage level - a 2 byte word scaled from A000h = 0 VDC to A406h VOUT (64.375 V) max. This data will be in the literal data format. This is the voltage inside the or'ing devices. N Value = -4 for all voltages.

## (READ\_IOUT) Output Current Reading 8Ch

Output current level - a 2 byte word scaled as shown in the table below. This data will be in there Literal data format.

Rectifier Volt	Min Hex Value	Min Dec Value	Max Hex Value	Max Dec Value	N Value
12 V	9000h	0 A	9230h	140.00 A	-2
24 V	9800h	0 A	9ABCh	87.50 A	-3
48/56 V	A000h	0 A	A3FFh	63.93 A	-4

## (MFR\_MODEL) Power Supply Model Number 9Ah

Unit Model Number – returns a 10 ASCII character string that defines the rectifier model number (e.g. GFR1K5PS12, GFR1K5PS48)

## (MFR\_SERIAL) Power Supply Serial Number 9Eh

Unit Serial Number – returns an 8 ASCII character string that defines the rectifier serial number in the format YYWWXXXX = two bytes of the year (2006 = 06), two bytes of the week of the year (00 - 52), four bytes of the unit number produced that week (0000 - 9999).

## (MRF\_ID) Power Supply Manufacturer ID 99h

Unit Manufacturer – returns an 8 ASCII character string that defines the rectifier manufacturer name (e.g. XP\_POWER).

## (MFR\_SPECIFIC\_00) Power Supply Run Time D0h

Unit Run Time Information – returns a 4 byte Hex number that is the number of total seconds that the rectifier has operated (had AC power applied). Full scale is approximately 1,200,000 hours (136 years).

## (USER\_DATA\_00 thru 07) User data sections 0 – 7 B0 – B7h

User data words – 4 bytes of data that the user can read and write as needed.