

DIGI3201 Ethernet Interface



Power Supply not included.

Compatible Power Supply Series

CPS-i2000	CPS-EX2000	CPS-EP2000
CPS-i3000	CPS-EX3000	CPS-EP3000

Features:

- Configuration with standard Web Browser
- Single Module or Master & Slave Multi Array configuration
- Current Share Bus Power Distribution
- Microsoft compatible WIN10 WIN11 Driver

Operation Manual

CONTENT		Page
SIGNALLING	1.1 LED Signalling	3
RESETTING	1.2 Reset-Button	3
SETTING	1.3 DIP-Switch Settings	3
	1.4 Browser Settings	4
CONTROL CONNECTIONS	2.1 Inhibit Connection INH	8
	2.2 Ethernet Connection	8
	2.3 Current Share Connection	8
	2.4 Sense Connection	8
HARDWARE INSTALLATION		9
TECHNICAL DETAILS and LINE INSTALLATION		11
COMMAND LIST		13

1.1 LED Signalling



GREEN LED	Flashes quickly at 1Hz when firmware running normally
RED LED	Flashes slowly at 0,5Hz when: - connectivity problem - Incompatible slave connected to the master (device from other series or with other output voltage). It will also flash at the Master-Master when the above issue occurs to a Slave-Master or with one of his slaves

1.2 RESET BUTTON



To reset the interface, press the RESET BUTTON for at least 5 seconds until the RED LED lights up shortly.
ATTENTION: Resetting the interface will also lead to a reset of the IP address to 192.168.100.100.

1.3 DIP-SWITCH SETTINGS

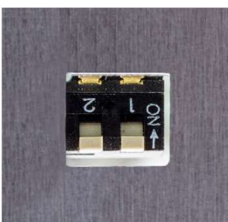

DIP-Switch 1	DIP-Switch 2	Function
OFF	OFF	Master (also use for single module operation)
ON	OFF	Slave
ON	ON	Slave-Master
OFF	ON	Master-Master

DIP-Switch position ON = Top
DIP-Switch position OFF= Below

1.4 BROWSER SETTINGS

1.4.1. Basic Settings

The screenshot shows a web browser window titled "Camtec Power Supply Interface" with the address bar displaying "192.168.100.100". The page features the Camtec logo and a navigation menu with tabs for "Device Settings", "Slaves", "Slave-Master", and "Device Status". The "Device Settings" tab is active, showing a "Device Information" section with fields for Firmware version (2.0.0), Device name, Product type (CPS-i3000.060), and MAC address (80:1F:12:6E:1E:6E). Below this is a "Network Configuration" section with fields for Device IP address (192.168.100.100) and Subnet mask (255.255.255.0). A "Save Settings and Reboot" button is located at the bottom of the configuration area. The footer of the page reads "© Copyright 2019-2022 MCD Elektronik GmbH".

To access the device enter the default IP address 192.168.100.100 into your browser.

Firmware version: Shows the installed firmware version
Device name: Assign free text up to 32 characters
Product type: Shows the detected power supply model
MAC address: Shows the MAC-address of the ethernet interface
Device IP address: Assign an IP-address xxx.xxx.xxx.xxx *** within the permitted range (factory address is 192.168.100.100)
Subnet mask: we recommend not to change the factory setting 255.255.255.0

*** Permitted IP-Address Range:
10.0.0.1 – 10.255.255.254
172.16.0.1 – 172.31.255.254
192.168.0.1 – 192.168.255.254

NOTE: No IP-address in the same physically network may be assigned twice. This is also the case for other devices than Camtec power supply units.

1.4.2. Slaves Table

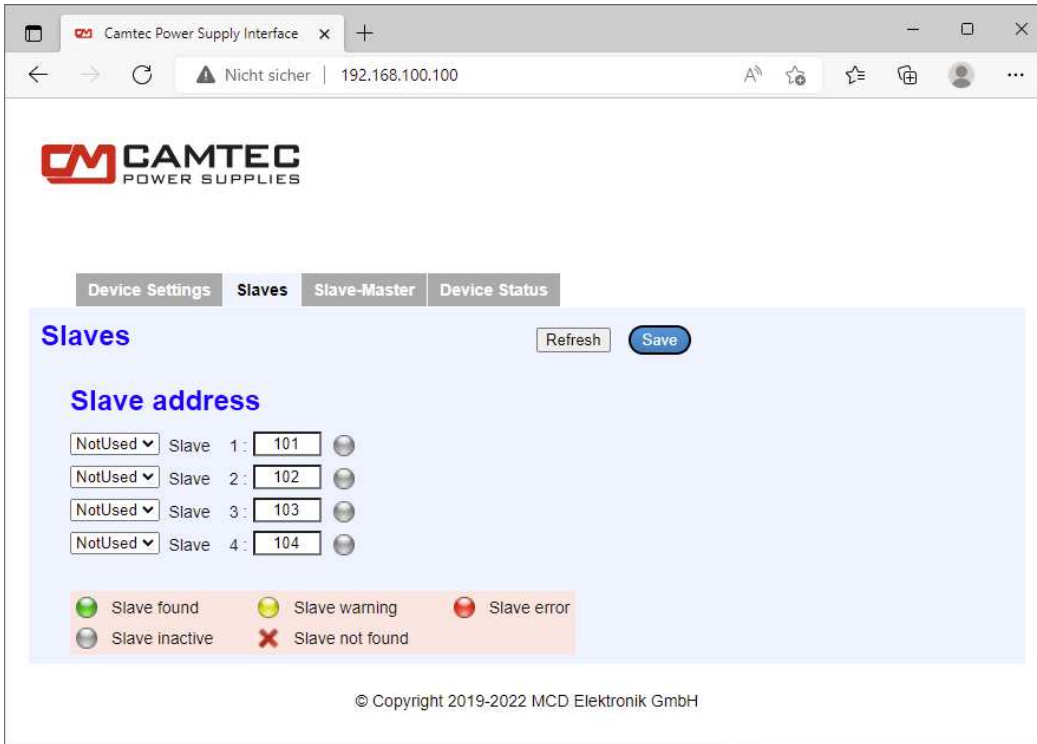

The above input mask shows only for devices being configured as a Master, Master-Master, or as a Slave-Master.

To access this window, type the valid IP address of the unit into your browser.

Slave address:	Slaves can be individually included or excluded from the defined network. (Used / Not Used). The address refers to the last IP octet of the Slaves. The other three octets of the Master and of the Slaves must be identical. The symbol behind the address shows whether a slave has been found or whether a warning or an error has occurred to the slave.
Refresh Button:	Press to update status
Save Button:	Press to save settings

1.4.3. Slaves-Master Table

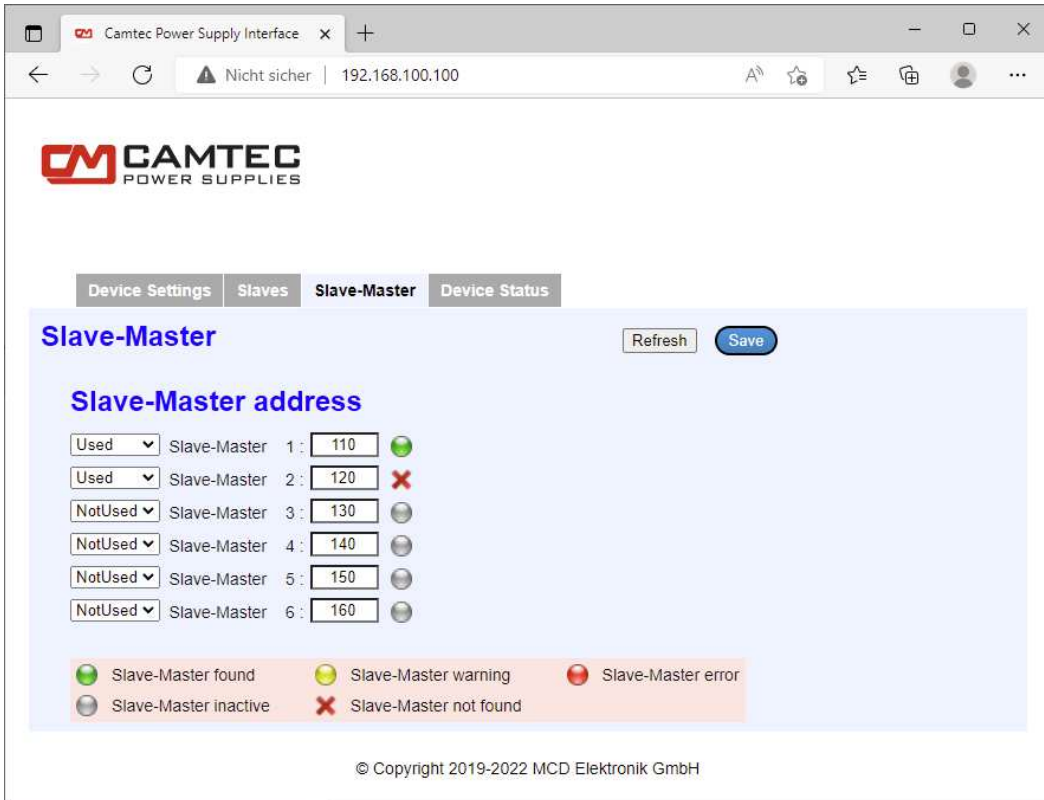

The above input mask shows only for devices configured as Master-Master.

To access this window, type the valid IP address of the unit into your browser.

Slave-Master address:	Slaves-Masters can be individually included or excluded from the defined network (Used / Not Used). The address refers to the last IP octet of the Slaves. The other three octets of the Master-Masters and of the Slave-Masters must be identical. The symbol behind the address shows whether the Slave-Master has been found or whether a warning or an error has occurred to the Slave-Master.
Refresh Button:	Press to update status
Save Button:	Press to save settings

1.4.4. Status and Voltage / Current setting

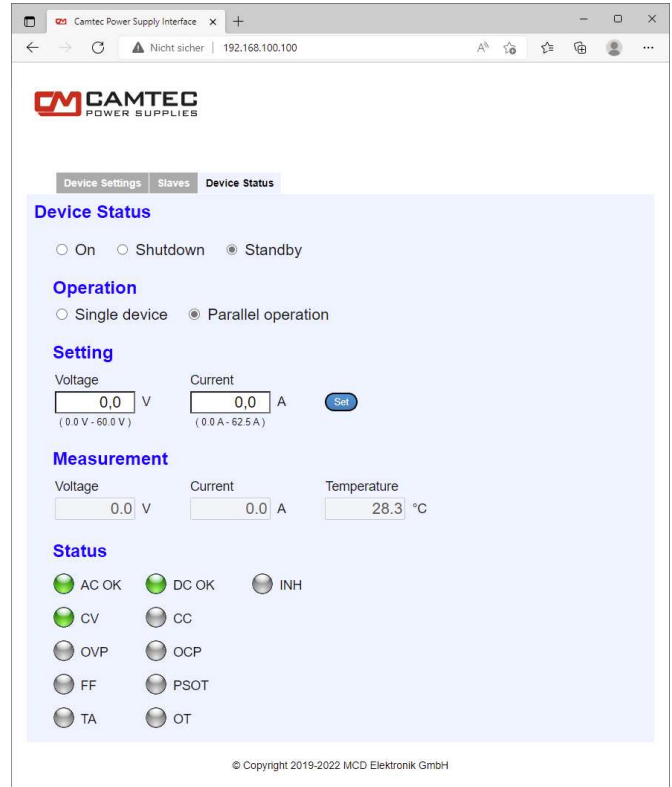
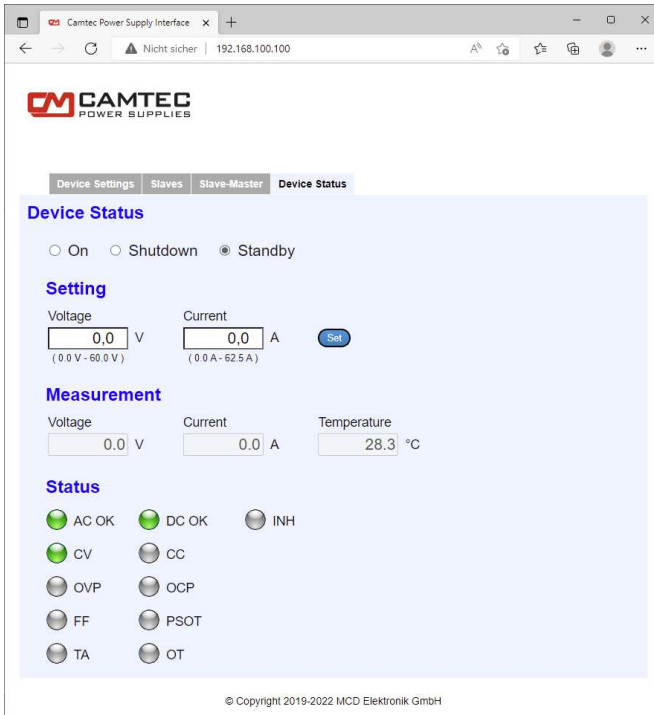

To access this window, type the valid IP address of the unit into your browser.

Device Status:	Shows the operational status of the power supply. When the device is defined as a Master or a Master-Master the values can be selected. When the power supply is defined as a Slave-Master or as a Slave no selection is accessible.
Operation:	Set to operate the power supply with slaves (parallel operation) or as independent device
Setting:	Here the output voltage and the current limiting can be set. The current setting is not featured for the CPS-EP models.
Measurement:	Monitors the real time output voltage and the current. The current voltage measuring, and the temperature measuring is not featured for the CPS-EP models.
Status:	Monitors operational status (synchronic LEDs of the device hardware). PSOT is not featured for the CPS-EX models. INH, CV, CC, OVP, OCP, PSOT, TA is not featured for the CPS-EP models.

2. CONTROL CONNECTIONS

2.1. CON1 (INH) Inhibit Connection (Interlock)

The power supply is equipped with an Inhibit/Interlock (INH) control input to lock the DC shutdown of the power supply.

For the nominal operation of the power supply, the “INH” connections must always remain short-circuited (inhibit is inactive). The power output is switched off as soon as the connection between the contacts of the INH input is opened (inhibit active). As soon the INH contacts are closed again, the power supply starts. Due to the soft start, the current and voltage increase continuously to the selected values within 100ms. A current of typically 2 mA flows between the INH contacts.

!WARNING! To prevent damage from incorrect connection assignment, never apply external voltage to the contacts of the INH. Never connect a resistor to the INH contacts. The control input INH may only be connected to a potential-free contact, such as a switch or a relay. Between the control input INH and the DC power output there is a reinforced insulation of 300Vdc and a basic insulation of 600Vdc working voltage.

If the cable length is longer than 3 m, shielded cables must be used and the shield must be connected to the M4 ground connection on the back of the power supply.

2.2. CON2 RJ45 (LAN) Ethernet Connection

The interface is used to control and configure the connected device. The integrated HTTP server can be reached via this interface. The communication between the master and the slaves is also implemented via this interface. The factory setting of the IP address is IP 192.168.100.100. When changing it to an individual IP address take into consideration that the address range is restricted (chapter 1.4.1). The maximum cable length is limited to 30m/98.5ft. Always use double shielded cable Cat 5e SF/UTP. Use an appropriate unmanaged ethernet switch with a minimum capability of 100 Mbit/s IEEE 802.3x standard.

For full performance and maximum speed other network devices that has nothing to do with the CPS power supplies network must not be connected to this switch. To avoid data flow slowing down do not connect the switch to the INTERNET.

2.3 CON3 CS-Bus (Current Share Bus CSB), Current Distribution in Parallel Mode

To prevent one of the power supplies from reaching the current limit too early in parallel operation and therefore displaying an error message, an even power distribution between the power supplies is desired. This prevents uneven loading and thus premature aging of the devices.

From CON3, connect the master's contact 2 (CS) to the slave's CON3 contact 2 (CS). Connect CON3 contact 1 (AGND) of the master to CON3 contact 1 (AGND) of the slaves. The power distribution between the devices is automatic. The current distribution accuracy is $\leq \pm 5\%$ when current is $I_{out} \geq 0.5 \times I_{out-max}$. Reduce the total output current by 5% to prevent overloading the device.

2.4. CON4 Sense Connection

2.4.1. Sense-Connection Single Unit Operation

The factory setting is local sensing. The sense wires are connected directly to the output.

When a load sensing is required connect the sense connections directly to the load

!WARNING! Avoid mixing up sense line polarization to prevent from damages to the power supply.

2.4.2. Sense-Connection in a Network Operation

Make sure that cable length and cross sections of all connected power supplies are equal to the busbar or the star point. Allow proper connection for proper resistance. Always connect the sense lines of all the paralleled power supplies to the busbar or to the star point.

!WARNING! Avoid mixing up sense line polarization to prevent from damages to the power supply.

3 HARDWARE INSTALLATION

3.1. Parallel installation of Master / Slave units for power increase.

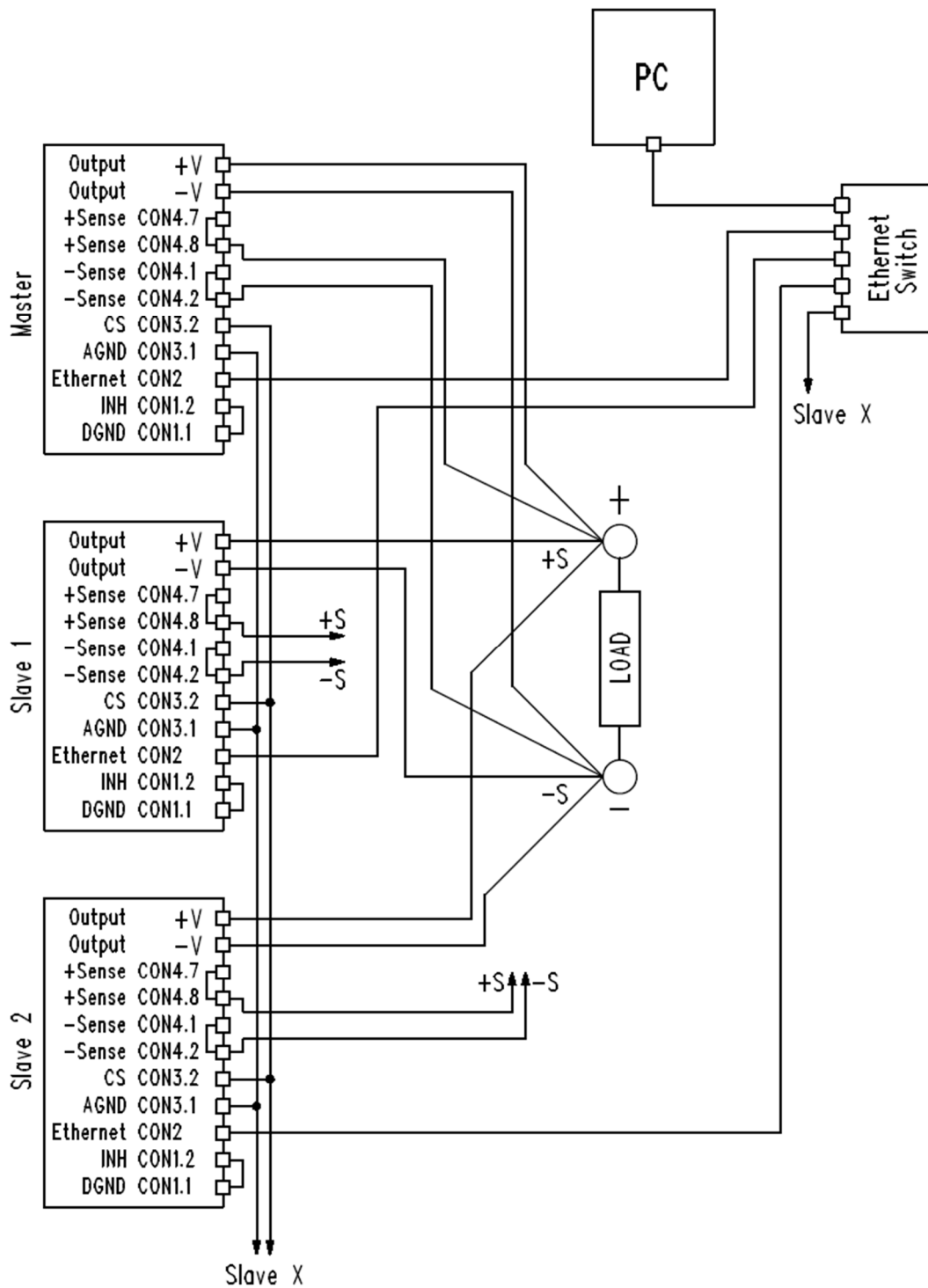

3.2. Parallel installation of Master-Master / Slave-Master / Slave units for power increase.

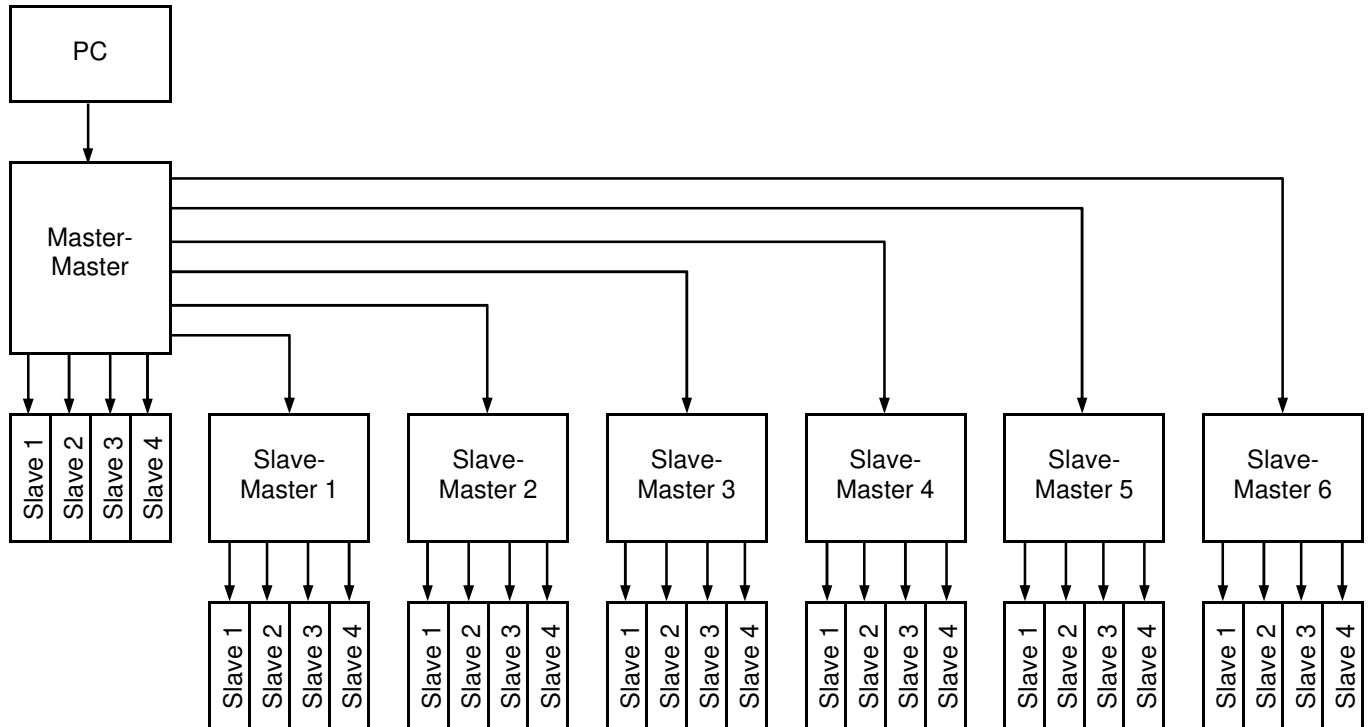

4 TECHNICAL DETAILS and LINE INSTALLATION

	Value	Description and Installation Requirements
RESOLUTION	12 Bit	
ISOLATION	300Vdc / 600Vdc	Ethernet, and the Inhibit connections have a reinforced isolation of max. 300Vdc and basic insulation of max. 600Vdc working voltage.
PORTS	CON1 INH 1x 2pole Pin-Header	Inhibit Connection; floating PIN1 = DGND PIN2 = INH Maximum cable length = 30m < 3m unshielded / > 3m shielded cable For a line length longer than 3m use shielded cables and connect the shield to the M4 Earth Connection at the back of the unit (see manual). The male connector jag is included. Male Connector Screws Torque 0,2-0,25 Nm. M4 Earth Connection Screw Torque 1,0-1,1Nm
	CON2 LAN (Ethernet) 1x RJ45 Cat 5e SF/UTP	Ethernet 100 Mbit/s IEEE 802.3x Control Operation and for Master / Slave – connection. Factory IP-Address: 192.168.100.100 IP Address Range: see chapter 1.4.1. Remote UDP-Port: 3000 (remote operation with computer) Remote TCP-Port: 5000 (alternative remote operation with computer) Slave-Master Control Port: 3001 (used for internal communication between the devices – please keep free) Slave Control Port: 3002 (used for internal communication between the devices – please keep free) Maximum cable length = 30m double shielded cable Cat 5e SF/UTP Use an appropriate unmanaged ethernet switch with at least 100 Mbit/s IEEE 802.3x capability. For full performance and maximum speed other network devices that has nothing to do with the CPS power supplies network must not be connected to the switch. To avoid data flow slowing down do not connect the switch to the INTERNET. Ethernet communication does not represent safety-critical communication, so system safety must not depend on functioning of communication.
	CON3 CS 1x 2pole Pin-Header	Current Share Bus CSB/CS Pin1: AGND Pin2: CS/CSB
	CON4 SENSE 1x 8pole Pin-Header	Sense connection (factory setting is local sensing) Pin1: Sense - Pin2: Sense - Pin3: nc Pin4: nc Pin5: nc Pin6: nc Pin7: Sense + Pin8: Sense + (nc = no connection / not in use)
CONTROLS	DIP-Switch Piano	See chapter 1.3.
	RESET button	See chapter 1.2

SETUP DEVICE	CPS-i2000/CPS-i3000	Set the 12-pole DIP-Switch on top of the power supply module as follows: S1-10 set to regulation mode 0-5V S11=1 CS disabled for single operation or CS-bus not used S11=0 CS enabled when current share parallel operation needed S12=1 Continuous Mode, enabled when parallel operation, ALWAYS!
	CPS-EX2000/CPS-EX3000	S11=1 CS disabled for single operation or CS-bus not used S11=0 CS enabled when current share parallel operation needed S12=1 Continuous Mode, enabled when parallel operation, ALWAYS!
	CPS-EP2000/CPS-EP3000	S11=1 CS disabled for single operation or CS-bus not used S11=0 CS enabled when current share parallel operation needed
EMC / EMI Power Supply LAN-Interface requirements	EMC directive requires	The enclosure of the power supply unit must be connected to the local reference ground with a short cable (1,5 - 2,5mm ² , max. 10 cm / 4 In.) The cable need to be connected to the M4 Earth Connection at the rear of the power supply (see figure below). M4 Earth Connection Screw Torque 1,0-1,1Nm
SENSE OPERATION	Single & Master-Slave operation	Maximum sense compensation per load lead: All output voltage models 2,0V Always allow proper connection for low contact resistance and ensure equal load line length

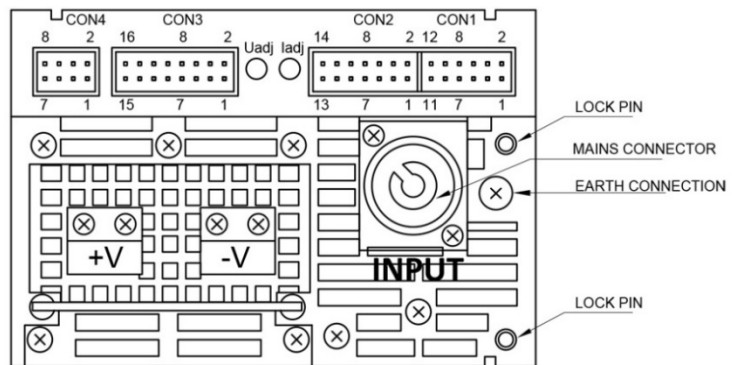

Notes:

- * The LOCK PIN is being used in a 19-inch sub rack only. It is being supplied together with the front plate kit for 3U or 2U racks.
- ** Connectors scope of supply:
DIGI3201 the MAINS, INHIBIT and the SENSE connector are scope of supply for each unit. The analogue interface comes with MAINS and CON 1-4 connectors. Additionally, find the article numbers of spare connectors at the end of the product manual.

Command LIST

A command is consisting of a text character sequence ending with an ASCII(13) character. All answers are also terminated with an ASCII(13) character. Parameters are separated from each other by semicolons. Commands – provided they do not return any values – are acknowledged with an 'ok'. Unrecognized or incorrectly parameterized commands are acknowledged with a '???'.

1. Command RV: RED VERSION

Reads a string of the software version of the device (firmware).

Command:

Command	Parameter	Details
RV		

Output:

Parameter	Details
Text	version

2. Command RIP: READ IP ADDRESS

Reads the IP address and the subnet mask.

Command:

Command	Parameter	Details
RIP		

Output:

Parameter	Details
xxx.xxx.xxx.xxx;xxx.xxx.xxx.xxx	IP-address; subnet mask

3. 3.1. Command SIP: SET IP ADDRESS

Sets the IP address and the subnet mask. Illegal address shows error.

Command:

Command	Parameter	Details
RIP	xxx.xxx.xxx.xxx;xxx.xxx.xxx.xxx	IP-address; subnet mask

Output:

Parameter	Details
ok	

3.2. Command RMAC: READ MAC-ADDRESS

Read MAC-address HEXA

Command:

Command	Parameter	Details
RMAC		

Output:

Parameter	Details
xx-xx-xx-xx-xx-xx	MAC-address

4. Command GDT: GET DEVICE TYPE

Reads the detected power supply model, e.g. „CPS-i3000.060“.

Command:

Command	Parameter	Details
GDT		

Output:

Parameter	Details
CPS-xxxxx.xxx	model name

5. Command GDN: GET DEVICE NAME

Reads the user defined name of the device

Command:

Command	Parameter	Details
GDN		

Output:

Parameter	Details
xxxxxxxxxxxx	text

6. Command GDF: GET DEVICE FUNCTION

Reads the device function that is set on the DIP-switch

Command:

Command	Parameter	Details
GDF		

Output:

Parameter	Details
xxxxxxxxxxxx	Possible Output: <ul style="list-style-type: none"> • MASTER-MASTER • SLAVE-MASTER • SLAVE • PARALLEL • SINGLE

7. Command SDF: SET DEVICE FUNCTION

Switches between single device and parallel operation. If the device has another function, this Command is not available.

Command:

Command	Parameter	Details
SDF	x	0 = single 1 = parallel

Output:

Parameter	Details
ok	

8. Command GSL: GET SLAVE LIST

Returns a list of slaves. This Command only works on devices with a configured master function.

Command:

Command	Parameter	Details
GSL		

Output:

Parameter	Details
x;x;xxx/x;x;xxx/x;x;xxx/x;x;xxx	list 4 Slaves: x: 0 / 1 = not used / used x: 0 / 1 = not connected / connected xxx: = last IP-octet

9. Command SSL: SET SLAVE

A slave in the list can be switched ON/OFF and its last IP octet can be set. If two identical active IP octets occur in the slave list and possibly the slave-master list, an error is returned. This Command only works on devices with a configured master function.

Command:

Command	Parameter	Details
SSL	x;x;xxx	x: 1 ... 4 = position in list x: 0 / 1 = not used / used xxx: = last IP-octet

Output:

Parameter	Details

10. Command GML: GENERATE SLAVE MASTER LIST

Returns a list of Slave-Masters. This Command only works on devices with a configured Master-Master function.

Command:

Command	Parameter	Details
GML		

Output:

Parameter	Details
x;x;xxx/x;x;xxx/x;x;xxx/x;x;xxx/x;x;xxx	list of 6 Slave-Master: x: 0 / 1 = not used / used x: 0 / 1 = not connected / connected xxx: = last IP-octet

11. Command SML: SLAVE-MASTER ON/OFF

A Slave Master in the list can be turned ON/OFF and its last IP octet can be set. If two identical active IP octets occur in the Slave-Master list and the Slave list, an error is returned. This Command only works on devices with a configured Master-Master function.

Command:

Command	Parameter	Details
SML	x;x;xxx	x: 1 ... 6 = position in list x: 0 / 1 = not used / used xxx: = last IP-octet

Output:

Parameter	Details

12. Command GO: GET OPERATION

Reads the operation stage of the device

Command:

Command	Parameter	Details
GO		

Output:

Parameter	Details
XX	ON = turned on SD = shutdown SB = standby

13. Command SO: SWITCH ON/OFF

Switches the power supply ON/OFF unless it is a slave master or slave. These are always controlled by the higher-level master.

Command:

Command	Parameter	Details
SO	XX	ON = turned on SD = shutdown SB = standby (when function available on the model)

Output:

Parameter	Details
ok	

14. Command GMS: GET MONITORS (Voltage & Current)

Reads the set voltage and the set current. Non-adjustable sizes will not be returned. The returned sizes depend on the power supply model.

Command:

Command	Parameter	Details
GMS		

Output:

Parameter	Details
x.xxxV;x.xxxA	monitor voltage and current

15. Command SV: SET VOLTAGE

Sets the output voltage. If the voltage cannot be adjusted (depending on the device type) or is outside the setting range, an error is returned.

Command:

Command	Parameter	Details
SV	x.x	Voltage in Volts. Decimal positions are separated by a point (not a comma).

Output:

Parameter	Details
ok	

16. Command SC: SET CURRENT

Sets the output current. If the current cannot be set (type-dependent) or is outside the setting range, an error is returned.

Command:

Command	Parameter	Details
SC	x.x	Current in Amperes. Decimal positions are separated by a point (not a comma).

Output:

Parameter	Details
ok	

17. Command GM: GET MEASURE (Monitors Analogue Measurements)

Depending on the model, reads back the measured values for voltage, current and temperature. Measured values are separated by semicolons and decimal places by periods. Measured values that are not available will not be returned.

Command:

Command	Parameter	Details
GM		

Output:

Parameter	Details
x.xxxV;x.xxxA;x.xC	Voltage [Volts], current [Amperes], temperature [°C] Celsius V = voltage A = current C = temperature

18. Command GS: GET SIGNALS

Depending on the model, reads back digital input signals. The signals are separated by semicolons. If none of the signals are present, an error message is output instead.

Command:

Command	Parameter	Details
GS		

Output:

Parameter	Details
AC_FAIL	If the mains voltage fails, no further signals are evaluated.
INH;DC_OK;CV;CC;OVP;OCP;FF;TA;OT;PSOT	If there is mains voltage, existing signals are listed.